

Flow Measurement

SITRANS F C

System information SITRANS F C Coriolis mass flowmeters

Overview



SITRANS F C Coriolis mass flowmeters are designed for measurement of a variety of liquids and gases. The meter is a multi-parameter device offering accurate measurement of mass flow, volume flow, density, temperature and fraction.

Transmitter	Page	Compact	Remote	Ex-Approval	Sensor	Page
MASS 6000 IP67 Polyamide enclosure	4/146	No	Yes	No	FCS200, DN 10 ... DN 25	4/168
		No	Yes	No	FC300, DN 4	4/177
		No	Yes	No	MASS 2100, DI 1.5	4/173
		Yes	Yes	No	MASS 2100, DI 3 ... DI 40	4/182
		No	Yes	No	MASS MC2, DN 50...DN 150	4/193
		No	Yes	Yes	MASS MC2 Ex, DN 50...DN 150	4/193
		No	Yes	No	MASS MC2 Hygienic, DN 20 ... DN 80	4/193
MASS 6000 19"	4/151	No	Yes	No	FCS200, DN 10 ... DN 25	4/168
		No	Yes	No	FC300, DN 4	4/177
		No	Yes	No	MASS 2100, DI 1.5	4/173
		No	Yes	No	MASS 2100, DI 3 ... DI 40	4/182
		No	Yes	No	MASS MC2, DN 50...DN 150	4/193
		No	Yes	Yes	MASS MC2 Ex, DN 50...DN 150	4/193
		No	Yes	No	MASS MC2 Hygienic, DN 20 ... DN 80	4/193
MASS 6000 Ex 19"	4/151	No	Yes	Yes	FCS200, DN 10 ... DN 25	4/168
		No	Yes	Yes	FC300, DN 4	4/177
		No	Yes	Yes	MASS 2100 Ex, DI 1.5	4/173
		No	Yes	Yes	MASS 2100 Ex, DI 3 ... DI 40	4/182
		No	Yes	No	MASS MC2, DN 50...DN 150	4/193
		No	Yes	No	MASS MC2 Hygienic, DN 20 ... DN 80	4/193
		MASS 6000 Ex d Stainless steel enclosure	4/158	No	Yes	Yes
No	Yes			Yes	FC300, DN 4	4/177
No	Yes			Yes	MASS 2100 Ex, DI 1.5	4/173
Yes	Yes			Yes	MASS 2100 Ex, DI 3 ... DI 40	4/182
No	Yes			No	MASS MC2, DN 50 ... DN 150	4/193
No	Yes			No	MASS MC2 Hygienic, DN 20 ... 80	4/193
SIFLOW FC070 Standard	4/164			No	Yes	No
SIFLOW FC070 CT	4/164	No	Yes	Yes	all except MC2	
		No	Yes	No	MC2	4/193

Benefits

Greater flexibility

- Wide product program
- Uniform sensor interface enabling "plug & play" for all transmitters
- Compact or remote installation using the same transmitters and sensors

Easier commissioning

All SITRANS F C Coriolis flowmeters feature a SENSORPROM memory unit which stores sensor calibration data and transmitter settings for the lifetime of the product.

At commissioning the flowmeter commences measurement without any initial programming.

The factory settings matching the sensor size are stored in the SENSORPROM unit. Also customer-specified settings are downloaded to the unit.

Easier service

- Comprehensive self-diagnosis and service menu enhances troubleshooting and meter verification.
- Transmitter replacement requires no programming. SENSORPROM automatically updates all settings after initialization.

Room for growth

USM II the Universal Signal Module with "plug & play" simplicity makes it easy to access and integrate the flowmeter with almost any system and bus-protocol and it ensures the flowmeter will be easy to upgrade to future communication/bus platforms.

Application

Coriolis mass flowmeters are suitable for measuring liquids and gases. The measurement is independent of changes in process conditions/parameters such as temperature, density, pressure, viscosity, conductivity and flow profile.

Due to this versatility the meter is easy to install. The Coriolis flowmeter is recognized for its high accuracy in a wide turn-down ratio.

The main applications of the Coriolis flowmeter can be found in all industries, such as:

Chemical and pharma	Detergents, bulk chemicals, pharmaceuticals, acids, alkalis
Food and beverage	Dairy products, beer, wine, soft-drinks, plato/brix, fruit juices and pulps, bottling, CO ₂ dosing, CIP-liquids
Automotive	Fuel injection nozzle and pump testing, filling of AC units, engine consumption, paint robots
Oil and gas	Filling of gas bottles, furnace control, CNG-dispensers, test separators, LPG
Water and waste water	Dosing of chemicals for water treatment

Flow Measurement

SITRANS F C

System information SITRANS F C Coriolis mass flowmeters

Please see Product selector
www.pia-selector.automation.siemens.com on the Internet, since some constraints might be related to some of the features



MASS 2100 DI 1.5	MASS 2100 DI 3 to DI 40	FC300 DN 4	MC2 DN 50 to DN 150	MC2 Hygienic DN 25 to DN 80	FCS200 DN 10 to DN 25	MASS 6000 IP67	MASS 6000 19"	MASS 6000 Ex d	SIFLOW FC070 Std/Ex CT
7ME4100	7ME4100, 7ME4200, 7ME4210	7ME4400	7ME4300	7ME4310	7ME4500	7ME4110	7ME4110	7ME4110	7ME4120

Design									
Compact		●				●		●	
Remote	●	●	●	●	●	●	●	●	●
Transmitter enclosure									
Polyamide, IP67/NEMA 4X						●			
Noryl (SIMATIC S7-300), IP20/NEMA 2									●
Stainless steel IP67/NEMA 4X								●	
19" rack IP20/NEMA 2 aluminum							●		
Back of panel IP20/NEMA 2 aluminum							●		
Wall mounting IP66/NEMA 4 ABS plastic							●		
Front of panel IP66/NEMA 4 ABS plastic							●		
Communication									
HART						●	●	●	
PROFIBUS PA						●	●	●	
PROFIBUS DP						●	●		
MODBUS RTU/RS485						●	●		●
MODBUS RTU/RS232									●
FOUNDATION Fieldbus H1						●	●	●	
DeviceNet						●	●		
Supply voltage									
24 V DC									●
24 V AC/DC						●	●	●	
115/230 V AC						●	●		
Pipe size									
DI 1.5 (1/16")	●								
DI 3 (1/8")		●							
DN 4 (1/6")			●						
DI 6 (1/4")		●							
DN 10 (3/8")					●				
DI 15 (1/2")		●							
DN 15 (1/2")					●				
DN 20 (3/4")				●					
DI 25 (1")		●							
DN 25 (1")				●	●				
DI 40 (1 1/2")		●							
DN 40 (1 1/2")				●					
DN 50 (2")			●	●					
DN 65 (2 1/2")			●	●					
DN 80 (3")			●	●					
DN 100 (4")			●						
DN 150 (6")			●						
Process connection norms and pressure									
Pipe thread									
NPT ANSI/ASME B.20.1; PN 100	●	●	●						
NPT ANSI/ASME B.20.1; PN 350					●				
VCO					●				
ISO 228/1; PN 100	●	●	●						

● = available

Flow Measurement

SITRANS F C

System information SITRANS F C
Coriolis mass flowmeters

Please see Product selector
www.pia-selector.automation.siemens.com on the Internet, since some constraints might be related to some of the features



	MASS 2100 DI 1.5	MASS 2100 DI 3 to DI 40	FC300 DN 4	MC2 DN 50 to DN 150	MC2 Hygienic DN 25 to DN 80	FCS200 DN 10 to DN 25	MASS 6000 IP67	MASS 6000 19"	MASS 6000 Ex d	SIFLOW FC070 Std/Ex CT
	7ME4100	7ME4100, 7ME4200, 7ME4210	7ME4400	7ME4300	7ME4310	7ME4500	7ME4110	7ME4110	7ME4110	7ME4120
Flange										
EN 1092-1 PN 40		●		●						
EN 1092-1 PN 100		●		● ¹⁾						
ANSI B16.5 Class 150		●		●						
ANSI B16.5 Class 300				●						
ANSI B16.5 Class 600		●		● ¹⁾						
Dairy										
DIN 11851 PN 25		●		● ¹⁾	●					
DIN 11851 PN 40		●								
DIN 11864-2A					●					
Clamp ISO 2852 PN 16		●								
ISO 2853 PN 16		●								
DIN 32676 Tri-Clamp PN 10/PN 16				●	●					
Others on request	●	●	●	●	●					
Pipe material										
Stainless steel AISI 316L/1.4435	●	●	●		●					
Stainless steel AISI 316Ti/1.4571				●						
Hastelloy C22/2.4602	●	● ⁵⁾	●			● ⁷⁾				
Hastelloy C4/2.4610				●						
With heating jacket										
Internal U - tube		●								
Pressure rating										
PN 40		●		●	●					
PN 100	●	●	●	● ²⁾						
PN 214						●				
PN 350						●				
High-pressure version ³⁾	●	●	●							
Accuracy										
Flow error ≤ 0.1 % of rate	●	●	●	●	●					
Flow error ≤ 0.15 % of rate				●	●					
Flow error ≤ 0.5 % of rate				●	●	●				
Density error ≤ 0.0005 g/cm ³		●								
Density error ≤ 0.001 g/cm ³	●			●	●					
Density error ≤ 0.0015 g/cm ³		● ⁴⁾	●							
Cable glands										
PG 13.5								● ⁶⁾		
½" NPT							●			
M20				●	●		●		●	

● = available

¹⁾ Not available for DN 150 sensor.

²⁾ Not available for DN 100 and DN 150 sensors.

³⁾ Please see technical specifications.

⁴⁾ DI 3 and DI 6

⁵⁾ DI 40 is not available for Hastelloy C22/2.4602.

⁶⁾ Only when mounted in enclosure.

⁷⁾ Process connectors in AISI 316Ti/1.4571

Flow Measurement

SITRANS F C

System information SITRANS F C Coriolis mass flowmeters

Please see Product selector
www.pia-selector.automation.siemens.com on the Internet, since some constraints might be related to some of the features



MASS 2100 DI 1.5	MASS 2100 DI 3 to DI 40	FC300 DN 4	MC2 DN 50 to DN 150	MC2 Hygienic DN 25 to DN 80	FCS200 DN 10 to DN 25	MASS 6000 IP67	MASS 6000 19"	MASS 6000 Ex d	SIFLOW FC070 Std/Ex CT
7ME4100	7ME4100, 7ME4200, 7ME4210	7ME4400	7ME4300	7ME4310	7ME4500	7ME4110	7ME4110	7ME4110	7ME4120

Approvals

Harzardous locations

Ex II 1G EEx ia IIC T3 (T4) ... T6	ATEX	●	●						
Ex ia IIC T3/T4 ... T6	ATEX		●						
Ex II (1)G [EEx ia] IIC	ATEX						●		
Ex II 2G EEx d e [ia/ib] IIC T6	ATEX							●	
Ex II (1)G [Ex ia] IIC Ga Ex II 3G Ex nA IIC T4 Gc	ATEX								● ⁴⁾⁵⁾
Ex II 1/2 G EEx emd [ib] IIC T6	ATEX								● ¹⁰⁾
Ex II 2 G EEx emd [ib] IIC T6	ATEX			● ¹¹⁾	● ¹¹⁾				
Ex II 1/2G Ex ia IIC T5/T4	ATEX					●			
Ex ia IIC T5/T4	IECEX					●			
Ex nA [ia] IIC T4	IECEX								● ⁵⁾
Class I, Div. 2, Gr. A, B, C, D	FM								●
Class I, Div. 1, Gr. A, B, C, D Class I, Zone 0, Aex ia IIC T3 ... T6 Class I, Zone 0, Ex ia IIC T3 ... T6	C-UL	● ¹⁾	● ¹⁾						
Class I, Div. 1, Gr. A, B, C, D Class I, Zone 0, Ex ia IIC T3 ... T6	C-UL		●						
Class I, Div. 2, Gr. A, B, C, D Class I, Zone 2, Aex nC IIC T4 Class I, Zone 2, Ex nC [nL] IIC T4	C-UL					● ²⁾			
Class I, Div. 1 and 2, Gr. A, B, C, D Class 1, Zone 2 and Zone 0, Aex nC [ia] IIC T4 Class 1, Zone 2 and Zone 0, Ex nC [ia] IIC T4	C-UL						● ³⁾		
Ex nA [ia] IIC T4, Class I, Zone 2, Aex nA [ia] IIC T4	uCSA _{US}								● ⁵⁾

Ordinary locations

USL, CNL-Flowmeter	C-UL					● ²⁾			
USR, CNR-Flowmeter	C-UL						● ⁶⁾		
USR, CNR-Flowmeter	C-UL						● ⁷⁾		
USL, CNL-Flowmeter	C-UL						● ⁸⁾		

PED

Fluid group 1 Category II, Module H	PED Directive 97/23/EC		● ⁹⁾						
Module B1 + D 0/25 ... 100 bar, -80/200°C, DN 20 ... 150	PED Directive 97/23/EC			●	●				

CRN

Category F OF10769.5C	CRN	●	●	●					
-----------------------	-----	---	---	---	--	--	--	--	--

Pharma

EHEDG	TUM				●				
-------	-----	--	--	--	---	--	--	--	--

Note: Special conditions for safe use might be specified in certificates or operating instructions.

● = available

1) Sensor pressure max. 100 bar (1450 psi)

2) Only compact version

3) Can be placed in zone 2 if mounted in minimum IP65 cabinet.

4) Can be placed in zone 2 if mounted in minimum IP54 cabinet.

5) Only Ex version

6) 24 V; IP20

7) 115 ... 230 V; IP20

8) 115 ... 230 V; IP65

9) Only DI 25 and DI 40

10) For sizes < DN 40 only

11) For sizes ≥ DN 50 only

Function

The flow measuring principle is based on the Coriolis effect. The flowmeter consists of a sensor type MASS 2100/FC300 or MC2 and a transmitter MASS 6000/SIFLOW FC070.

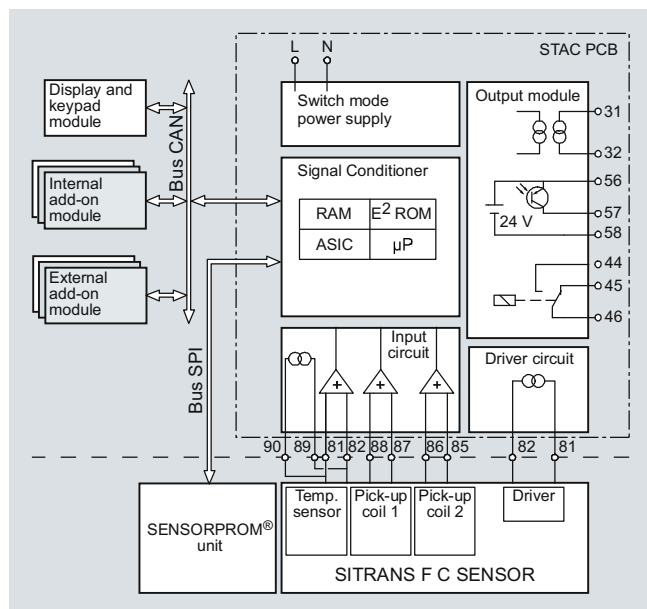

The SITRANS F C sensors are energized by an electro-mechanical driver circuit which oscillates the pipe at its resonant frequency.

Two pick-ups, 1 and 2 are placed symmetrically on both sides of the driver. When liquid or gas flows through the sensor, Coriolis force will act on the measuring pipe and cause a pipe deflection which can be measured as a phase shift on pick-up 1 and 2. The phase shift is proportional to the mass flow rate.

The amplitude of the driver is automatically regulated via a „phase locked loop“, to ensure a stable output from the 2 pick-ups in the region of 80 to 120 mV.

The temperature of the sensor is measured by a Pt1000, in a wheatstone configuration (4-wire). For MC2 the temperature is measured with a Pt100.

The flow-proportional signal from the 2 pick-ups, the temperature measurement and the driver frequency are fed into the SITRANS F C transmitter for calculations of mass, volume, fraction, temperature and density.

The analog to digital conversion takes place in an ultra-low noise ASIC with 23 bit signal resolution. The signal transfer function is based on a patented DFT technology (Discrete Fourier Transformation). The ASIC is constructed as a state machine gate array, which enables fast signal processing and filtering.

The ASIC has a built-in noise filter, which can be used to improve the meters' performance if the installation and application conditions are not ideal. Typically influence from process noise such as pump pulsations, mechanical vibrations, oscillating valves can be reduced considerably.

For communication purposes the SITRANS F C MASS 6000 transmitters have a CAN interface with a Siemens specific protocol. This concept is known as the USM II (Universal Signal Module) concept. The idea is that extra output modules or communication modules can be connected to this bus, making it possible to configure the flowmeter for the precise task in hand. When the internal CAN bus detects the installed module, it is automatically programmed to factory settings via the SENSORPROM memory unit, and the new menu is visible in the MASS 6000 display.

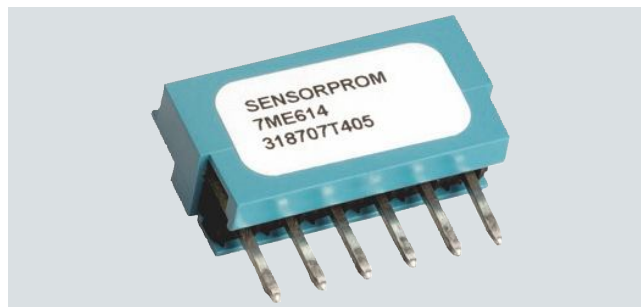

SENSORPROM flow memory unit

Currently the USM platform handles all present and future communication protocols, e.g., PROFIBUS DP, PROFIBUS PA, HART, MODBUS, FOUNDATION Fieldbus H1 and DeviceNet.

Integration

Installation of MASS 2100/FC300 and MC2 sensors

Installation requirements/System design information

The SITRANS F C mass flowmeter is suitable for in- and outdoor installations. The standard instrument meets the requirements of Protection Class IP67/NEMA 4X and IP66/NEMA 4. The flowmeter is bidirectional and can be installed in any orientation, however, the sensor is not self-emptying in all positions. It is important to ensure that the meter tubes are always completely filled with homogeneous fluid. Otherwise measuring errors may occur.

The corrosion resistance of the fluid-wetted materials must be evaluated.

The pressure drop through the sensor is a function of the properties of the fluid and the flow rate. The **Sizing Program** (download from <https://pia.khe.siemens.com/index.aspx?nr=11501>) can be used to calculate the pressure drop.

The following points are to be considered during installation:

The preferred flow direction is indicated by the arrow on the flowmeter. Flow in this direction will be indicated as positive.

Installation orientation

- MASS 2100/FC300 – sensors
The optimal installation orientation is horizontal.
- MC2 – sensors
The optimal installation orientation is vertical with the flow upwards.

Supports

- In order to support the weight of the flowmeter and to ensure reliable measurements when external effects exist (e.g. vibrations), the sensor should be installed in rigid pipelines. Two supports or hangers should be installed symmetrically and stress-free in close proximity to the process connections.

Shut-off devices

- To conduct a system zero adjustment, shut-off devices are required in the pipeline.
 - In horizontal installations at the outlet for FC300 and MC2 and the inlet for MASS 2100.
 - In vertical installations at the inlet.
- When possible, shut-off devices should be installed both up- and downstream of the flowmeter.

Flow Measurement

SITRANS F C

System information SITRANS F C Coriolis mass flowmeters

Installation: straight run requirements

- The mass flowmeter does not require any flow conditioning straight inlet sections. Care should be exercised to ensure that any valves, gates, sight glasses etc. do not cavitate and are not set into vibration by the flowmeter.

System design information

- The presence of gas bubbles in the fluid may result in erroneous measurements, particularly in the density measurement. Therefore the flowmeter should not be installed at the highest point in the system. Advantageous are installations in low pipeline sections, at the bottom of a U-section in the pipeline.
- Long drop lines downstream from the flowmeter should be avoided to prevent the meter tube from draining.
- The flowmeter should not come into contact with any other objects. Avoid attachments to the housing.
- When the cross-section of the connecting pipeline is larger than the sensor size, suitable standard reducers may be installed.
- If strong vibrations exist in the pipeline, they should be damped using elastic pipeline elements. The damping devices must be installed outside the supported flowmeter section and outside the section between the shut-off devices. The direct connection of flexible elements to the sensor should be avoided.
- Make sure that any dissolved gases, which are present in many liquids, do not outgas. The back pressure at the outlet should be at least 0.2 bar (3 psi).
- Assure that operation below the vapor pressure cannot occur when a vacuum exists in the meter tube or for fluids which boil readily.
- The sensor should not be installed in the vicinity of strong electromagnetic fields, e.g. near motors, pumps, transformers etc.
- When operating more than one meter in one or multiple interconnected pipelines, the sensors should be spaced distant from each other or the pipelines should be decoupled to prevent cross talk.

Zero adjustment

- In order to adjust the zero under operating conditions it must be possible to reduce the flow rate to „ZERO“ while the meter tube is completely filled. A bypass line is optimal when the process cannot be shut down. It is important for accurate measurements that during the zero adjustment there are no gas bubbles in the flowmeter. It is also important that the pressure and temperature in the meter tube be the same as that which exists during operation.

Technical specifications

Flowmeter uncertainty/specifications

To ensure continuous accurate measurement, flowmeters must be calibrated. The calibration is conducted at Siemens flow facilities accredited according to ISO/IEC 17025 by DANAK or UKAS.

The accreditation bodies DANAK and UKAS have signed the ILAC MRA agreement (International Laboratory Accreditation Corporation - Mutual Recognition Arrangement). Therefore the accreditation ensures international traceability and recognition of the test results in 39 countries worldwide, including the US (NIST traceability).

A calibration certificate is shipped with every sensor and calibration data are stored in the SENSORPROM memory unit.

MASS 2100 sensors and MASS 6000 transmitters

	5 %		50 %		100 %	
	kg/h	(lb/h)	kg/h	(lb/h)	kg/h	(lb/h)
DI 1.5 (1/16")	1	(2.2)	32.5	(71.6)	65	(140)
DI 3 (1/8")	12	(26)	125	(275)	250	(550)
DN 4 (1/6")	17.5	(38)	175	(386)	350	(770)
DI 6 (1/4")	50	(110)	500	(1 102)	1 000	(2 200)
DI 15 (1/2")	280	(617)	2 800	(6 173)	5 600	(12 345)
DI 25 (1")	1 250	(2 756)	12 500	(27 558)	25 000	(55 100)
DI 40 (1 1/2")	2 600	(5 732)	26 000	(57 320)	52 000	(114 600)

- Q_{max} is found at a pressure drop of 1 bar (29 psi). With increased counterpressure Q_{max} will increase.
- For flow > 5 % of the sensors max. flow rate, the error can be read directly from the curve.
- For flow < 5 % of the sensors max. flow rate, use the formula to calculate the error.
- The error curve is plotted from the formula:

$$E = \pm \sqrt{(0.10)^2 + \left(\frac{Z \times 100}{qm}\right)^2}$$

E = Error [%]
Z = Zero point error [kg/h]
qm = Mass flow [kg/h]

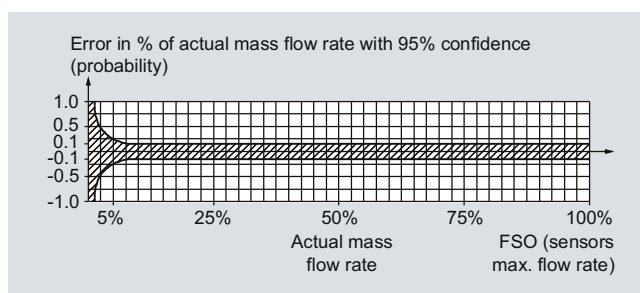

Reference conditions for MASS 2100 (ISO 9104 and DIN/EN 29104)

Flow conditions	Fully developed flow profile
Temperature, medium	20 °C ± 2 °C (68 °F ± 3.6 °F)
Temperature, ambient	20 °C ± 2 °C (68 °F ± 3.6 °F)
Liquid pressure	2 ± 1 bar
Density	0.997 g/cm ³
Brix	40 °Brix
Supply voltage	$U_n \pm 1\%$
Warming-up time	30 min.
Cable length	5 m between transmitter and sensor

Additions in the event of deviations from reference conditions

Current output	As pulse output ± (0.1% of actual flow + 0.05 % FSO)
Effect of ambient temperature	<ul style="list-style-type: none"> Display/frequency/pulse output: < ± 0.003%/K act. Current output: < ± 0.005 %/K act.
Effect of supply voltage	< 0.005 % of measuring value on 1 % alteration

Sensor type	FC300	MASS 2100					
Sensor size	DN 4 (1/6")	DI 1.5 (1/16")	DI 3 (1/8")	DI 6 (1/4")	DI 15 (1/2")	DI 25 (1")	DI 40 (1 1/2")
Number of measuring pipes	1	1	1	1	1	1	1
Mass flow							
Linearity error	% of rate	0.10	0.10	0.10	0.10	0.10	0.10
Repeatability error	% of rate	0.05	0.05	0.05	0.05	0.05	0.05
Max. zero point error	[kg/h]	0.010	0.001	0.010	0.050	0.200	1.500
Density							
Density error ¹⁾	[g/cm ³]	0.0015	0.001	0.0015	0.0015	0.0005	0.0005
Repeatability error	[g/cm ³]	0.0002	0.0002	0.0002	0.0002	0.0001	0.0001
Range	[g/cm ³]	0 ... 2.9	0 ... 2.9	0 ... 2.9	0 ... 2.9	0 ... 2.9	0 ... 2.9
Temperature							
Error	[°C (°F)]	0.5 (0.9)	0.5 (0.9)	0.5 (0.9)	0.5 (0.9)	0.5 (0.9)	0.5 (0.9)
Brix							
Error	[°Brix]	0.3	0.2	0.3	0.3	0.1	0.1

¹⁾ Accuracy is only valid when sensor is density-calibrated.

Sensor type	MC2				
Sensor size (standard version)	DN 50 (2")	DN 65 (2 1/2")	DN 80 (3")	DN 100 (4")	DN 150 (6")
Sensor size (hygienic version)	DN 20 (3/4") DN 25 (1") DN 40 (1 1/2") DN 50 (2")	DN 65 (2 1/2")	DN 80 (3")		
Number of measuring pipes	2	2	2	2	2
Mass flow:					
Linearity error	% of rate	0.15	0.15	0.15	0.15
Reproducibility of flowrate at rates > 5 % of Q _{max}	% of rate	0.1	0.1	0.1	0.1
Max. zero point error	[kg/h (lb/h)]	DN 20 0.6 (1.32), DN 25 0.96 (2.12), DN 40 2.85 (6.28), DN 50 5.52 (12.17)	11.34 (25.00)	14.76 (32.54)	24.96 (55.03)
Density					
Density error	(Standard) [g/cm ³]	0.005	0.005	0.005	0.005
	(Extended) [g/cm ³]	0.001	0.001	0.001	Not available
Range	[kg/dm ³]	0.5 ... 3.5	0.5 ... 3.5	0.5 ... 3.5	0.5 ... 3.5
Repeatability error	[g/l]	± 0.1	± 0.1	± 0.1	± 0.1
Temperature					
Error	[°C (°F)]	1.0 (1.8)	1.0 (1.8)	1.0 (1.8)	1.0 (1.8)
Brix²⁾					
Error	[°Brix]	0.25	0.25	0.25	0.25
					Not available

²⁾ Flow and density calibration (1 kg/m³) required.

Flow Measurement

SITRANS F C

System information SITRANS F C Coriolis mass flowmeters

Flowmeter uncertainty/specifications

MC2 sensors and MASS 6000 transmitters

	5 %		50 %		100 %	
	kg/h	(lb/h)	kg/h	(lb/h)	kg/h	(lb/h)
DN 20 (¾")	230	(507)	2 300	(5 071)	4 600	(10 141)
DN 25 (1")	368	(811)	3 680	(8 113)	7 360	(16 226)
DN 40 (1½")	1 093	(2 409)	10 925	(24 085)	21 850	(48 171)
DN 50 (2")	2 130	(4 695)	21 300	(46 958)	42 600	(93 900)
DN 65 (2½")	4 350	(9 590)	43 500	(95 900)	87 000	(191 800)
DN 80 (3")	5 670	(12 500)	56 700	(125 002)	113 400	(250 000)
DN 100 (4")	9 600	(21 164)	96 000	(211 643)	192 000	(423 300)
DN 150 (6")	25 500	(56 217)	255 000	(562 178)	510 000	(1 124 356)

Flow capacity calculated at 1 bar pressure loss on water at 20 °C.

$$E = \pm \sqrt{(0.15)^2 + \left(\frac{z \times 100}{qm}\right)^2}$$

E = Error [%]

Z = Zero point error [kg/h]

qm = Mass flow [kg/h]

Q_{max.} at 2 bar pressure loss at 1 g/cm³

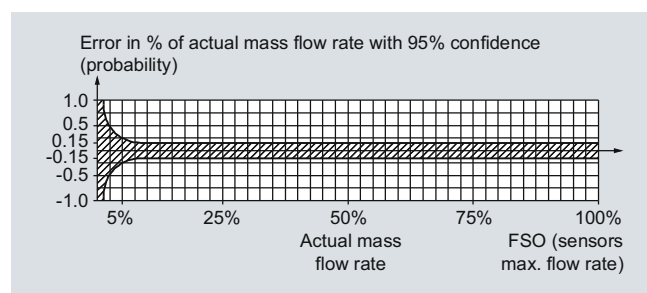

Technical specifications PROFIBUS PA/DP

General specifications

PROFIBUS device profile	3.00 Class B
Certified	Yes, according to Profile for process control devices V3.00.
MS0 connections	1
MS1 connections	1
MS2 connections	2

Electrical specification DP

Physical layer specifications

Applicable standard	EN 50170 vol. 2
Physical Layer (Transmission technology)	RS485
Transmission speed	≤ 1.5 Mbit/s
Number of stations	Up to 32 per line segment, (maximum total of 126)

Cable specification (Type A)

Cable design	Two wire twisted pair
Shielding	CU shielding braid or shielding braid and shielding foil
Impedance	35 up to 165 Ω at frequencies from 3 ... 20 MHz
Cable capacity	< 30 pF per meter
Core diameter	> 0.34 mm ² , corresponds to AWG 22
Resistance	< 110 Ω per km
Signal attenuation	Max. 9 dB over total length of line section
Max. bus length	200 m at 1500 kbit/s, up to 1.2 km at 93.75 kbit/s. Extendable by repeaters

Electrical specification PA

Physical layer specifications

Applicable standard	EN 50170
Physical Layer (Transmission technology)	IEC-61158-2
Transmission speed	31.25 kbit/s
Number of stations	Up to 32 per line segment, maximum total of 126)
Max. basic current [I _B]	14 mA
Fault current [I _{FDE}]	0 mA
Bus voltage	9 ... 32 V (non Ex)

Preferred cable specification (Type A)

Cable design	Two wire twisted pair
Conductor area (nominal)	0.8 mm ² (AWG 18)
Loop resistance	44 Ω/km
Impedance	100 Ω ± 20 %
Wave attenuation at 39 kHz	3 dB/km
Capacitive asymmetry	2 nF/km
Bus termination	Passive line termination at both
Max. bus length	Up to 1.9 km. Extendable by repeaters

IS (Intrinsic Safety) data

Required sensor electronics	Compact mounted SITRANS F C MASS 6000 Ex d
FISCO	Yes
Max. U _I	17.5 V
Max. I _I	380 mA
Max. P _I	5.32 V
Max. L _I	10 μH
Max. C _I	5 nF
Max. U _O	1.3 V
Max. I _O	50 μA

FISCO cable requirements

Loop resistance R _C	15 ... 150 Ω/km
Loop inductance L _C	0.4 ... 1 mH/km
Capacitance C _C	80 ... 200 nF/km
Max. Spur length in IIC and IIB	30 m
Max. Trunk length in IIC	1 km
Max. Trunk length in IIB	5 km

PROFIBUS parameter support

The following parameters are accessible using a MS0 relationship from a Class 1 Master. MS0 specifies cyclic Data Exchange between a Master and a Slave.

Cyclic services:

Input (Master view)	Parameter	MASS 6000
	Mass flow	✓
	Volume flow	✓
	Temperature	✓
	Density	✓
	Fraction A ¹⁾	✓
	Fraction B ¹⁾	✓
	Pct Fraction A ¹⁾	✓
	Totalizer 1	✓
	Totalizer 2 ²⁾	✓
	Batch progress ²⁾	✓
	Batch setpoint	✓
	Batch compensation	✓
	Batch status (running ...)	✓
Output (Master view)	Set Totalizer 1+2	✓
	Set Mode Totalizer 1+2	✓
	Batch control (start, stop ...)	✓
	Batch setpoint	✓
	Batch compensation	✓

¹⁾ Requires a SENSORPROM containing valid fraction data.

²⁾ Value returned is dependent on the BATCH function.

When ON, Batch progress is returned.

When OFF, TOTALIZER 2 is returned.

Flow Measurement

SITRANS F C

Transmitter MASS 6000 IP67 compact/remote

Overview



MASS 6000 is based on the latest developments within digital signal processing technology – engineered for high performance, fast flow step response, fast batching applications, high immunity against process noise, easy to install, commission and maintain.

The MASS 6000 transmitter delivers true multiparameter measurements i.e. mass flow, volume flow, density, temperature and fraction.

The MASS 6000 IP67 transmitter can be compact mounted on all sensors of type MASS 2100 DI 3 to DI 40, and can be used in remote version for all types of MASS 2100/MC2 and FC300 sensors.

Benefits

- Dedicated mass flow chip with the latest ASIC technology
- Fast batching and flow step response with an update rate of true 30 Hz
- Superior noise immunity due to a patented DFT (Discrete Fourier Transformation) algorithm.
- Front end resolution better than 0.35 ns improves zero point stability and enhances dynamic turn-down ratio on flow and density accuracy.
- Advanced diagnosis and service menu enhances troubleshooting and meter verification.
- Built-in batch controller with compensation and monitoring comprising 2 built-in totalizers
- Multi-parameter outputs, individual configurable for mass flow, volume flow, density, temperature or fraction flow such as BRIX or PLATO
- Digital input for batch control, remote zero adjust or forced output mode
- All outputs can be forced to preset value for simulation, verification or calibration purposes.
- User-configurable operation menu with password protection
 - 3 lines, 20 characters display in 11 languages
 - Self-explaining error handling/log in text format
 - Keypad can be used for controlling batch as start/stop/hold/reset
- SENSORPROM technology automatically configures transmitter at start-up providing:
 - Factory pre-programming with calibration data, pipe size, sensor type, output settings
 - Any values or settings changed by users are stored automatically
 - Automatically re-programming any new transmitter without loss of accuracy
 - Transmitter replacement in less than 5 minutes.
 - True "plug & play"

- 4-wire Pt1000 temperature measurement ensures optimum accuracy on mass flow, density and fraction flow.
- Fraction flow computation based on a 5th-order algorithm matching all applications.
- USM II platform enables fitting of add-on bus modules without loss of functionality.
 - All modules can be fitted through true "plug & play"
 - Module and transmitter are automatically configured through the SENSORPROM.
- Installation of the transmitter to the sensor is simple "plug & play" via the sensor pedestal.

Application

SITRANS F C mass flowmeters are suitable for all applications within the entire process industry, where there is a demand for accurate flow measurement. The meter is capable of measuring both liquid and gas flow.

The main applications for the MASS 6000 IP67 transmitter can be found in:

- Food and beverage industries
- Pharmaceutical industries
- Automotive industry
- Oil and gas industry
- Power generation and utility industry
- Water and waste water industry

Design

The transmitter is designed in an IP67/NEMA 4X compact polyamide enclosure which can be compact mounted on the MASS 2100 sensor range DI 3 to DI 40 (1/8" to 1½") and remote mounted for the entire sensor series.

The MASS 6000 IP67 is available as standard with 1 current, 1 frequency/pulse and 1 relay output and can be fitted with add-on modules for bus communication.

Function

The following functions are available:

- Mass flow rate, volume flow rate, density, temperature, fraction flow
- 1 current output, 1 frequency/pulse output, 1 relay output, 1 digital input
- All outputs can be individually configured with mass, volume, density etc.
- 2 built-in totalizers which can count positive, negative or net
- Low flow cut-off
- Density cut-off or empty pipe cut-off, adjustable
- Flow direction adjustable
- Error system consisting of error-log, error pending menu
- Display of operating time
- Uni/bidirectional flow measurement
- Limit switches with 1 or 2 limits, programmable for flow, density or temperature
- Noise filter setting for optimization of measurement performance under non-ideal application conditions
- Full batch controller
- Automatic zero adjustment menu, with zero point evaluation feed back
- Full service menu for effective and straight forward application and meter troubleshooting

Technical specifications

Measurement of	Mass flow [kg/s (lbs/min)], volume flow [l/s (gpm)], fraction [%], °Brix, density [kg/m ³ , (lbs/ft ³)], temperature [°C (°F)]
Current output	
Current	0 ... 20 mA or 4 ... 20 mA
Load	< 800 Ω
Time constant	0 ... 99.9 s adjustable
Digital output	
Frequency	0 ... 10 kHz, 50 % duty cycle
Time constant	0 ... 99.9 s adjustable
Active	24 V DC, 30 mA, 1 KΩ ≤ R _{load} ≤ 10 KΩ, short-circuit-protected
Passive	3 ... 30 V DC, max. 110 mA, 1 KΩ ≤ R _{load} ≤ 10 KΩ
Relay	
Type	Change-over relay
Load	42 V/2 A peak
Functions	Error level, error number, limit, flow direction
Digital input	
Functionality	11 ... 30 V DC (R _i = 13.6 kΩ) Start/hold/continue batch, zero point adjust, reset totalizer 1/2, force output, freeze output
Galvanic isolation	All inputs and outputs are galva- nically isolated, isolation voltage 500 V.
Cut-off	
Low-flow	0 ... 9.9 % of maximum flow
Limit function	Mass flow, volume flow, fraction, density, sensor temperature
Totalizer	Two eight-digit counters for for- ward, net or reverse flow
Display	<ul style="list-style-type: none"> Background illumination with al- phanumerical text, 3 × 20 char- acters to indicate flow rate, totalized values, settings and faults. Time constant as current output 1 Reverse flow indicated by nega- tive sign
Zero point adjustment	Via keypad or remote via digital input
Ambient temperature	
Operation	-20 ... +50 °C (-4 ... +122 °F), max. rel. humidity 80 % at 31 °C (87.8 °F) decreasing to 50 % at 40 °C (104 °F) according to IEC/EN/UL 61010-1
Storage	-40 ... +70 °C (-40 ... +158 °F) (Humidity max. 95 %)
Communication	Add-on modules: HART, PROFIBUS PA and DP, MODBUS RTU RS485, DeviceNet, FOUNDATION Fieldbus H1

Enclosure

Material	Fibre glass reinforced polyamide
Rating	IP67/NEMA 4X to IEC 529 and DIN 40050 (1 mH ₂ O for 30 min.)
Mechanical load	18 ... 1000 Hz random, 3.17 Grms, in all directions, to IEC 68-2-36

Supply voltage

24 V version	
• Supply	24 V DC/AC, 50 ... 60 Hz
• Fluctuation	18 ... 30 V DC 20 ... 30 V AC
• Power consumption	10 W
230 V version	
• Supply	87 ... 253 V AC, 50 ... 60 Hz
• Power consumption	26 VA
Fuse	
• 230 V version	T 400 mA, T 250 V (IEC 127) - not replaceable by operator
• 24 V version	T 1 A, T 250 V (IEC 127) - not replaceable by operator

EMC performance

Emission	EN/IEC 61000-6-4 (Industry)
Immunity	EN/IEC 61000-6-2 (Industry)

NAMUR

Within the value limits according
to "General requirements" with
error criteria A in accordance with
NE 21

Environment

Environmental conditions acc. to IEC/EN/UL 61010-1:	<ul style="list-style-type: none"> Altitude up to 2000 m POLLUTION DEGREE 2
--	---

Maintenance

The flowmeter has a built-in error
log/pending menu which should
be inspected on a regular basis.

Cable glands

Two types of cable gland are
available in polyamide in the fol-
lowing dimensions:
M20 or ½" NPT

Flow Measurement

SITRANS F C

Transmitter MASS 6000 IP67 compact/remote

Selection and Ordering data	Order No.
SITRANS F C MASS 6000 transmitter Transmitter for wall mounting with wall mounting bracket, fibre glass reinforced polyamide (1 current output, 1 frq./pulse output, 1 relay output and connection board/PCB)	7 ME 4 1 1 0 - AA 0 - A
Version Remote IP67/NEMA 4X enclosure	2
Supply voltage 115/230 V AC, 50 ... 60 Hz 24 V AC/DC	1 2
Display/Keypad with display	1
Serial communication No communication HART PROFIBUS PA Profile 3 PROFIBUS DP Profile 3 MODBUS RTU RS485 DeviceNet FOUNDATION Fieldbus H1	A B F G E H J
Cable glands M20 ½" NPT	1 2

Please also see www.siemens.com/SITRANSOrdering for practical examples of ordering

Operating instructions for SITRANS F C MASS 6000 IP67

Description	Order No.
• English	A5E03071936

This device is shipped with a Quick Start guide and a CD containing further SITRANS F C literature.

All literature is also available for free at:
<http://www.siemens.com/flowdocumentation>

Accessories

Description	Order No.
Cable glands, screwed entries type in polyamide (100 °C (212 °F)) black, 2 pcs. • M20 • ½" NPT	A5E00822490 A5E00822501
Sun lid for MASS 6000 transmitter (Frame and lid)	A5E02328485

Note: The operating instructions should be ordered as a separate line on the order.

Add-on module

Description	Order No.
HART (Ex-i)	FDK-085U0226
PROFIBUS PA Profile 3 (Ex-i)	FDK-085U0236
PROFIBUS DP Profile 3	FDK-085U0237
MODBUS RTU RS485	FDK-085U0234
FOUNDATION Fieldbus H1 (Ex-i)	A5E02054250
DeviceNet	FDK-085U0229



Operating instructions for SITRANS F add-on modules

Description	Order No.
HART • English	A5E03089708
PROFIBUS PA/DP • English • German	A5E00726137 A5E01026429
MODBUS • English • German • Spanish • French	A5E00753974 A5E03089262 A5E03089278 A5E03089265
FOUNDATION Fieldbus • English • German • Spanish • French	A5E02318728 A5E02488856 A5E02512177 A5E02512169
DeviceNet • English	A5E03089720

This device is shipped with a Quick Start guide and a CD containing further SITRANS F C literature.

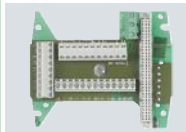

Spare parts for compact or remote IP67 version

Description	Order No.
MASS 6000 transmitter IP67/NEMA 4X Fibre glass reinforced polyamide and without connection board 1 current output 1 frq./pulse output 1 relay output • 115/230 V AC, 50/60 Hz • 24 V AC/DC	7ME4110-1AA10-1AA0 7ME4110-1AA20-1AA0
Wall mounting unit for IP67/NEMA 4X version with wall bracket, without connection board but with • 4 x M20 cable glands • 4 x ½" NPT cable glands	FDK-085U1018 A5E01164211
Connection board/PCB Supply voltage: 115/230 V/24 V AC/DC	FDK-083H4260



Flow Measurement SITRANS F C

Transmitter MASS 6000 IP67 compact/remote

Description	Order No.	
Terminal box kit with <ul style="list-style-type: none"> M20 cable glands ½" NPT cable glands <p>Change from remote to compact mounting of MASS 6000 IP67/NEMA 4X with MASS 2100. The kit consists of a terminal box in polyamide incl. connection board, cable and connector between PCB and sensor pedestal, PCB, seal and screws (4 pcs.) for mounting on sensor</p>	A5E00832338 A5E00832342	
Terminal box with <ul style="list-style-type: none"> M20 cable glands ½" NPT cable glands 	FDK-085U1050 A5E01164206	
Terminal box – lid in polyamide	FDK-085U1003	
Display and keypad <ul style="list-style-type: none"> Siemens Front 	FDK-085U1039	

Dimensional drawings

Compact

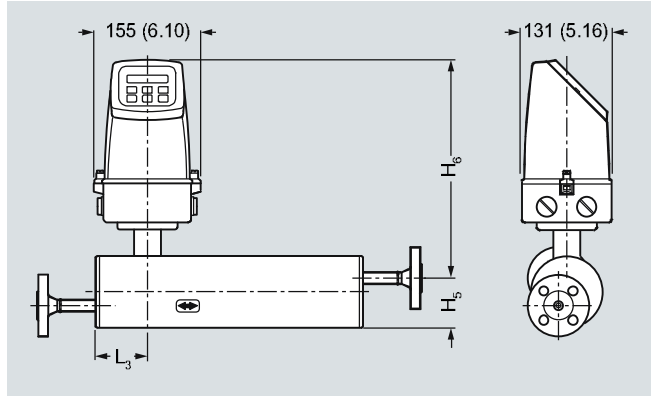

Dimensions in mm (inch)

MASS 2100

Sensor size [Di (inch)]	L ₃ [mm (inch)]	H ₅ [mm (inch)]	H ₆ [mm (inch)]	H ₅ + H ₆ [mm (inch)]
3 (1/8)	75 (2.95)	82 (3.23)	306 (12.04)	388 (15.28)
6 (¼)	62 (2.44)	72 (2.83)	316 (12.44)	388 (15.28)
15 (½)	75 (2.95)	87 (3.43)	326 (12.83)	413 (16.26)
25 (1)	75 (2.95)	173 (6.81)	330 (13.00)	503 (19.80)
40 (1½)	75 (2.95)	227 (8.94)	330 (13.00)	557 (21.93)

Transmitter wall mounted

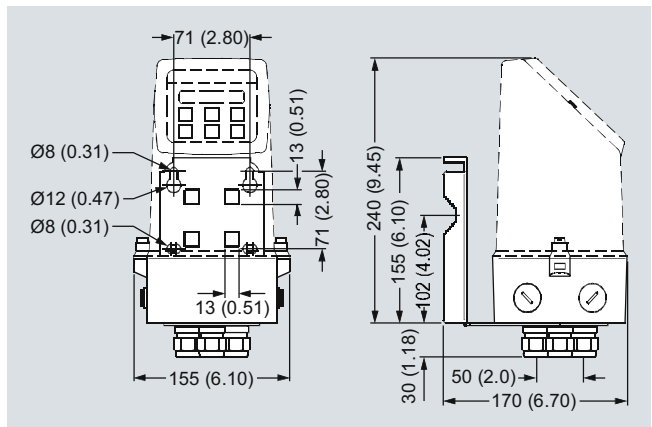

Dimensions in mm (inch)

Flow Measurement SITRANS F C

Transmitter MASS 6000 IP67 compact/remote

Schematics

Electrical connection

Grounding

PE must be connected due to safety class 1 power supply.

Mechanical counters

When mounting a mechanical counter to terminals 57 and 58 (active output), a 1000 µF capacitor must be connected to the terminals 56 and 58. Capacitor + is connected to terminal 56 and capacitor - to terminal 58.

Output cables

If long cables are used in a noisy environment, it is recommended to use shielded cables.

4

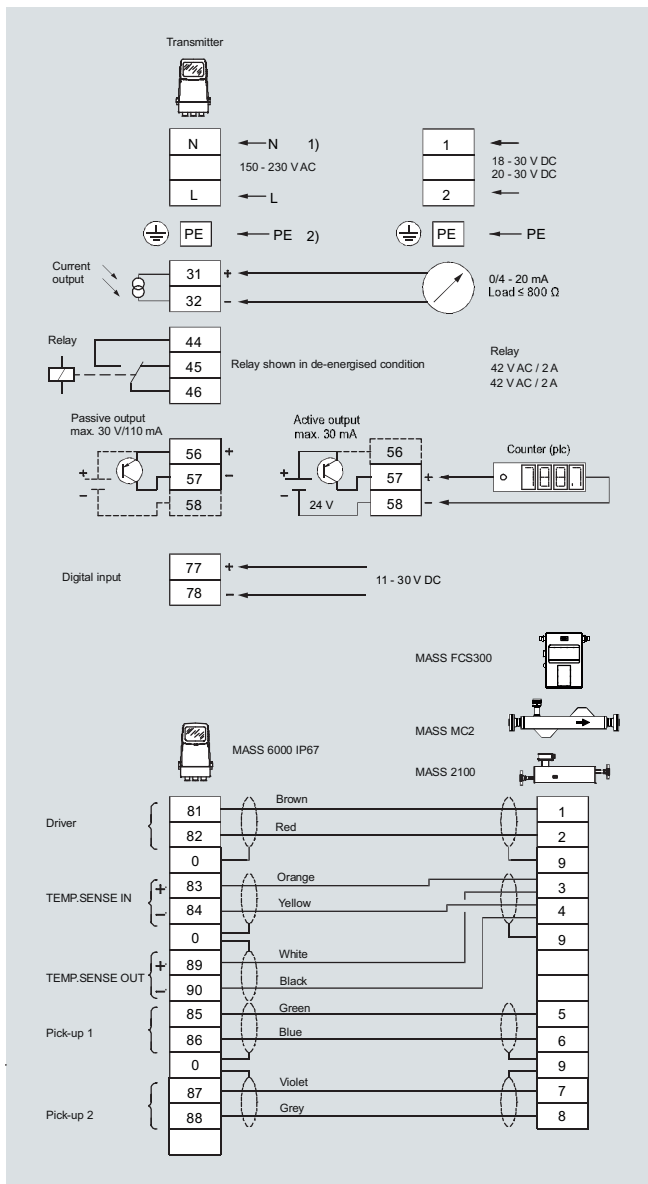

Flow Measurement

SITRANS F C

Transmitter MASS 6000 for 19" insert/19" wall mounting

Overview



MASS 6000 is based on the latest developments within digital signal processing technology – engineered for high performance, fast flow step response, fast batching applications, high immunity against process noise, easy to install, commission and maintain.

The MASS 6000 transmitter delivers true multi parameter measurements i.e.: Mass flow, volume flow, density, temperature and fraction.

The MASS 6000 19" transmitter can be connected to all sensors of types MASS 2100/MC2/FC300 and are available in different versions depending of number of output facilities, Ex protection and grade of enclosure.

Benefits

- Dedicated mass flow chip with the latest ASIC technology
- Fast batching and flow step response with an update rate of true 30 Hz
- Superior noise immunity due to a patented DFT (Discrete Fourier Transformation) algorithm.
- Front end resolution better than 0.35 ns improves zero point stability and enhances dynamic turn-down ratio on flow and density accuracy.
- Advanced diagnosis and service menu enhances troubleshooting and meter verification.
- Built-in batch controller with compensation and monitoring comprising 2 built-in totalizers
- Multi-parameter outputs, individual configurable for mass flow, volume flow, density, temperature or fraction flow such as BRIX or PLATO
- Many output capacities, up to 3 current, 2 frequency/pulse and 2 relay outputs (excludes the possibility of an add-on module)
- Digital input for batch-control, remote zero adjust or forced output mode
- All outputs can be forced to preset value for simulation, verification or calibration purposes.
- User-configurable operation menu with password protection
 - 3 lines, 20 characters display in 11 languages
 - Self-explaining error handling/log in text format
 - Keypad can be used for controlling batch as start/stop/hold/reset

- SENSORPROM technology automatically configures transmitter at start-up providing:
 - Factory pre-programming with calibration data, pipe size, sensor type, output settings
 - Any values or settings changed by users are stored automatically
 - Automatically re-programming any new transmitter without loss of accuracy
 - Transmitter replacement in less than 5 minutes. True "plug & play"
- 4-wire Pt1000 temperature measurement ensures optimum accuracy on mass flow, density and fraction flow
- Fraction flow computation based on a 5th-order algorithm matching all applications
- USM II platform enables fitting of add-on bus modules without loss of functionality.
 - All modules can be fitted as true "plug & play"
 - Module and transmitter automatically configured through the SENSORPROM.
- Transmitter available with ATEX and UL approval
- All electrical connections are easily accessible on the large back plane PCB

Application

SITRANS F C Coriolis mass flowmeters are suitable for all applications within the entire process industry, where there is a demand for accurate flow measurement. The meter can measure both liquids and gases.

The main applications for the MASS 6000 19" transmitter can be found in:

- Chemical and pharmaceutical industries
- Food and beverage industries
- Automotive industry
- Oil and gas industry
- Power generation and utility industry
- Water and waste water industry

Design

The transmitter is designed as a 19" insert as base to be used in:

- 19" rack system
- Panel mounting IP66/NEMA 4
- Back of panel mounting IP20/NEMA 1
- Wall mounting IP66/NEMA 4

The MASS 6000 19" is available as standard or as ATEX-approved transmitter which is to be mounted in the safe area.

Flow Measurement

SITRANS F C

Transmitter MASS 6000 for 19" insert/19" wall mounting

Function

The following functions are available:

- Mass flow rate, volume flow rate, density, temperature, fraction flow
- 2 output versions available as standard:
 - 1 current output, 1 frequency/pulse output, 1 relay output, 1 digital input
 - 3 current outputs, 2 frequency/pulse outputs, 2 relay outputs, 1 digital input
- All outputs can be individually configured with mass, volume, density etc.
- 2 built-in totalizers which can count positive, negative or net
- Low flow cut-off
- Density cut-off or empty pipe cut-off, adjustable
- Flow direction
- Error system consisting of error-log, error pending menu
- Operating time
- Uni/bidirectional flow measurement
- Limit switches with 1 or 2 limits, programmable for flow, density or temperature
- Noise filter setting for optimization of measurement performance under non-ideal application conditions
- Full batch controller
- Automatic zero adjustment menu, with zero point evaluation feed-back
- Full service menu for effective and straight forward application and meter troubleshooting

Technical specifications

Measurement of	Mass flow [kg/s (lbs/min)], volume flow [l/s (gpm)], fraction [%], °Brix, density [kg/m ³ (lbs/ft ³)], temperature [°C (°F)]
Current output	
Current	0 ... 20 mA or 4 ... 20 mA
Load	< 800 Ω
Time constant	0 ... 99.9 s adjustable
Digital output	
Frequency	0 ... 10 kHz, 50 % duty cycle
Time constant	0 ... 30 s adjustable
Active	24 V DC, 30 mA, 1 KΩ ≤ R _{load} ≤ 10 KΩ, short-circuit-protected
Passive	3 ... 30 V DC, max. 110 mA, 1 KΩ ≤ R _{load} ≤ 10 KΩ
Relay	
Type	Change-over relay
Load	42 V/2 A peak
Functions	Error level, error number, limit, direction
Digital input	11 ... 30 V DC
Functionality	Start/hold/continue batch, zero point adjust, reset totalizer 1/2, force output, freeze output
Galvanic isolation	All inputs and outputs are galvanically isolated, isolation voltage 500 V.
Cut-off	
Low-flow	0 ... 9.9 % of maximum flow

Limit function	Mass flow, volume flow, fraction, density, sensor temperature
Totalizer	Two eight-digit counters for forward, net or reverse flow
Display	<ul style="list-style-type: none"> • Background illumination with alphanumeric text, 3 × 20 characters to indicate flow rate, totalized values, settings and faults • Reverse flow indicated by negative sign
Zero point adjustment	Via keypad or remote via digital input
Ambient temperature	
Operation	-20 ... +50 °C (-4 ... +122 °F)
Storage	-40 ... +70 °C (-40 ... +158 °F) (Humidity max. 95 %)
Communication	Add-on modules: HART, PROFIBUS PA and DP, MODBUS RTU RS485, DeviceNet, FOUNDATION Fieldbus H1
Enclosure 19"	
Material	Aluminum/steel (DIN 41494)
Rating	IP20/NEMA 1 to IEC 529 and DIN 40050 (1 mH ₂ O for 30 min.)
Mechanical load	18 ... 1000 Hz random, 3.17G rms, in all directions, to IEC 68-2-36
Supply voltage	<ul style="list-style-type: none"> • 87 ... 253 V AC +10 % ... -10 %, 50 ... 60 Hz • 18 ... 30 V DC or 20 ... 30 V AC
Power consumption	
230 V AC	9 VA max.
24 V DC	6 W I _N = 250 mA, I _{ST} = 2 A (30 ms)
EMC performance	
Emission	EN/IEC 61000-6-4 (Industry)
Immunity	EN/IEC 61000-6-2 (Industry)
Ex approval	[EEx ia] IIC, DEMKO 03 ATEX 135251X
Maintenance	The flowmeter has a built-in error log/pending menu which should be inspected on a regular basis.
Fuse	T 400 mA, T 250 V (IEC 127), not replaceable by operator
Cable	<ul style="list-style-type: none"> • Max. 300 m • C: max. 300 [pF/m]; L_C/R_C: max. 100 [μH/Ω] • The total cable capacity must be max. 200 nF.
Cable glands	The cable gland is available in polyamide, in dimension: PG 13.5

Flow Measurement

SITRANS F C

Transmitter MASS 6000 for 19" insert/19" wall mounting

Selection and Ordering data	Order No.
SITRANS F C MASS 6000 transmitter Transmitter for rack and wall mounting, incl. connection board	7 ME 4 1 1 0 - 2 ■■■■ - ■■ A 0
Enclosure 19 inch insert IP20/NEMA 1 (rack) 19 inch insert in IP66/NEMA 4 (wall mounting)	C E
Output configuration 1 current, 1 frequency, 1 relay 3 current, 2 frequency, 2 relay	A C
Supply voltage 115/230 V AC, 50/60 Hz 24 V AC/DC	1 2
Ex Approvals Standard (No Ex-approval) ATEX UL Class 1, Div. 2 (only IP66/NEMA 4 version)	0 1 5
Display/Keypad With display	1
Serial communication (Only possible to connect to MASS 6000 version with 1 current output) No communication	A
HART	B
PROFIBUS PA Profile 3	F
PROFIBUS DP Profile 3	G
MODBUS RTU RS485	E
DeviceNet	H
FOUNDATION Fieldbus H1	J

Attention (Ex applications)!

MC2 Ex version sensors must only be connected to MASS 6000 standard. The MASS 6000 connection board must be replaced by a connection board approved FDK-083H4294 or FDK-083H4295 (see connection boards/PCB for MASS 6000 and MC2 sensors).

Please also see www.siemens.com/SITRANSFordering for practical examples of ordering

Operating instructions for SITRANS F C MASS 6000 19"



Description	Order No.
• English	A5E02944875

This device is shipped with a Quick Start guide and a CD containing further SITRANS F literature.

All literature is also available for free at:
<http://www.siemens.com/flowdocumentation>

Accessories

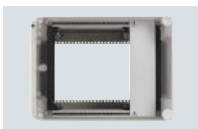
Enclosure

Description	Order No.	
Enclosure in ABS plastic for front panel mounting IP66/NEMA 4, for one 19" transmitter insert (21 TE)	FDK-083F5030	
Enclosure in ABS plastic for front panel mounting IP66/NEMA 4, for two 19" transmitter inserts (42 TE)	FDK-083F5031	
Enclosure in aluminum for back of panel mounting IP20/NEMA 1, for one 19" transmitter insert (21 TE)	FDK-083F5032	

Description	Order No.	
Enclosure in aluminum for back of panel mounting IP20/NEMA 1, for two 19" transmitter inserts (42 TE)	FDK-083F5033	
Front cover (7 TE)	FDK-083F4525	

Cable glands

Description	Order No.	
Cable glands, screwed entries type PG 13.5 in nickel-plated brass, 2 pcs.	FDK-083G3140	
Cable glands, screwed entries type PG 13.5 in polyamide (100 °C (212 °F)) black, 2 pcs.	FDK-083G0228	

Add-on module

Note:

Only possible to connect to MASS 6000 versions with 1 current output.

Description	Order No.	
HART (Ex-i)	FDK-085U0226	
PROFIBUS PA Profile 3 (Ex-i)	FDK-085U0236	
PROFIBUS DP Profile 3	FDK-085U0237	
MODBUS RTU RS485	FDK-085U0234	
FOUNDATION Fieldbus H1 (Ex-i)	A5E02054250	
DeviceNet	FDK-085U0229	

Operating instructions for SITRANS F add-on modules

Description	Order No.
HART	
• English	A5E03089708
PROFIBUS PA/DP	
• English	A5E00726137
• German	A5E01026429
MODBUS	
• English	A5E00753974
• German	A5E03089262
• Spanish	A5E03089278
• French	A5E03089265
FOUNDATION Fieldbus	
• English	A5E02318728
• German	A5E02488856
• Spanish	A5E02512177
• French	A5E02512169
DeviceNet	
• English	A5E03089720



This device is shipped with a Quick Start guide and a CD containing further SITRANS F C literature.

Flow Measurement

SITRANS F C

Transmitter MASS 6000 for 19" insert/19" wall mounting

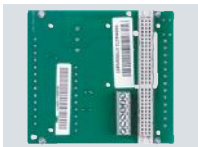
Connection boards/PCB for MASS 6000 and MASS 2100 sensors

Description	Version	Order No.	
Connection board MASS 6000 for 19" IP20 rack mounting version	24 V 115/230 V	FDK-083H4272	
Connection board MASS 6000 EEx [ia] IIC for 19" IP20 rack mounting version	24 V 115/230 V	FDK-083H4273	
Connection board MASS 6000 for 19" wall mounting version, for enclosure FDK-083F5037/FDK-083F5038	24 V 115/230 V	FDK-083H4274	
Connection board MASS 6000 EEx [ia] IIC for 19" wall mounting version, for enclosure FDK-083F5037/FDK-083F5038	24 V 115/230 V	FDK-083H4275	

Connection boards/PCB for MASS 6000 and MC2 sensors

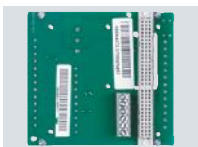
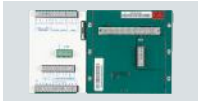

Description	Version	Order No.	
Connection board MASS 6000 for 19" IP20 rack mounting version	24 V 115/230 V	FDK-083H4272	
Connection board MASS 6000 for Ex application ¹⁾ and 19" IP20 rack mounting version (connection board MASS 6000 to MC2 sensors Ex-approved)	24 V 115/230 V	FDK-083H4294	
Connection board MASS 6000 for 19" wall mounting version, for enclosure FDK-083F5037/FDK-083F5038	24 V 115/230 V	FDK-083H4274	
Connection board MASS 6000 for Ex application ¹⁾ and 19" wall mounting version (connection board MASS 6000 to MC2 sensors Ex-approved), for enclosure FDK-083F5037/FDK-083F5038	24 V 115/230 V	FDK-083H4295	

¹⁾ Attention (Ex application): MC2 Ex version sensors must only be connected to connection board FDK-083H4294 or FDK-083H4295.

Description	Order No.	
Wall mounting enclosure for MASS 6000 19" version IP66/NEMA 4 (21 TE) with connection board/PCB for Ex application connected to MC2 Ex sensors	FDK-083H4296	

Spare parts 19" versions

Enclosure (without PCB, connection board)

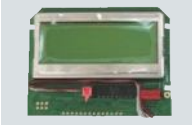
Description	Order No.	
Enclosure in ABS plastic for wall mounting IP66/NEMA 4, for one 19" transmitter insert (21 TE), connection board not included	FDK-083F5037	
Enclosure in ABS plastic for wall mounting IP66/NEMA 4, for two 19" transmitter inserts (42 TE), connection board not included	FDK-083F5038	
Display for MASS 6000 19" insert/19" wall mounting. Order the Display and Keypad accessory from MASS 6000 IP67 compact/remote (FDK-085U1039) and use the display for replacement	FDK-085U1039	

Flow Measurement SITRANS F C

Transmitter MASS 6000
for 19" insert/19" wall mounting

Dimensional drawings

Transmitter 19" insert

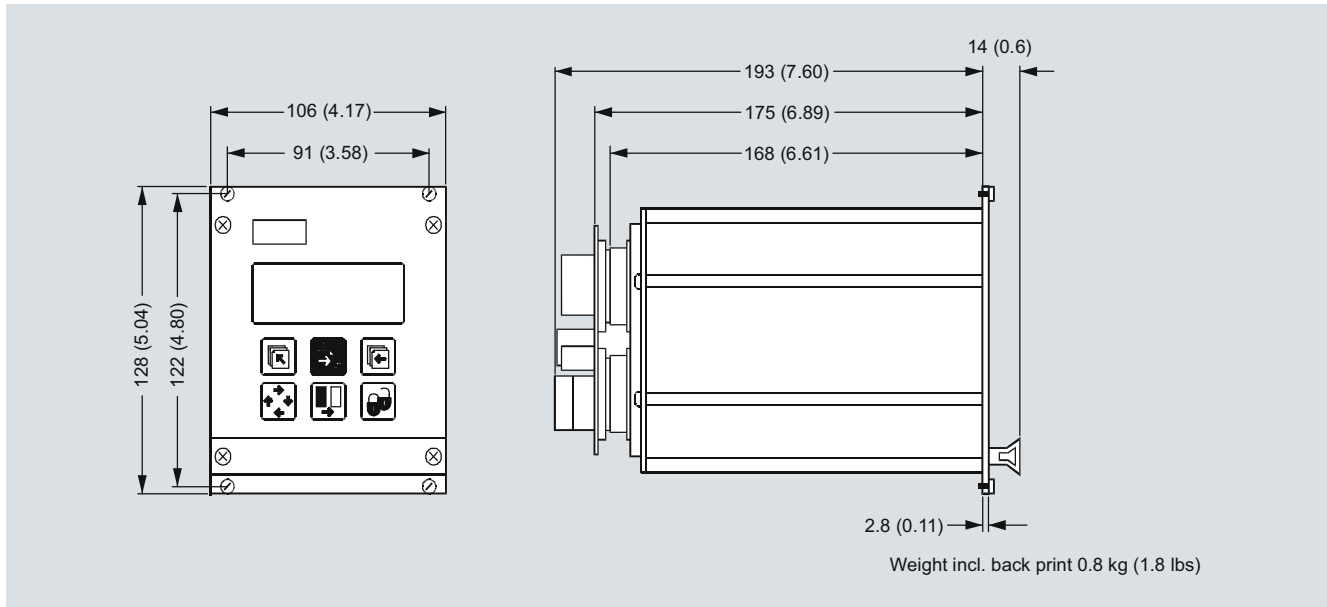

Dimensions in mm (inch)

Transmitter 19" wall mounting

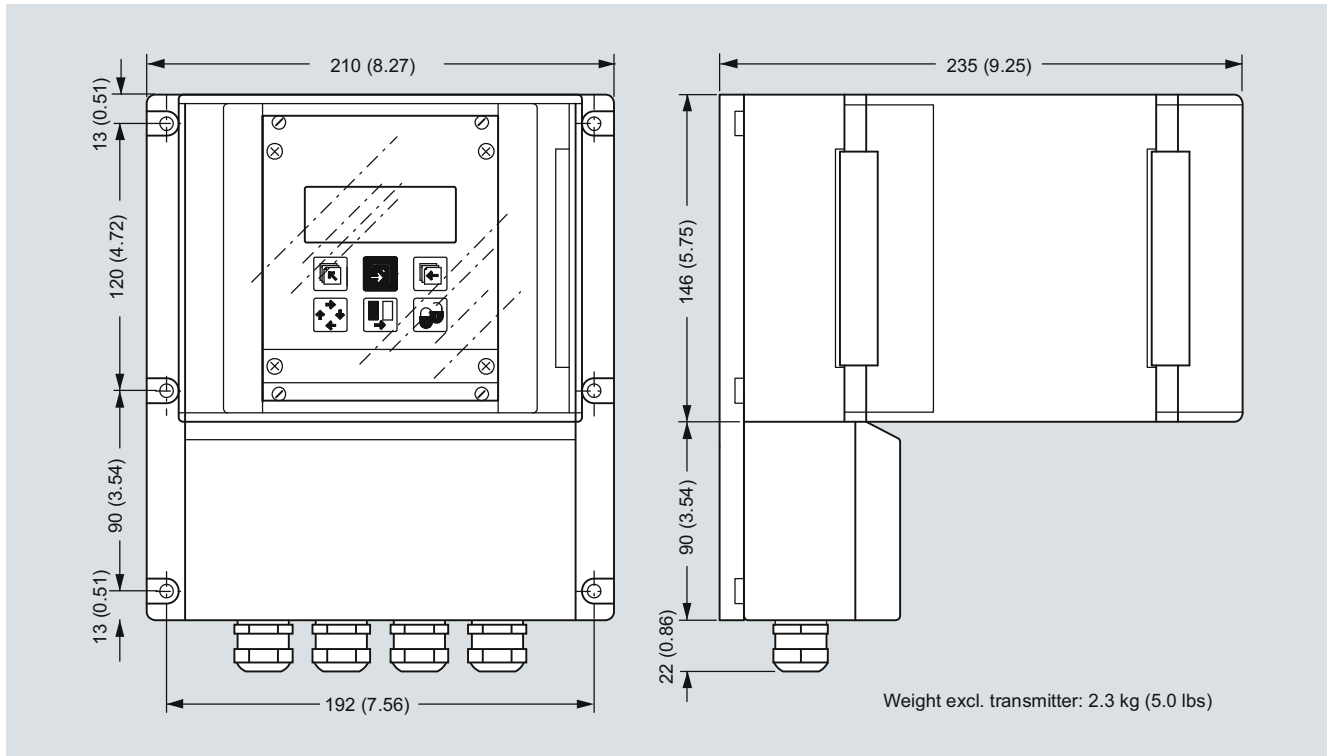

Dimensions in mm (inch)

Flow Measurement SITRANS F C

Transmitter MASS 6000 for 19" insert/19" wall mounting

Transmitter 19" front of panel

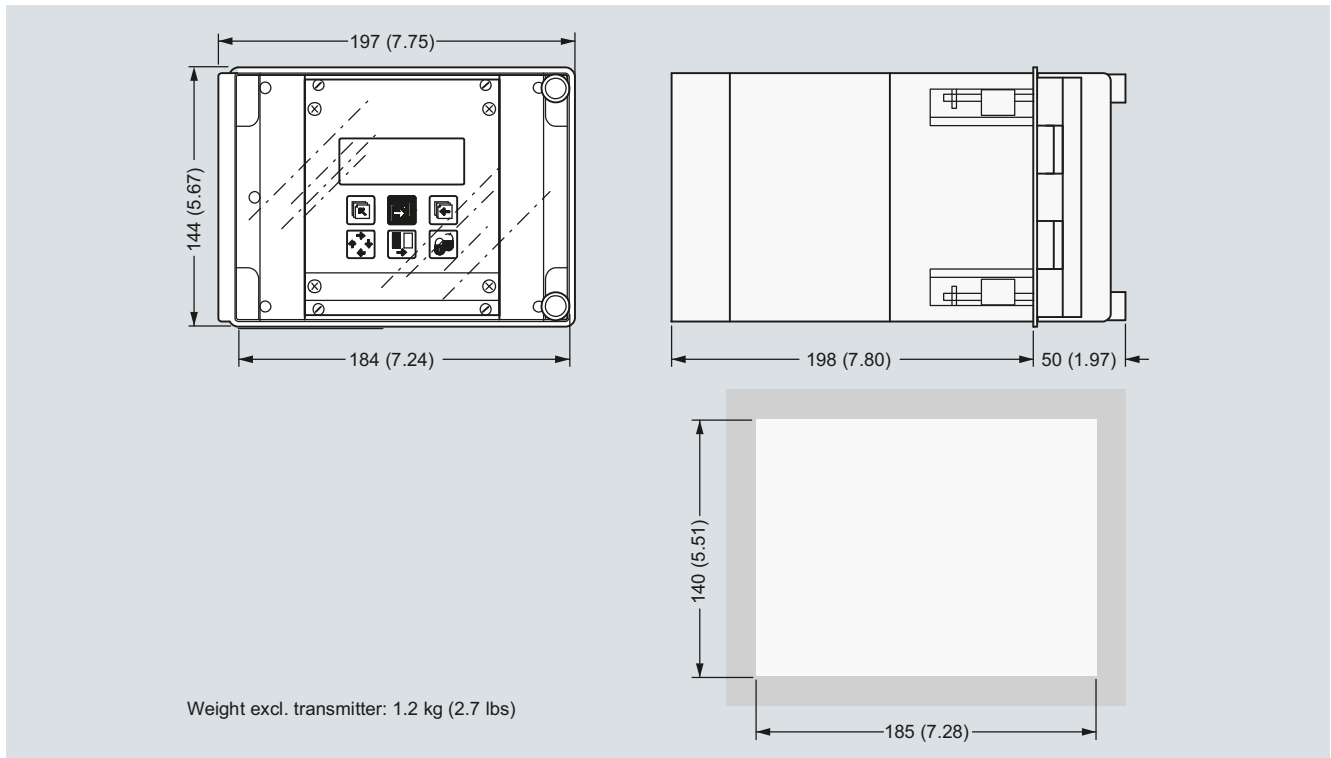

Dimensions in mm (inch)

Transmitter back of panel

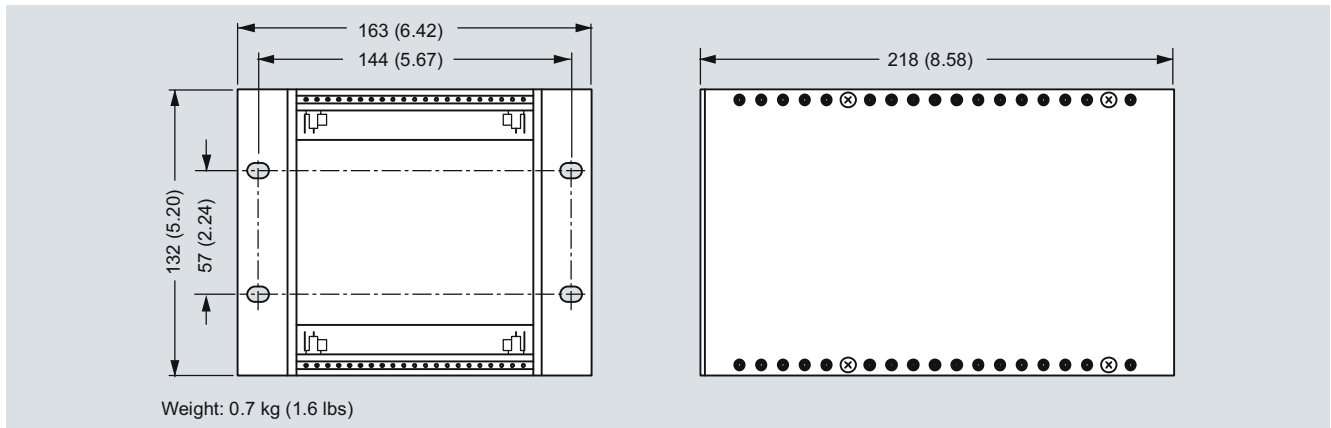

Dimensions in mm (inch)

Transmitter back of panel, 42 TE

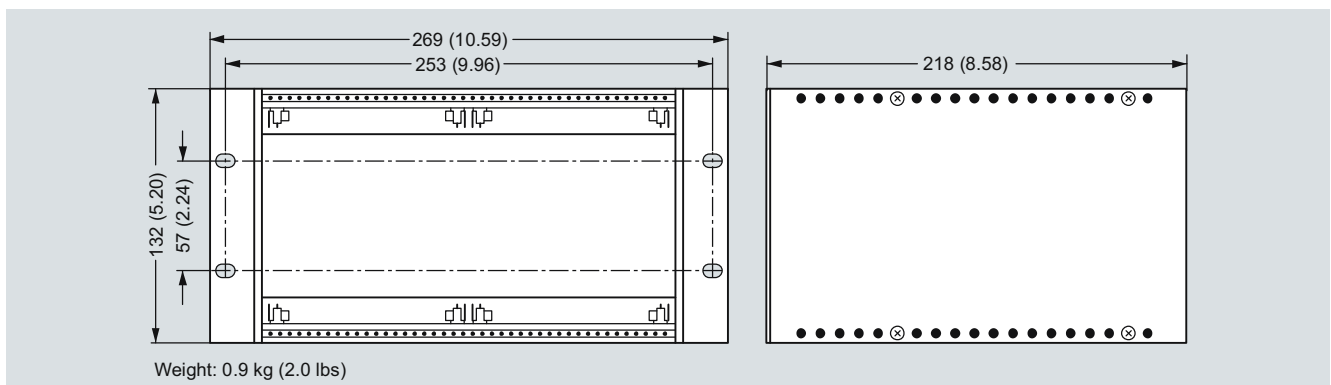

Dimensions in mm (inch)

Schematics

Electrical connection

Grounding

PE must be connected due to safety class 1 power supply.

Mechanical counters

When mounting a mechanical counter to terminals 57 and 58 (active output), a 1000 µF capacitor must be connected to the terminals 56 and 58. Capacitor + is connected to terminal 56 and capacitor - to terminal 58.

Output cables

If long cables are used in noisy environment, it is recommended to use shielded cables.

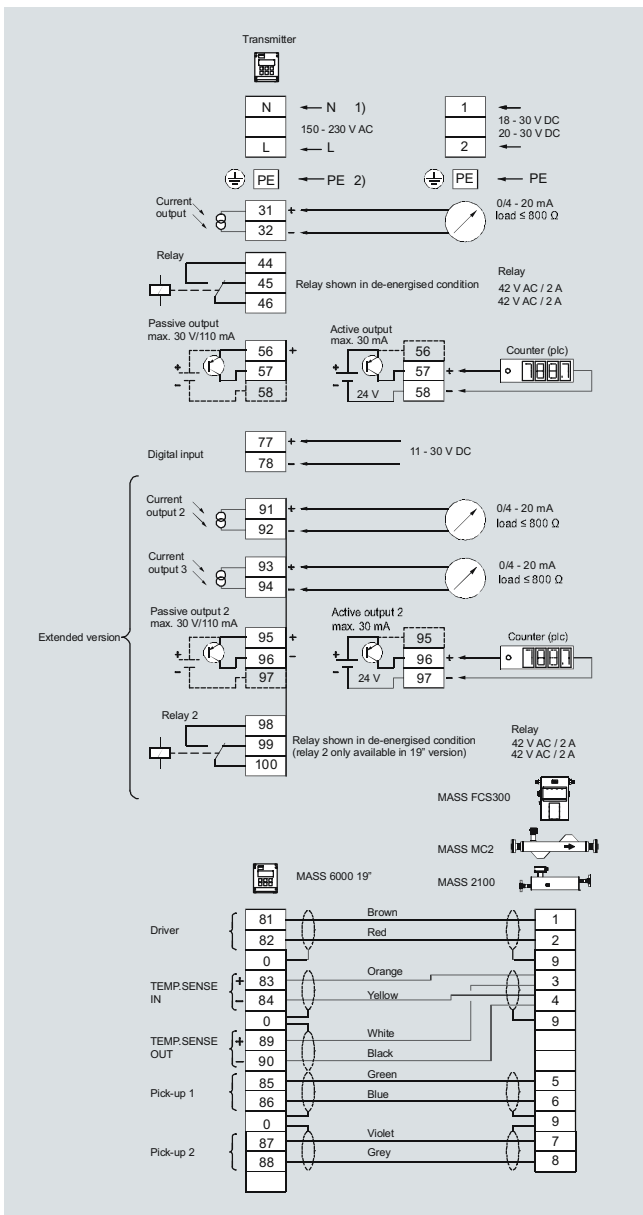

Flow Measurement

SITRANS F C

Transmitter MASS 6000 Ex d compact/remote

Overview



MASS 6000 is based on the latest developments within digital signal processing technology – engineered for high performance, fast flow step response, fast batching applications, high immunity against process noise, easy to install, commission and maintain.

The MASS 6000 transmitter delivers true multiparameter measurements i.e.: Mass flow, volume flow, density, temperature and fraction flow.

The MASS 6000 Ex d transmitter is manufactured in stainless steel (AISI 316L/1.4404) and able to withstand harsh installation conditions in hazardous applications within the process and chemical industry. The conservative choice of material guarantees the user a low cost of ownership and a long trouble-free lifetime.

The Ex d can be compact mounted on all sensors of type MASS 2100 DI 3 to DI 40, and can be used in remote version for all types of MASS 2100.

Benefits

- Fully stainless steel flameproof EEx d enclosure, ensuring optimum cost of ownership
- Intrinsically safe keypad and display directly programmable in hazardous area
- ATEX-approved transmitter which can be mounted in hazardous area Zone 1 or Zone 2.
- Sensor and transmitter interface intrinsically safe EEx ia IIC
- Exchange of transmitter directly in hazardous area without shut-down of process pipe line due to ia IIC sensor/transmitter interface.
- Dedicated mass flow chip with the latest ASIC technology
- Fast batching and flow step response with an update rate of true 30 Hz
- Superior noise immunity due to a patented DFT (Discrete Fourier Transformation) algorithm
- Front end resolution better than 0.35 ns improves zero point stability and enhances dynamic turn-down ratio on flow and density accuracy.
- Advanced diagnosis and service menu enhances troubleshooting and meter verification.
- Built-in batch controller with compensation and monitoring comprising 2 built-in totalizers
- Multi-parameter outputs, individual configurable for mass flow, volume flow, density, temperature or fraction flow such as BRIX or PLATO
- 1 current output, 1 frequency/pulse and 1 relay as standard output
- Current output can be selected as passive or active output

- Digital input for batch-control, remote zero adjust or forced output mode
- All outputs can be forced to preset value for simulation, verification or calibration purposes.
- User-configurable operation menu with password protection
 - 3 lines, 20 characters display in 11 languages
 - Self-explaining error handling/log in text format
 - Keypad can be used for controlling batch as start/stop/hold/reset
- SENSORPROM technology automatically configures transmitter at start-up providing:
 - Factory pre-programming with calibration data, pipe size, sensor type, output settings
 - Any values or settings changed by users are stored automatically
 - Automatically re-programming any new transmitter without loss of accuracy
 - Transmitter replacement in less than 5 minutes. True "plug & play"
- 4-wire Pt1000 temperature measurement ensures optimum accuracy on mass flow, density and fraction flow
- Fraction flow computation based on a 5th-order algorithm matching all applications
- USM II platform enables fitting of add-on bus modules without loss of functionality:
 - All modules can be fitted as true "plug & play"
 - Module and transmitter automatically configured through the SENSORPROM
- Installation of the transmitter to the sensor is simple "plug & play" via the sensor pedestal.

Application

SITRANS F C mass flowmeters are suitable for all applications within the entire process industry where there is a demand for accurate flow measurement in hazardous area. The meter can measure both liquids and gases.

The main applications for the MASS 6000 Ex d transmitter can be found in:

- Chemical process industry
- Pharmaceutical industries
- Automotive industry
- Oil and gas industry
- Power generation and utility industry

Design

The transmitter is designed in an Ex d compact stainless steel enclosure which can be compact mounted on the MASS 2100 sensor range DI 3 to DI 40, and remote mounted for the entire sensor series.

The MASS 6000 Ex d is available as standard with 1 current, 1 frequency/pulse and 1 relay output and can be fitted with add-on modules for bus communication.

- Flameproof „d“ enclosure
- Enclosure stainless steel, IP67/NEMA 4X as compact and IP66/NEMA 4 as remote
- Supply voltage 24 V AC/DC
- MASS 6000 Ex d is ATEX approved together with all MASS 2100 sensors, but can **not** be used together with MC2 Ex versions

Transmitter MASS 6000 Ex d compact/remote

Function

The following functions are available:

- Mass flow rate, volume flow rate, density, temperature, fraction flow
- 1 current output, 1 frequency/pulse output, 1 relay output, 1 digital input
- All outputs can be individually configured with mass, volume, density etc.
- 2 built-in totalizers which can count positive, negative or net
- Low flow cut-off
- Density cut-off or empty pipe cut-off, adjustable
- Flow direction
- Error system consisting of error-log, error pending menu
- Operating time
- Uni/bidirectional flow measurement
- Limit switches with 1 or 2 limits, programmable for flow, density or temperature
- Noise filter setting for optimization of measurement performance under non-ideal application conditions
- Full batch controller
- Automatic zero adjustment menu, with zero point evaluation feed back
- Full service menu for effective and straight forward application and meter troubleshooting

Technical specifications

Measurement of	Mass flow [kg/s (lbs/min)], volume flow [l/s (gpm)], fraction [%], °Brix, density [kg/m ³ (lbs/ft ³)], temperature [°C (°F)]
Current output	Classified EEx ia, selectable as active or passive outputs. Default setting is active mode.
Current	0 ... 20 mA or 4 ... 20 mA
Load	< 350 Ω
Time constant	0 ... 99.9 s adjustable
Current characteristics	
Active mode	$U_o = 24\text{ V}$, $I_o = 82\text{ mA}$, $P_o = 0.5\text{ W}$, $C_o = 125\text{ nF}$, $L_o = 2.5\text{ mH}$
Passive mode (max input from external barrier)	$U_i = 30\text{ V}$, $I_i = 100\text{ mA}$, $P_i = 0.75\text{ W}$, $C_i = 52\text{ nF}$, $L_i = 100\text{ μH}$
Digital output	
Frequency	0 ... 10 kHz, 50 % duty cycle
Time constant	0.1 ... 30 s adjustable
Passive	6 ... 30 V DC, max. 110 mA, $1\text{ k}\Omega \leq R_{load} \leq 10\text{ k}\Omega$
Output characteristics	
Active mode	Not available
Passive mode (max input from external barrier)	$U_i = 30\text{ V}$, $I_i = 100\text{ mA}$, $P_i = 0.75\text{ W}$, $C_i = 52\text{ nF}$, $L_i = 100\text{ μH}$
Relay	
Type	Change-over relay
Load	30 V/100 mA
Functionality	Error level, error number, limit, direction
Output characteristics	$U_i = 30\text{ V}$, $I_i = 100\text{ mA}$, $P_i = 0.75\text{ W}$, $C_i = 0\text{ nF}$, $L_i = 0\text{ mH}$

Digital input	11 ... 30 V DC ($R_i = 13.6\text{ k}\Omega$)
Functionality	Start/hold/continue batch, zero point adjust, reset totalizer 1/2, force output, freeze output
Output characteristics	$U_i = 30\text{ V}$, $I_i = 3.45\text{ mA}$, $P_i = 0.10\text{ W}$, $C_i = 0\text{ nF}$, $L_i = 0\text{ mH}$
Galvanic isolation	All inputs and outputs are galvanically isolated, isolation voltage 500 V.
Cut-off	
Low-flow	0 ... 9.9 % of maximum flow
Empty pipe	Detection of empty sensor
Density	0 ... 2.9 g/cm ³
Totalizer	Two eight-digit counters for forward, net or reverse flow
Display	<ul style="list-style-type: none"> • Background illumination with alphanumeric text, 3 × 20 characters to indicate flow rate, totalized values, settings and faults. Time constant as current output • Reverse flow indicated by negative sign
Zero point adjustment	Via keypad or remote via digital input
Ambient temperature	
Operation	-20 ... +50 °C (-4 ... +122 °F)
Storage	-40 ... +70 °C (-40 ... +158 °F) (Humidity max. 95 %)
Communication	Add-on modules: HART, PROFIBUS PA, FOUNDATION Fieldbus H1
HART	
Active mode	$U_o = 6.88\text{ V}$, $I_o = 330\text{ mA}$, $P_o = 0.57\text{ W}$, $C_o = 20\text{ nF}$, $L_o = 100\text{ μH}$
Passive mode (max input from external barrier)	$U_i = 10\text{ V}$, $I_i = 200\text{ mA}$, $P_i = 0.5\text{ W}$, $C_i = 0\text{ nF}$, $L_i = 0\text{ μH}$
PROFIBUS PA	
Active mode	Not available
Passive mode	$U_i = 17.5\text{ V}$, $I_i = 380\text{ mA}$, $P_i = 5.32\text{ W}$, $C_i = 5\text{ nF}$, $L_i = 10\text{ μH}$
FOUNDATION Fieldbus H1	
Active mode	Not available
Passive mode	$U_i = 17.5\text{ V}$, $I_i = 380\text{ mA}$
Enclosure	
Material	Stainless steel AAISI 316/1.4435
Rating	<ul style="list-style-type: none"> • Compact mounted on sensor: IP67/NEMA 4X to IEC 529 and DIN 40050 • Remote mounted: IP66/NEMA 4 to IEC 529 and DIN 40050
Load	18 ... 1000 Hz random, 1.14 G rms, in all directions, to IEC 68-2-36, Curve E

Flow Measurement

SITRANS F C

Transmitter MASS 6000 Ex d compact/remote

Supply voltage

24 V AC

- Range 20 ... 30 V AC
- Power consumption 6 VA $I_N = 250$ mA, $I_{ST} = 2$ A (30 ms)
- Power supply The power supply shall be from a safety isolating transformer. Maximal cable core is 1.5 mm²

24 V DC

- Range 18 ... 30 V DC
- Power consumption 6 VA $I_N = 250$ mA, $I_{ST} = 2$ A (30 ms)
- Power supply The power supply shall be from a safety isolating transformer. Maximal cable core is 1.5 mm².

EMC performance

Emission EN/IEC 61000-6-4 (Industry)
 Immunity EN/IEC 61000-6-2 (Industry)

NAMUR

Within the value limits according to "Allgemeine Anforderung" with error criteria A in accordance with NE 21

Ex approval

EEx de [ia/ib] IIC T6, DEMKO 03 ATEX 135253X

Temperature class:

- T6 Process liquid temperature:
 - $T < 85$ °C (185 °F)
- T5
 - 85 °C $< T < 100$ °C (185 °F $< T < 212$ °F)
- T4
 - 100 °C $< T < 135$ °C (212 °F $< T < 275$ °F)
- T3
 - 135 °C $< T < 180$ °C (275 °F $< T < 356$ °F)

Selection and Ordering data

Order No.

SITRANS F C MASS 6000 transmitter

7ME4110-

Transmitter Ex d for remote mounting inclusive of wall mounting kit

2 ■ ■ ■ ■ - ■ ■ ■ ■

Enclosure

Ex d SS with 5 m (16.5 ft) cable
 Ex d SS with 10 m (32.8 ft) cable
 Ex d SS with 25 m (82.0 ft) cable

G
H
J

Output configuration

1 current, 1 frequency, 1 relay

A

Supply voltage

24V AC/DC

2

Ex approvals

ATEX

1

Display/Keypad

With display

1

Serial communication

No communication
 HART
 PROFIBUS PA Profile 3
 FOUNDATION Fieldbus H1

A
B
F
J

Cable gland

M20

1

Operating instructions for SITRANS F C MASS 6000 Ex d

Description

Order No.

- English

A5E02944883

This device is shipped with a Quick Start guide and a CD containing further SITRANS F literature.

All literature is also available for free at:
<http://www.siemens.com/flowdocumentation>

Note:

Only communication modules with Ex approvals are allowed.

Please also see www.siemens.com/SITRANSOrdering for practical examples of ordering

Transmitter MASS 6000 Ex d compact/remote

Selection and Ordering data

Accessories

Add-on module for remote and compact MASS 6000 Ex d

Description	Order No.
HART (Ex-i)	FDK-085U0226
PROFIBUS PA Profile 3 (Ex-i)	FDK-085U0236
FOUNDATION Fieldbus H1 (Ex-i)	A5E02054250



Operating instructions for SITRANS F add-on modules

Description	Order No.
HART	
• English	A5E03089708
PROFIBUS PA/DP	
• English	A5E00726137
• German	A5E01026429
FOUNDATION Fieldbus	
• English	A5E02318728
• German	A5E02488856
• Spanish	A5E02512177
• French	A5E02512169

This device is shipped with a Quick Start guide and a CD containing further SITRANS F C literature.

Spare parts for MASS 6000 Ex d

Description	Order No.
Wall mounting kit for remote Ex d inclusive of sensor cable of	
• 5 m	FDK-083H0231
• 10 m	FDK-083H0232
• 25 m	FDK-083H0233
Ex d transmitter insert	FDK-083H3061
Front lid	FDK-085U2373
Screws and washers between pedestal and sensor (4 pcs.), seal (1 pc.)	FDK-085U2374
Display and keypad	FDK-083H0235



Dimensional drawings

MASS 6000 Ex d compact version

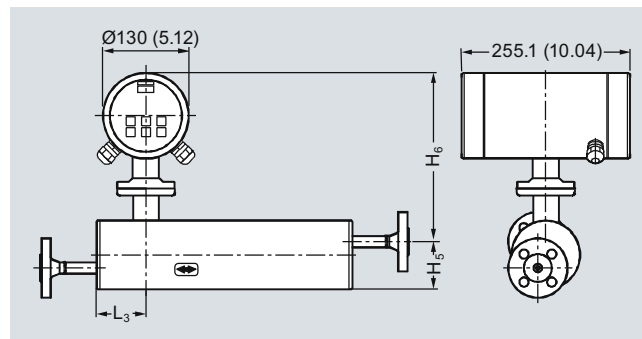

Dimensions in mm (inch)

Sensor size [Di (inch)]	L ₃ [mm (inch)]	H ₅ [mm (inch)]	H ₆ [mm (inch)]	H ₅ + H ₆ [mm (inch)]
3 (1/8)	75 (2.95)	82 (3.23)	247 (9.72)	329 (12.95)
6 (1/4)	62 (2.44)	72 (2.83)	257 (10.12)	329 (12.95)
15 (1/2)	75 (2.95)	87 (3.43)	267 (10.51)	354 (13.94)
25 (1)	75 (2.95)	173 (6.81)	271 (10.67)	444 (17.48)
40 (1 1/2)	75 (2.95)	227 (8.94)	271 (10.67)	498 (19.61)

Flow Measurement SITRANS F C

Transmitter MASS 6000 Ex d compact/remote

Schematics

Electrical connection compact or remote

4

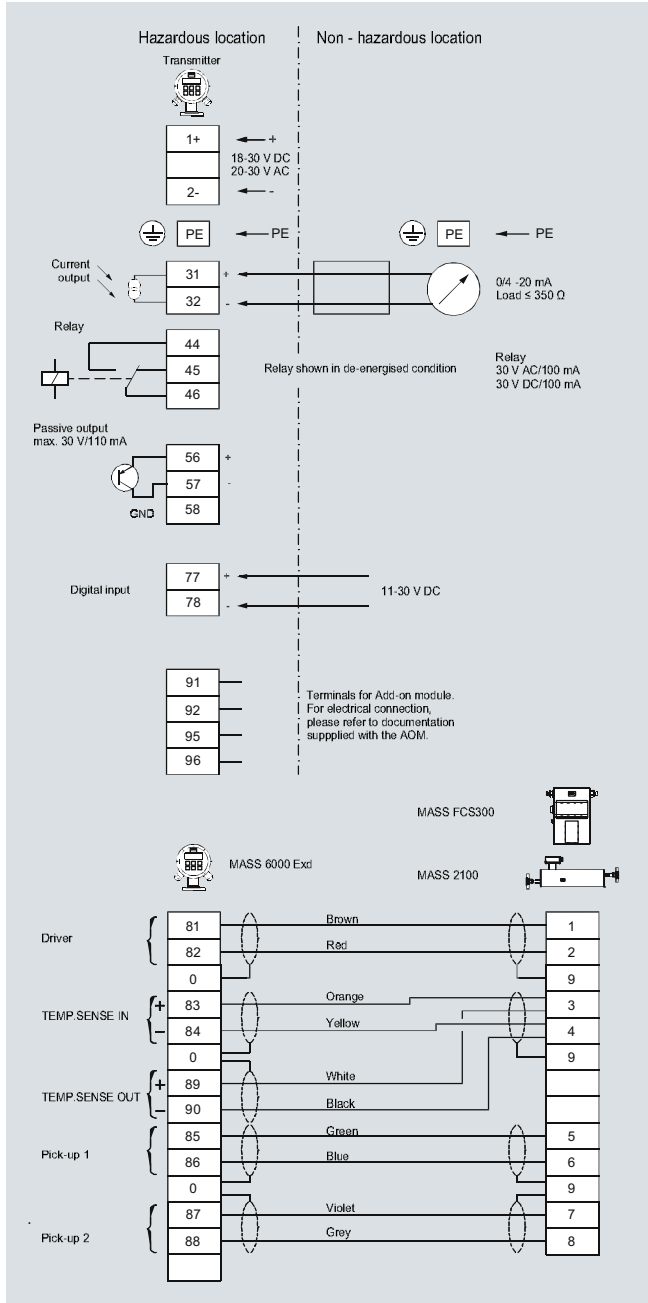

Flow Measurement SITRANS F C

Transmitter MASS 6000 Ex d compact/remote

MASS 6000 Ex d remote version

Weight: 3 kg (6.6 lbs)

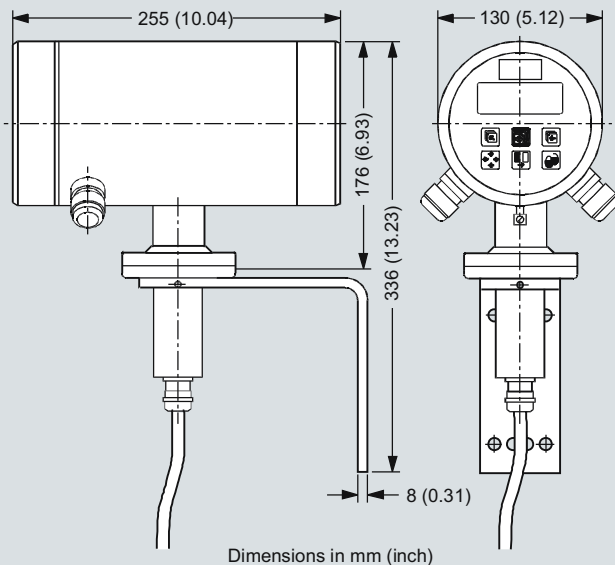
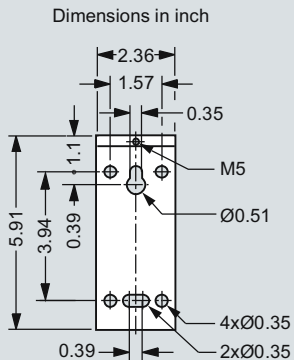
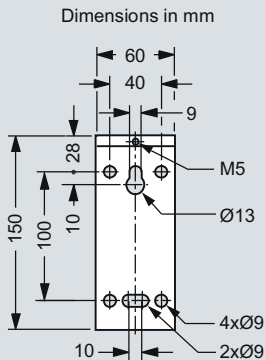

Flow Measurement

SITRANS F C

Transmitter SIFLOW FC070

Overview



SIFLOW FC070 is based on the latest developments within the digital processing technology – engineered for high performance, fast flow step response, immunity against process generated noise, easy to install, commission and maintain.

SIFLOW FC070 is available in two versions:

- SIFLOW FC070 Standard
- SIFLOW FC070 Ex CT

The SIFLOW FC070 transmitter delivers true multi-parameter measurements i.e. mass flow, volume flow, density, temperature and fraction.

SIFLOW FC070 is designed for integration in a variety of automation systems, i.e.:

- Central mounted in S7-300, C7
- Decentralized in ET 200M for use with S7-300 and S7-400 as PROFIBUS DP/Profinet masters
- Decentralized in ET 200M for use with any automation system using standardized PROFIBUS DP/Profinet masters
- Stand-alone via a MODBUS RTU master, i.e. SIMATIC PDM

The SIFLOW FC070 transmitter can be connected to all sensors of types MASS 2100, MC2, FCS200 and FC300.

Benefits

- Easy integration in SIMATIC S7 and PCS 7
- Support of SIMATIC PDM configuration tool via MODBUS
- Dedicated mass flow chip with high-performance ASIC technology
- True 30 Hz update rate securing fast batching and step response
- Superior noise immunity due to a patented DFT (Discrete Fourier Transformation) algorithm
- Front end resolution better than 0.35 ns improves zero point stability and enhances dynamic turn-down ratio on flow and density accuracy.
- Advanced diagnostics enhancing troubleshooting and meter verification
- Built-in batch controller with two-stage control and compensation
- Digital outputs for direct batch control, frequency/pulse
- MODBUS RTU RS232/RS485 interface for connection to SIMATIC PDM or any other MODBUS master

- Digital input for batch control, zero adjust
- Extensive simulation options for measurement values, I/O and errors easy communication/fault-finding
- Multiple LED's for easy indication of flow, error and I/O state
- SENSORPROM technology automatically configures the transmitter during start-up providing:
 - Factory pre-programming with calibration data, pipe size, sensor type and I/O settings
 - Any values or settings changed by the user is stored automatically
 - Automatically re-programming of a new transmitter, without loss of settings and accuracy
 - Transmitter replacement in less than 30 seconds
- Four-wire Pt1000 measurement ensuring optimum accuracy mass flow, density and fraction flow
- Fraction flow computation based on a 5th-order algorithm matching all applications
- SIFLOW FC070 Ex CT is Custody transfer approved, according to OIML R 139 (Compressed gaseous fuel measuring systems for vehicles), when using the redundant digital output or the encrypted ActiveX component for SIMATIC touch panels.
- Free of charge ActiveX component for SIMATIC touch panels, enables encrypted sensor process values to be communicated between SIFLOW FC070 Ex CT and SIMATIC touch panels

Application

SIFLOW FC070 mass flowmeters are suitable for all applications within the entire process industry, where there is a demand for accurate flow measurement. The meters are suitable for measuring on liquid and gas.

The main applications for the SIFLOW FC070 transmitter can be found in the following industries:

- Food and beverage
- Pharmaceutical
- Automotive
- Oil and gas
- Power generation and utility
- Water and waste water

Design

SIFLOW FC070 is designed in an IP20 SIMATIC S7-300 enclosure and for use in central and de-central cabinets where sensors: FCS200, FC300, MASS 2100 and MC2 are remotely mounted.

Function

The following key functionalities are available:

- Mass flow rate, volume flow rate, density, temperature and fraction flow
- Two built-in totalizers which can freely be set for counting mass, volume or fraction
- 1 frequency/pulse/batch output
- 1 phase shifted 90°/180° two stage digital output
- 1 digital input
- Low flow cut-off
- Empty pipe detection
- Noise filter settings for different applications
- Simulation
- Two-stage batch controller
- Automatic zero point adjustment with zero point evaluation feed back
- Limit functionality
- Comprehensive status and error reporting

Technical specifications

Measurement of	Mass flow, volume flow, density, sensor temperature, fraction A flow, fraction B flow, fraction A in %	MODBUS RS485	<ul style="list-style-type: none"> • Max. baudrate: 115 200 baud • Max. line length: 1200 m at 115 200 baud • Signal level: according to EIA-RS485 • Bus termination: Integrated. Can be enabled by inserting wire jumpers.
Measurement functions		Galvanic isolation	All inputs, outputs and communication interfaces are galvanically isolated. Isolation voltage: 500 V
• Totalizer 1	Totalization of mass flow, volume-flow, fraction A, fraction B	Power	
• Totalizer 2	Totalization of mass flow, volume-flow, fraction A, fraction B	Supply	24 V DC nominal
• Single and 2-stage batch function	Batching function with the use of one or two outputs for dosing in high and low speed	Tolerance	20.4 V DC ... 28.8 V DC
• 4 programmable limits	4 programmable high/low limits for mass flow, volume flow, density, sensor temperature, fraction A flow, fraction B flow, fraction A in %. Limits will generate an alarm if reached.	Consumption	Max. 6 W
		Fuse	T1 A/125 V, not replaceable by operator
Digital input		Environment	
Functions	Start batch, stop batch, start/stop batch, hold/continue batch, reset totalizer 1, reset totalizer 2, reset totalizer 1 and 2, zero adjust, force frequency output, freeze frequency output	Ambient temperature	<ul style="list-style-type: none"> • Storage -40 ... +70 °C (-40 ... +158 °F) • Operation 0 ... 60 °C (32 ... 140 °F)
High signal	<ul style="list-style-type: none"> • Nominal voltage: 24 V DC • Lower limit: 15 V DC • Upper limit: 30 V DC • Current: 2 ... 15 mA 	Operation conditions	Horizontally mounted rail. For vertically mounted rail, the maximum operating temperature is +45 °C (+113 °F).
Low signal	<ul style="list-style-type: none"> • Nominal voltage: 0 V DC • Lower limit: -3 V DC • Upper limit: 5 V DC • Current: -15 ... 15 mA 	Altitude	<ul style="list-style-type: none"> • Operation: -1000 ... 2000 m (pressure 795 ... 1080 hPa)
Input	Approx. 10 kΩ	Enclosure	
Switching	Max. 100 Hz.	Material	Noryl, color: anthracite
		Rating	IP20/NEMA 2 according to IEC 60529
Digital output 1 and 2		Mechanical load	According to SIMATIC standards (S7-300 devices)
Functions	<ul style="list-style-type: none"> • Output 1: Pulse, frequency, redundancy pulse, redundancy frequency 2-stage batch, batch • Output 2: Redundancy pulse, redundancy frequency, 2-stage batch 	Approvals Ex	
Voltage supply	3 ... 30 V DC (passive output)	SIFLOW FC070 Standard	CE, C-UL, ATEX II 3G EEx nA IIC
Switching current	Max. 30 mA at 30 V DC	SIFLOW FC070 Ex CT	CE, C-UL, UL Haz.Loc., FM, ATEX II (1)G [Ex ia] IIC Ga / II 3G Ex nA IIC T4 Gc and IEC Ex Ex nA [ia] IIC T4
Voltage drop	≤ 3 V DC at max. current	Approvals Custody transfer	
Leakage current	≤ 0.4 mA at max. voltage 30 V DC	SIFLOW FC070 Ex CT	PTB Germany approval no.: 5.4.11/11.22 OIML R 139 - Compressed gaseous fuel measuring systems for vehicles
Load resistance	1 ... 10 kΩ	Electromagnetic compatibility	Requirements of EMC law; Noise immunity according to IEC 61000-6-2, tested according to: IEC 61000-4-2, 61000-4-3, IEC 61000-4-4, IEC 61000-4-5, IEC 61000-4-6
Switching frequency	0 ... 12 kHz 50 % duty cycle		Emitted interference according to EN 50081-2, tested according to EN 55011, class A, group 1
Functions	Pulse, frequency, redundancy pulse, redundancy frequency 2-stage batch, batch	NAMUR	Within the limits according to "Allgemeine Anforderung" with error criteria A in accordance with NE21
Communication		Programming tools	
MODBUS RS232C	<ul style="list-style-type: none"> • Max. baudrate: 115 200 baud • Max. line length: 15 m at 115 200 baud • Signal level: according to EIA-RS232C 	SIMATIC S7	Configuration trough backplane P-BUS and PLC program
		SIMATIC PCS7	Configuration trough backplane P-BUS and PLC/WinCC face-plates
		SIMATIC PDM	Through MODBUS port RS232C and RS485

Flow Measurement

SITRANS F C

Transmitter SIFLOW FC070

Selection and Ordering data

Description	Order No.
SIFLOW FC070 flow transmitter Remember to order 40 pin front plug connector.	7ME4120-2DH20-0EA0
40 pin front plug with screw contacts	6ES7392-1AM00-0AA0
40 pin plug with spring contacts	6ES7392-1BM01-0AA0
SIFLOW FC070 Ex CT flow transmitter Remember to order 20 pin front plug connector.	7ME4120-2DH21-0EA0
20 pin plug with spring contacts	6ES7392-1BJ00-0AA0
20 pin front plug with screw contacts	6ES7392-1AJ00-0AA0

Operating instructions for SITRANS F C SIFLOW FC070

Description	Order No.
SIFLOW FC070 system manual	
• English	A5E00924779
• German	A5E00924776
SIFLOW FC070 with S7	
• English	A5E02254228
• German	A5E02665536
• French	A5E02591639

This device is shipped with a Quick Start guide and a CD containing further SITRANS F literature.

All literature is also available for free at:
<http://www.siemens.com/flowdocumentation>

Accessories

Description	Order No.
Cable with multiplug for connecting MASS 2100, FCS200 and FC300 sensors	
• 5 m (16.4 ft)	FDK-083H3015
• 10 m (32.8 ft)	FDK-083H3016
• 25 m (82 ft)	FDK-083H3017
• 50 m (164 ft)	FDK-083H3018
• 75 m (246 ft)	FDK-083H3054
• 150 m (492 ft)	FDK-083H3055
Cable without multiplug for connecting MC2 sensors	
• 10 m (32.8 ft)	FDK-083H3001
• 25 m (82 ft)	FDK-083H3002
• 75 m (246 ft)	FDK-083H3003
• 150 m (492 ft)	FDK-083H3004
SIMATIC S7-300 rail The mechanical mounting rack of the SIMATIC S7-300	
• 160 mm (6.3")	6ES7 390-1AB60-0AA0
• 482 mm (18.9")	6ES7 390-1AE80-0AA0
• 530 mm (20.8")	6ES7 390-1AF30-0AA0
• 830 mm (32.7")	6ES7 390-1AJ30-0AA0
• 2000 mm (78.7")	6ES7 390-1BC00-0AA0
Shield connecting element For mounting on S7-300 rail. 80 mm wide with 2 rows for 4 shield terminal elements each (no shield terminal elements included)	6ES7390-5AA00-0AA0
Shield terminal element for 1 cable with 3 to 8 mm in dia. 2 pieces	6ES7390-5BA00-0AA0
Shield terminal element for 1 cable with 4 to 13 mm in dia. 2 pieces	6ES7390-5CA00-0AA0
SIFLOW FC070 Demo suitcase with MASS 2100 DI 1.5 sensor and SIMATIC HMI TP 177B touch panel	A5E01075465
Power supply	6ES7307-1BA01-0AA0

Flow Measurement SITRANS F C

Transmitter SIFLOW FC070



ActiveX component, enables encrypted sensor process values to be communicated between SIFLOW FC070 Ex CT and SIMATIC touch panels

Dimensional drawings

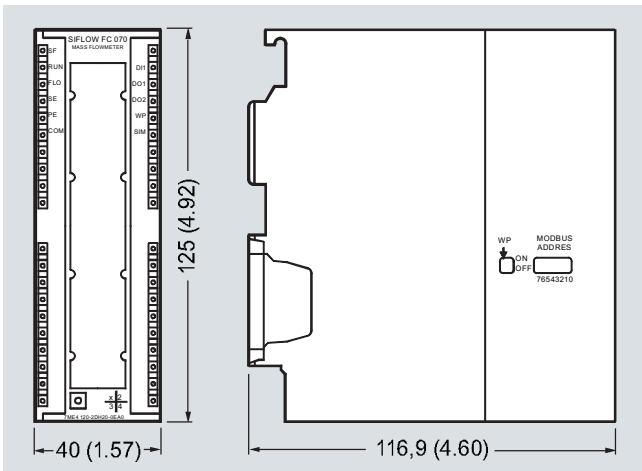

SIFLOW FC070, dimensions in mm (inch)

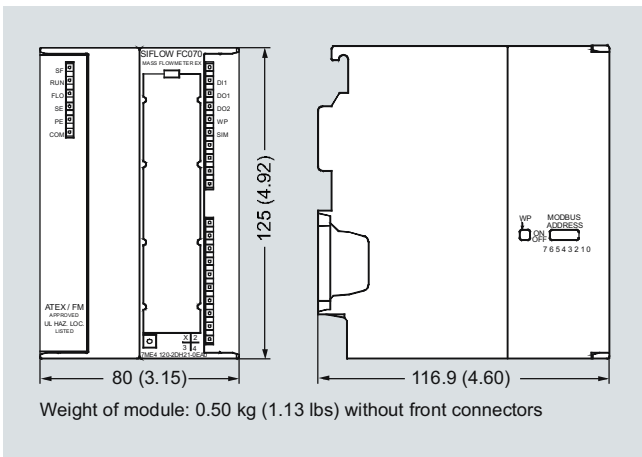

SIFLOW FC070 Ex CT, dimensions in mm (inch)

Schematics

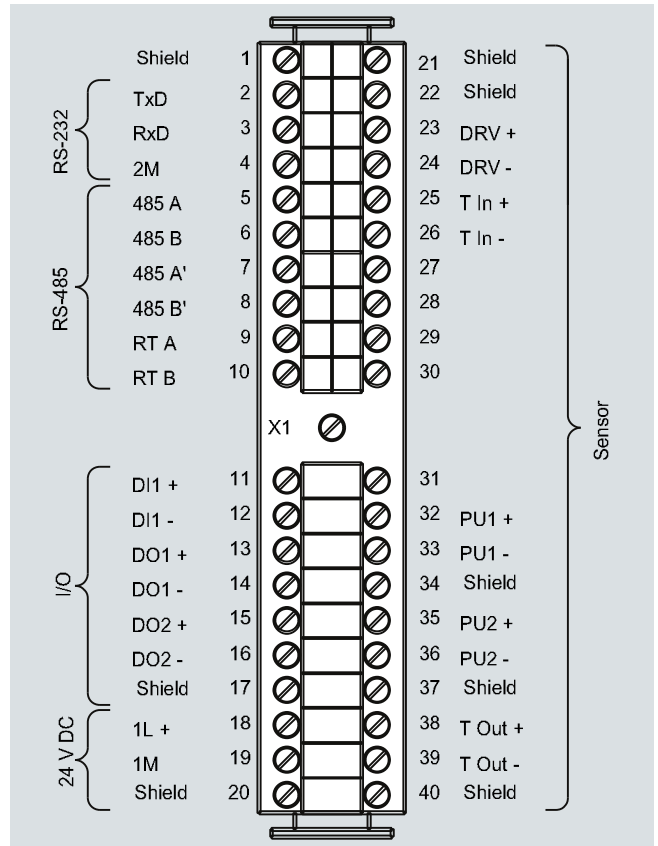

SIFLOW FC070, electrical connection

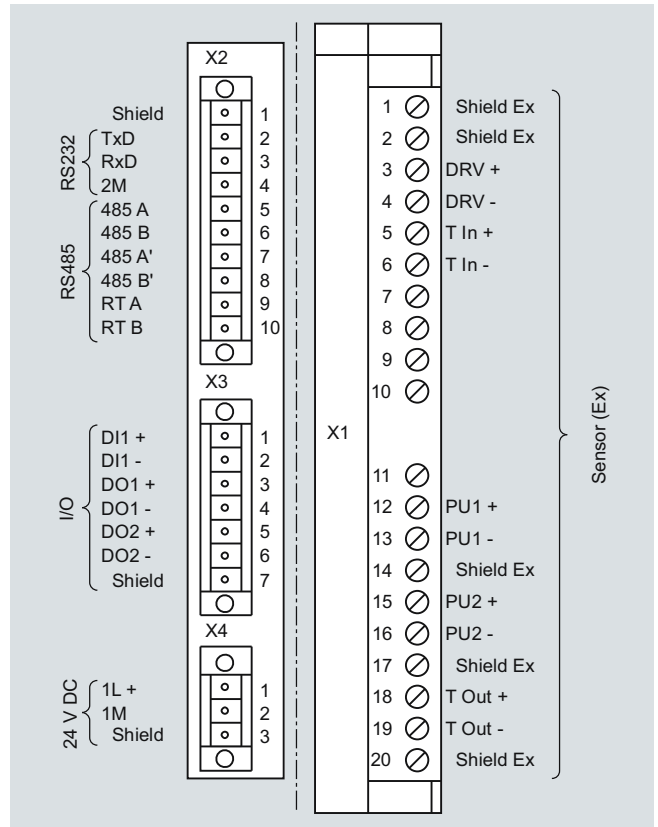

SIFLOW FC070 Ex CT, electrical connection

Flow Measurement

SITRANS F C

Flow sensor SITRANS FCS200

Overview



SITRANS FCS200 (DN10, DN 15 and DN 25) is a Coriolis sensor specialized for accurate mass flow measurement of gases.

The sensor offers superior performance in terms of flow accuracy and turn down ratio. The ultra compact sensor design makes installation, replacement and commissioning very straight forward and easy.

Benefits

- High accuracy gas measurement
- Approved for use in hazardous area
- DN 10 and DN 15 is custody transfer approved, according to OIML R 139 (Compressed gaseous fuel measuring systems for vehicles). For custody transfer applications SIFLOW FC070 Ex CT must be used.
- Self-draining in both horizontal and vertical orientation
- Pt1000 temperature measurement for optimum accuracy
- SENSORPROM enabling true "plug & play"
- Rigid enclosure design reducing influence from pipeline vibration and thermal stress
- High-pressure measurement up to 350 bar (5076 psi)
- Ultra compact sensor design with space-saving split flow

Application

SITRANS FCS200 is designed for measurement of gases and is suitable for use in the oil and gas industry:

- Filling of gas bottles
- CNG dispensers
- Metering of general gas applications

Design

SITRANS FCS200 is available in DN 10, DN 15 and DN 25.

The sensor consists of 2 parallel measuring pipes, welded directly onto a flow splitter at each end of the sensor to eliminate a direct coupling to the process connectors and significantly reduce effects from external vibrations. The flow-splitters are welded directly onto a rigid sensor housing which acts as a mechanical low pass filter.

The wetted parts of SITRANS FCS200 are available in Hastelloy C22, while the enclosure is made of stainless steel AISI 304/1.4301 with a grade of encapsulation of IP67.

The two black rupture discs are designed to prevent the enclosure from overpressure.

Function

The flow measuring principle is based on the Coriolis effect. See "System information SITRANS F C".

Integration

The complete flowmeter consists of the sensor (SITRANS FCS200) and a transmitter SITRANS F C MASS 6000 or SIFLOW FC070. All communication options are available for MASS 6000.

The sensor is shipped with a SENSORPROM memory unit containing all information about calibration data, device identity and factory pre-programming of transmitter settings.

Installation guidelines

Siemens Flow Instruments recommends installing the sensor in one of the following ways:

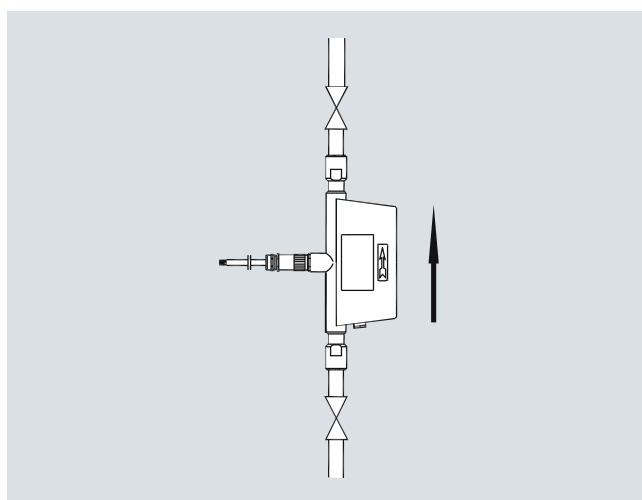

Vertical orientation with an upwards flow

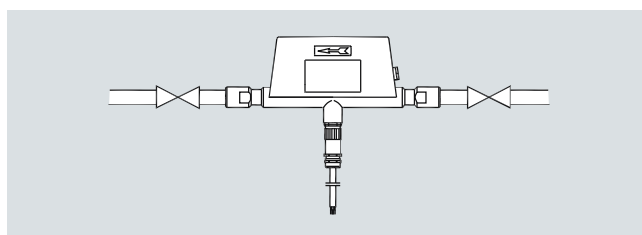

Horizontal installation, tubes up

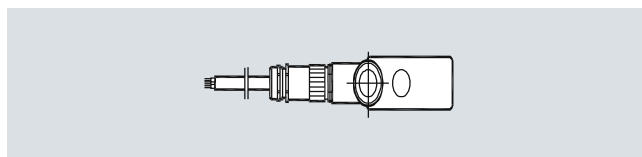

Horizontal installation, tubes sideways

Technical specifications

Sensor size	DN 10	DN 15	DN 25
Mass Flow			
Accuracy [% of rate]		± 0.5	
Repeatability [% of rate]		± 0.25	
Max. zero point error [kg/h (lbs/h)]	0.25 (0.55)	1.2 (2.65)	3.0 (6.6)
Measuring range [kg/min (lbs/min)]	0 ... 42 (0 ... 92.6)	0 ... 200 (0 ... 440.9)	0 ... 500 (0 ... 1102.3)
Process temperature	-40 ... +125 °C (-40 ... +257 °F)		
Ambient temperature	-40 ... +60 °C (-40 ... +140 °F)		
Temperature error	0.5 °C (0.9 °F)		
Pressure [bar (psi)]	350 (5076)	350 (5076)	214 (3104)
Enclosure grade	IP66/IP67 (EN 60529)		
Material			
Measuring pipe and splitter	Hastelloy C22/2.4602	Hastelloy C22/2.4602	Stainless steel
Enclosure and connection (flanges)	Stainless steel		
Connection thread	¼" NPT ½" NPT ½" VCO	½" NPT ¾" NPT 1" NPT ¾" VCO	1" NPT 1½" NPT 1" VCO
Ex approval	II 1/2 G Ex ia IIC T5/T4		
• ATEX	Ex ia IIC T5/T4		
• IECEx	Class I, Div 1, Groups A, B, C and D		
• FM			
Weight approx.	2.8 kg (6.2 lb)	6.0 kg (13.2 lb)	11 kg (24.2 lb)
Approvals Custody transfer			
DN 10/DN 15	PTB Germany approval nr: 5.4.11/11.22 OIML R 139 - Compressed gaseous fuel measuring systems for vehicles		

Characteristic curves

DN 10

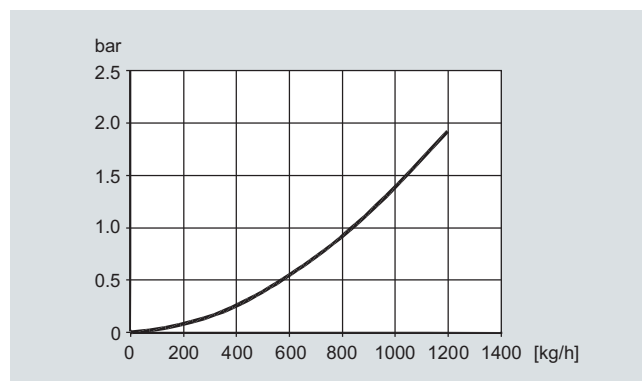

DN 15

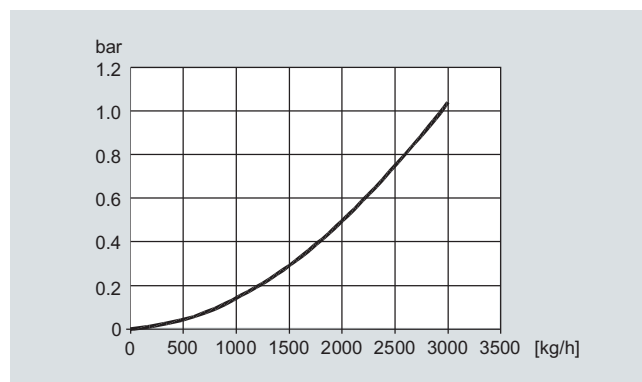

DN 25

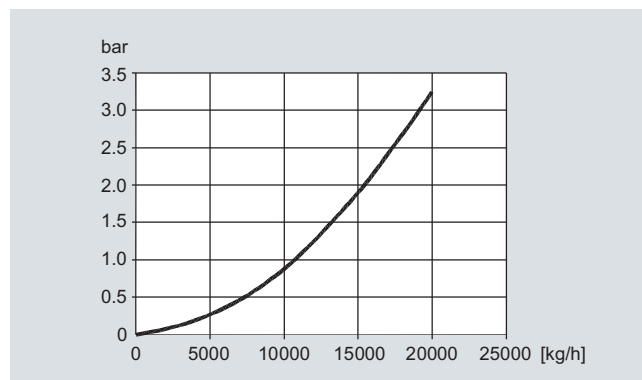

The pressure drop as a function of capacity for CNG with a pressure of 200 bar (2900 psi) and an ambient temperature of 20 °C (68 °F).

Flow Measurement

SITRANS F C

Flow sensor SITRANS FCS200

Selection and Ordering data	Order No.
SITRANS F C Flow sensors	
SITRANS FCS200 sensor, without heating jacket	7 ME 4 5 0 0 -
Sensor size and material	
DN 10, Hastelloy C22/2.4602	2 D
DN 15, Hastelloy C22/2.4602	2 E
DN 25, Stainless steel AISI 316Ti/1.4571	1 F
Pressure	
PN 214 (DN 25)	K
PN 350 (DN 10 and DN 15)	N
Process connection/flange	
½"/VCO	7 1
¾"/VCO	7 2
1"/VCO	7 3
¼"/NPT pipe thread	8 1
½"/NPT pipe thread	8 2
¾"/NPT pipe thread	8 3
1"/NPT pipe thread	8 4
1½"/NPT pipe thread	8 5
Configuration	
Standard	1
Transmitter	
None	A
Cable	
No cable	A
Calibration	
Standard calibration	1

Selection and Ordering data	Order code
Additional information	
Please add "-Z" to Order No. and specify Order code(s) and plain text.	
Pressure testing certificate PED: 97/23/EC	C11
Material certificate EN 10204-3.1	C12
NDT-Penetrant inspection report ISO 3452	C13
Factory certificate according to EN 10204 2.2	C14
Factory certificate according to EN 10204 2.1	C15
Tag name plate, stainless steel	Y17

Accessories

Description	Order No.
Cable with multiple plug	
5 m (16.4 ft)	FDK-083H3015
Standard blue cable between SIFLOW FC070/MASS 6000 and FCS200,	10 m (32.8 ft) FDK-083H3016
25 m (82 ft) FDK-083H3017	
5 x 2 x 0.34 mm ² twisted and screened in pairs.	50 m (164 ft) FDK-083H3018
Temperature range -20 °C ... +110 °C (-4 °F ... +230 °F)	75 m (246 ft) FDK-083H3054
	150 m (492 ft) FDK-083H3055

Spare parts

Description	Order No.
Multiple plug for cable mounting	FDK-083H5056
2 kB SENSORPROM unit (Sensor Serial No. and Order No. must be specified by ordering)	FDK-083H4410

Dimensional drawings

SITRANS FCS200, DN 10 ... DN 15

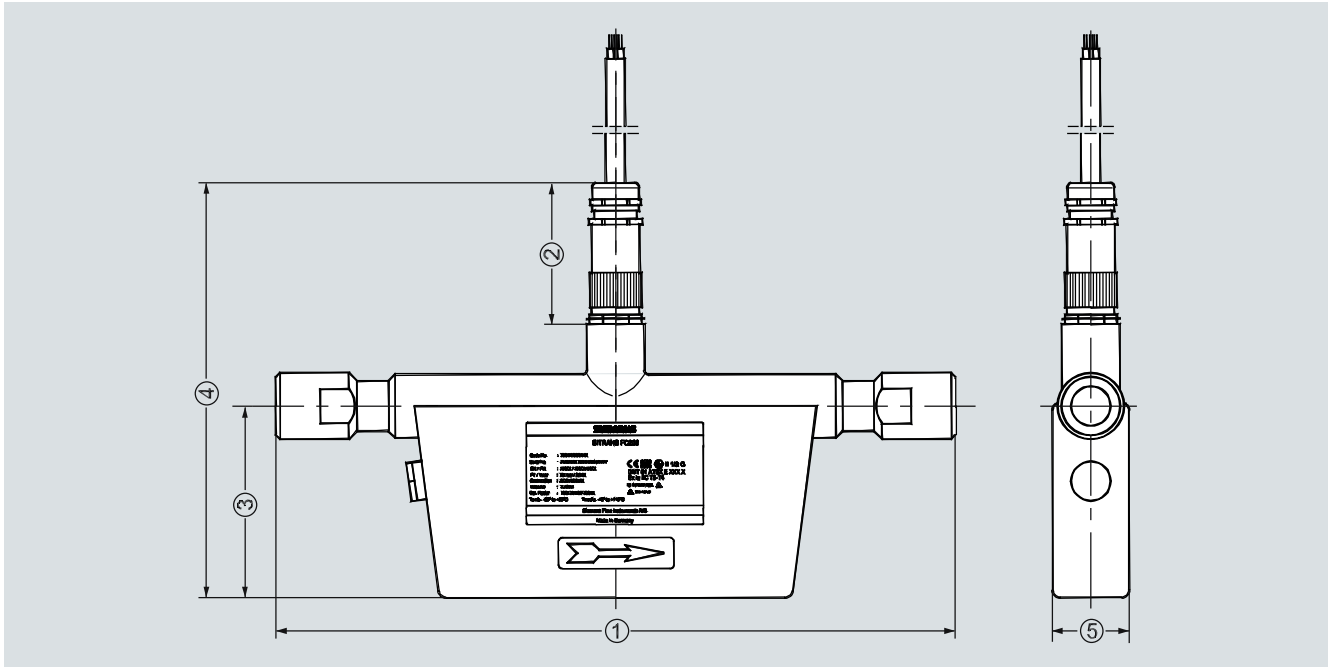

SITRANS FCS200, DN 10 ... DN 15, dimensions in mm (inch)

Position	DN 10 with NPT connectors mm (inch)	DN 10 with VCO connectors mm (inch)	DN 15 mm (inch)
(1)	350 (13.78)	330 (12.99)	450 (17.72)
(2)	72 (2.84)	72 (2.84)	72 (2.84)
(3)	100 (3.94)	100 (3.94)	148 (5.83)
(4)	204 (8.03)	204 (8.03)	253 (9.96)
(5)	40 (1.57)	40 (1.57)	48 (1.89)

Flow Measurement SITRANS F C

Flow sensor SITRANS FCS200

SITRANS FCS200, DN 25

4

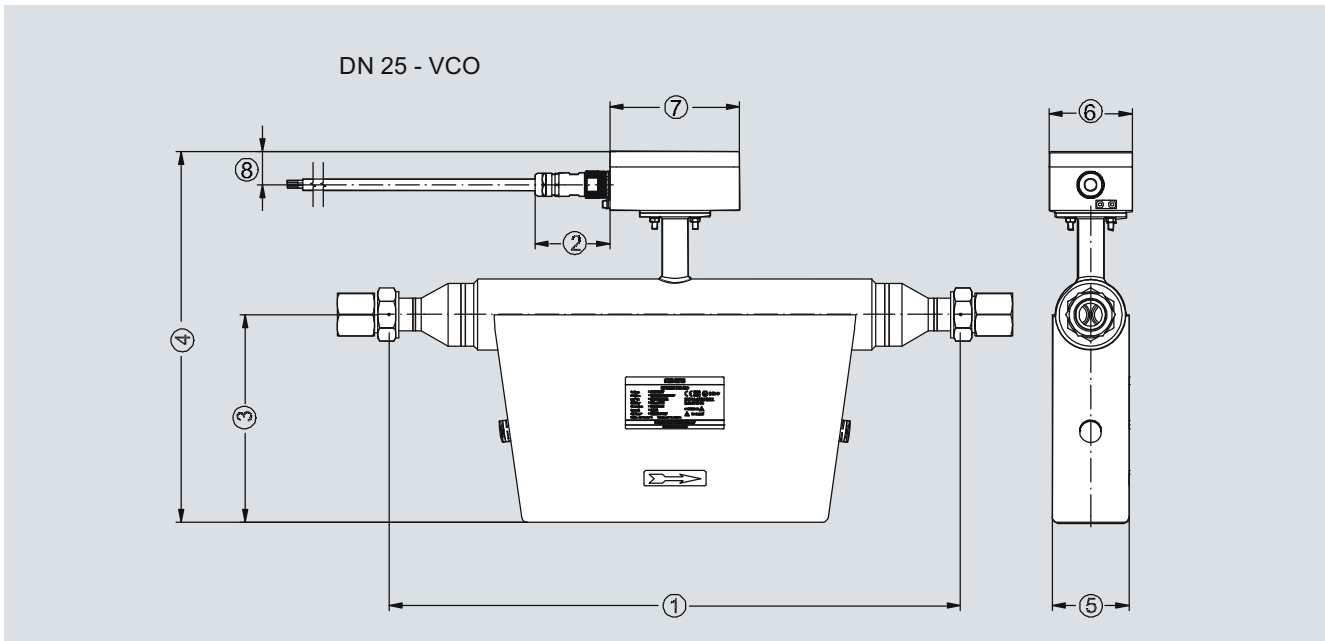
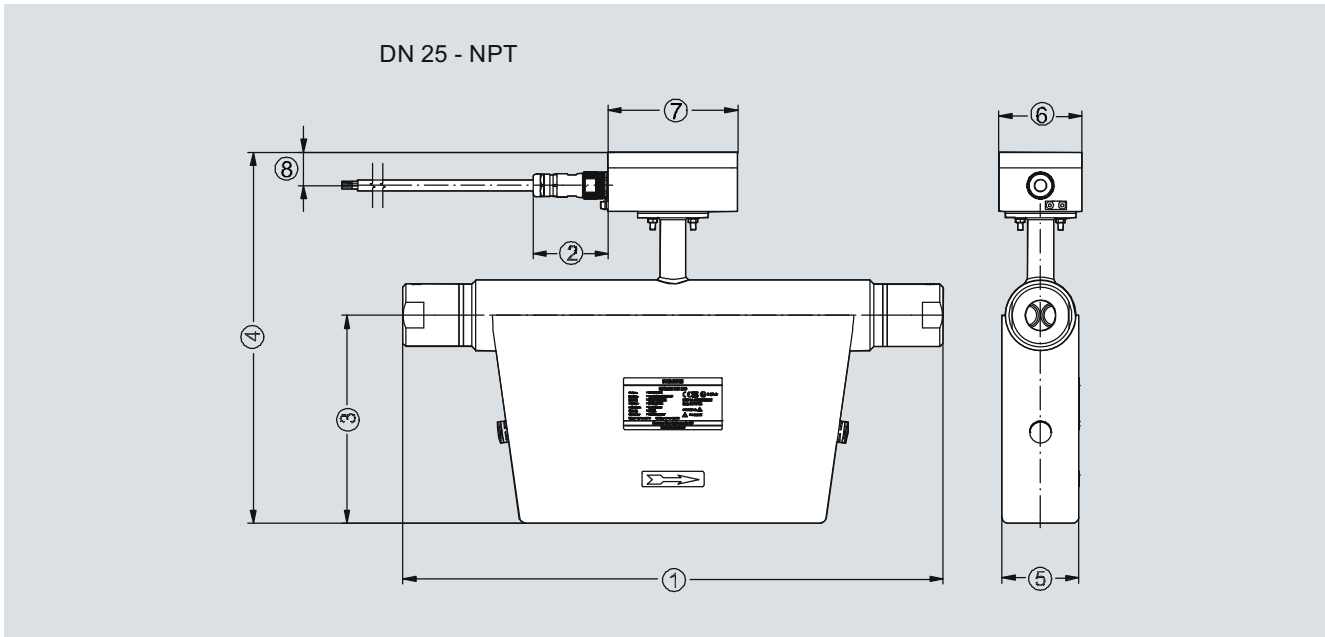

SITRANS FCS200, DN 25, dimensions in mm (inch)

Position	DN 25 with NPT connection mm (inch)	DN 25 with VCO connection mm (inch)
(1)	520 (20.47)	550 (21.65)
(2)	72 (2.84)	72 (2.84)
(3)	200 (7.87)	200 (7.87)
(4)	357 (14.77)	357 (14.77)
(5)	74 (2.91)	74 (2.91)
(6)	80 (3.15)	80 (3.15)
(7)	125 (4.92)	125 (4.92)
(8)	32 (1.26)	32 (1.26)

Overview



MASS 2100 DI 1.5 is suitable for low flow measurement applications of a variety of liquids and gases.

The sensor offers superior performance in terms of flow accuracy, turn-down ratio and density accuracy. The ease of installation through a "plug & play" mechanical and electrical interface ensures optimum performance and operation.

The sensor delivers true multi-parameter measurements i.e.: Mass flow, volume flow, density, temperature and fraction.

Benefits

- High accuracy better than 0.1 % of mass flow rate
- Large dynamic turn-down ratio better than 500:1, from 65 kg/h to a few g/h
- Densitometer performance available through a density accuracy better than 0.001 g/cm³ with a repeatability better than 0.0002 g/cm³.
- Single continuous tube design, with no internal welds, reductions or flow splitters offers optimal hygiene, safety and CIP cleanability for food and beverage and pharmaceutical applications.
- Market's biggest wall thickness, ensuring optimal life-time and corrosion resistance and high-pressure durability
- Balanced pipe design with little mechanical energy-loss, ensures optimal performance and stability under non-ideal and unstable process conditions (pressure, temperature, density-changes etc.).
- 4-wire Pt1000 temperature measurement ensures optimum accuracy on mass flow, density and fraction flow
- Multi-plug electrical connector and SENSORPROM enables true "plug & play". Installation and commissioning in less than 10 minutes
- Intrinsically safe EEx ia design as standard
- Sensor pipe available in high-quality stainless steel AISI 316L/1.4435 or Hastelloy C22/2.4602 offering optimum corrosion resistance
- Dual-drive pick-up and driver construction facilitate ultra low-weight pipe construction giving the markets' smallest and most stable zero point.
- Rugged and space-saving sensor design in stainless steel matching all environments
- High-pressure program as standard
- The sensor calibration factor is also valid for gas measurement.

Application

In many industries such as the food and beverage or pharmaceutical industry, accurate recipe control means everything. The MASS 2100 DI 1.5 has demonstrated superior performance in numerous applications and field trails relating to accuracy and turn-down ratio. It is today the preferred meter for research and development and mini-plant applications for liquid or gas measurement, where measuring small quantities is important.

The main applications for the MASS 2100 DI 1.5 sensor can be found in:

Chemical industry	Liquid and gas measurement within Miniplant and R & D, dosing of additives and catalysts
Cosmetic industry	Dosing of essence and fragrances
Pharmaceutical industry	High-speed dosing and coating of pills, filling of ampuls/injectors
Food and beverage industry	Dosing of flavourings, colours and additives, density measurement, inline Measurement of liquid or gaseous CO ₂
Automotive industry	Fuel injection nozzle and pump testing, filling of AC units, engine consumption, paint robots, ABS test-beds

Design

The MASS 2100 sensor consists of a single bent tube in a double omega pipe configuration, welded directly to the process connectors at each end.

The sensor is available in 2 material configurations, AISI 316L/1.4404 or Hastelloy C22/2.4602 with 1/4" NPT or 1/4" ISO process connections.

The enclosure is made in stainless steel AISI 316L/1.4404 with a grade of encapsulation of IP65/NEMA 4.

The sensor is available in either a standard version with a maximum liquid temperature of 125 °C (257 °F) or a high-temperature version, with raised electrical connector for 180 °C (356 °F).

The sensor can be installed in horizontal or vertical position. The enclosed single quick release clamp fitting which, along with its compact design and single multi-plug electrical connector, will keep installation costs and time to a minimum as shown below.



Flow Measurement

SITRANS F C

Flow sensor MASS 2100 DI 1.5

Function

The measuring principle is based on the Coriolis effect. See "System information SITRANS F C Coriolis mass flowmeters".

Integration

The sensor can be connected to all MASS 6000 transmitters for remote installation only.

All sensors are delivered with a SENSORPROM containing all information about calibration data, identity and factory pre-programming of transmitter settings

Installation guidelines MASS 2100 DI 1.5 (1/16")

Installation of MASS 2100 sensor

- The optimal installation is horizontal.
If vertical mounting is necessary, upward flow is recommended to facilitate the removal of air bubbles. To remove the air from the sensor the flow speed in the sensor must be at least 1 m/s.
If there are solid particles in the liquid, especially in connection with low flow, it is recommended that the sensor be mounted horizontally with inlet flange uppermost so that particles are more easily flushed out. To ensure that the sensor does not become partially empty, there must be sufficient counter-pressure on the unit min. 0.1 to 0.2 bar (1.45 to 2.9 psi).
- Mount the sensor on a vibration-free wall or steel frame.
- Locate the sensor low in the system in order to avoid an under-pressure in the sensor separating air/gas in the liquid.
- Ensure that the sensor is not emptied of liquid (during normal operation) otherwise incorrect measurement will occur.

Horizontal

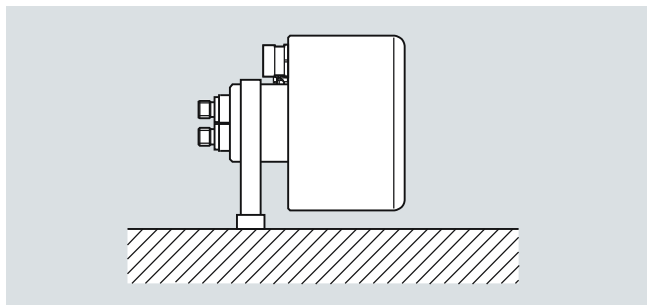

Liquid and gas application

Vertical

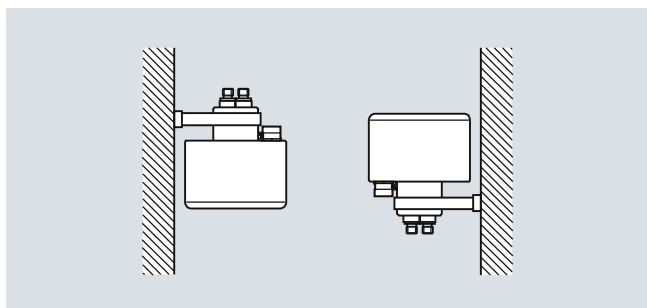

Liquid application (left), gas application (right)

Technical specifications

Inside pipe diameter (sensor consists of one continuous pipe)	1.5 mm (0.06")
Pipe wall thickness	0.25 mm (0.010")
Mass flow measuring range	0 ... 65 kg/h (0 ... 143 lb/h)
Density	0 ... 2.9 g/cm ³ (0 ... 0.10 lb/inch ³)
Fraction e.g.	0 ... 100 °Brix
Temperature	
Standard	-50 ... +125 °C (-58 ... +257 °F)
High-temperature version	-50 ... +180 °C (-58 ... +356 °F)
Liquid pressure measuring pipe¹⁾	
Stainless steel	230 bar (3336 psi) at 20 °C (68 °F)
Hastelloy C22/2.4602	365 bar (5294 psi) at 20 °C (68 °F)
Materials	
Measuring pipe and connection	Stainless steel AISI 316L/1.4435 Hastelloy C22/2.4602
Enclosure and enclosure material²⁾	IP66/NEMA 4 and stainless steel AISI316L/1.4404
Connection thread	
ISO 228/1	G1/4" male
ANSI/ASME B1.20.1	1/4" NPT male
Cable connection	Multiple plug connection to sensor 5 x 2 x 0.35 mm ² twisted and screened in pairs, ext. Ø 12 mm
Ex-version	EEx ia IIC T3-T6, DEMKO 03 ATEX 135252X
Weight approx.	2.6 kg (5.73 lb)

¹⁾ According to DIN 2413, DIN 17457

²⁾ Housing is not rated for pressure containment.

For accuracy specifications see "System information SITRANS F C".

Pressure drop

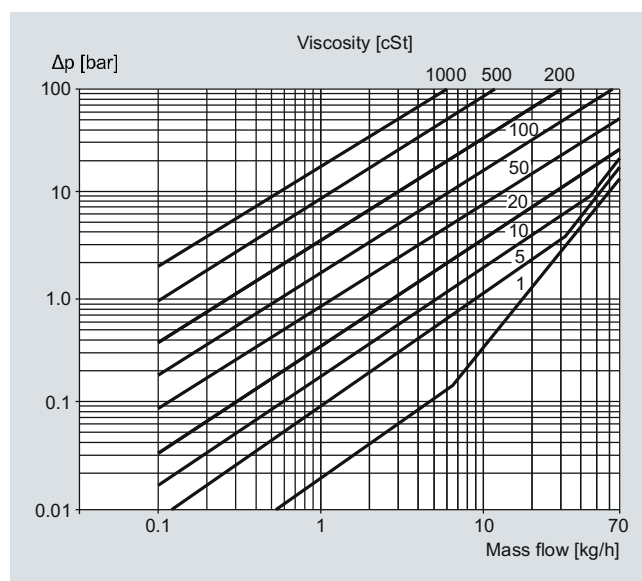

MASS 2100 DI 1.5 (1/16"), pressure drop for density = 1000 kg/m³

Selection and Ordering data	Order No.	Order code
SITRANS F C Flow sensors		
MASS 2100 DI 1.5 (1/16") sensor, without heating jacket¹⁾	7 ME 4 1 0 0 -	
Diameter		
Stainless steel AISI 316L/1.4435		
DI 1.5, max. 125 °C (257 °F)	1 A	
DI 1.5, max. 180 °C (356 °F)	1 B	
Hastelloy C22/2.4602		
DI 1.5, max. 125 °C (257 °F)	2 A	
DI 1.5, max. 180 °C (356 °F)	2 B	
Pressure		
PN 100	D	
PN 230 (AISI 316L/1.4404)	L	
PN 365 (C22/2.4602)	P	
Process connection/flange		
Pipe thread		
G 1/4" male	1 0	
1/4" NPT male	1 1	
Configuration		
Standard		1
Density		2
BRIX/PLATO		3
Fraction (specification required)		9
Transmitter compact mounted on sensor		
No transmitter, sensor and adapter only		A
MASS 6000, Ex d, stainless steel enclosure, 1 current, 1 freq./pulse and 1 relay output, 24 V AC/DC with EEx de [ia/ib] T3-T6 Ex-approval.		B
MASS 6000, IP67, Polyamide enclosure, cable glands M20, 1 current, 1 freq./pulse and 1 relay output, 24 V AC/DC.		C
MASS 6000, IP67, Polyamide enclosure, cable glands M20, 1 current, 1 freq./pulse and 1 relay output, 115/230 V AC 50/60 Hz		D
MASS 6000, IP67, Polyamide enclosure, cable glands 1/2" NPT, 1 current, 1 freq./pulse and 1 relay output, 24 V AC/DC		E
MASS 6000, IP67, Polyamide enclosure, cable glands 1/2" NPT, 1 current, 1 freq./pulse and 1 relay output, 115/230 V AC 50/60 Hz, 1/2" NPT		F
Cable		
No cable		A
5 m (16.4 ft) cable		B
10 m (32.8 ft) cable		C
25 m (82 ft) cable		D
50 m (164 ft) cable		E
75 m (246 ft) cable		F
150 m (492 ft) cable		G
Calibration		
Standard calibration 3 flow x 2 points		1
Standard calibration matched pair 3 flow x 2 points		2
Accredited calibration matched pair 5 flow x 2 points (DANAK)		3
Extended calibration customer-specified select Y60, Y61, Y62 or Y63 (see additional information)		8

¹⁾ Not possible to order DI 1.5 sensor with heat jacket.

Selection and Ordering data	Order code
Additional information	
Please add "-Z" to Order No. and specify Order code(s) and plain text.	
Pressure testing certificate PED: 97/23/EC	C11
Material certificate EN 10204-3.1	C12
Welding certificate NDT-Penetrant: ISO 3452	C13
Factory certificate according to EN 10204 2.2	C14
Factory certificate according to EN 10204 2.1	C15
Tag name plate, stainless steel	Y17
Tag name plate, plastic	Y18
Customer-specific transmitter setup	Y20
Customer-specified, matched pair (5 x 2)	Y60
Customer-specified calibration (5 x 2)	Y61
Customer-specified, matched pair (10 x 1)	Y62
Customer-specified calibration (10 x 1)	Y63
Cleaned for oil and grease	Y80
Special version	Y99

Operating instructions for SITRANS F C MASS 2100 DI 1.5

Description	Order No.
• English	A5E03089952

This device is shipped with a Quick Start guide and a CD containing further SITRANS F literature.

All literature is also available for free at:
<http://www.siemens.com/flowdocumentation>

Please also see www.siemens.com/SITRANSFordering for practical examples of ordering

Accessories

Description	Order No.
Cable with multiple plug	
5 m (16.4 ft)	FDK-083H3015
Standard blue cable between MASS 6000 and MASS 2100,	10 m (32.8 ft) FDK-083H3016
5 x 2 x 0.34 mm ² twisted and screened in pairs.	25 m (82 ft) FDK-083H3017
Temperature range -20 °C ... +110 °C (-4 °F ... +230 °F)	50 m (164 ft) FDK-083H3018
	75 m (246 ft) FDK-083H3054
	150 m (492 ft) FDK-083H3055

Spare parts

Description	Order No.
Multiple plug for cable mounting	FDK-083H5056
2 kB SENSORPROM unit (Sensor Serial No. and Order No. must be specified by ordering)	FDK-083H4410
Bracket	A5E02590427

Flow Measurement SITRANS F C

Flow sensor MASS 2100 DI 1.5

Dimensional drawings

MASS 2100 DI 1.5 (1/16")

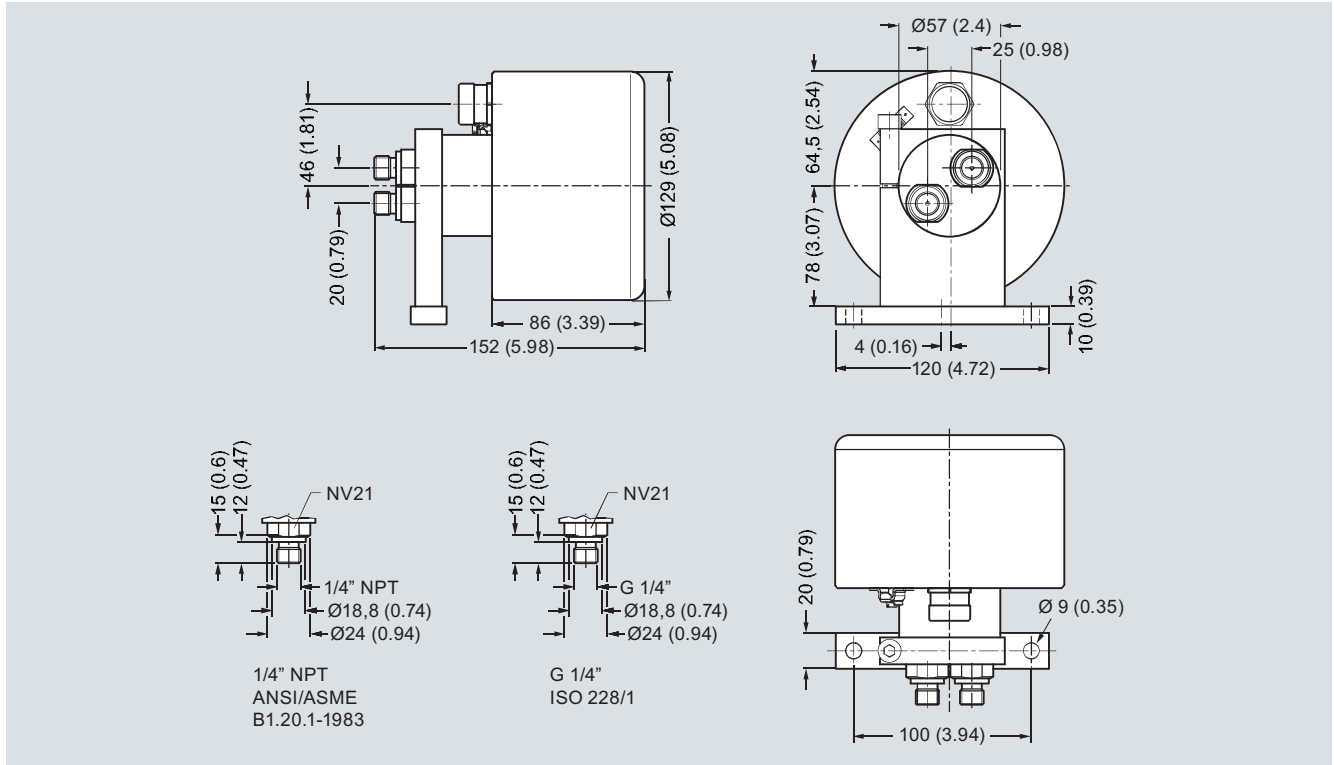

Dimensions in mm (inch)

MASS 2100 DI 1.5 High-temperature version to 180 °C (356 °F)

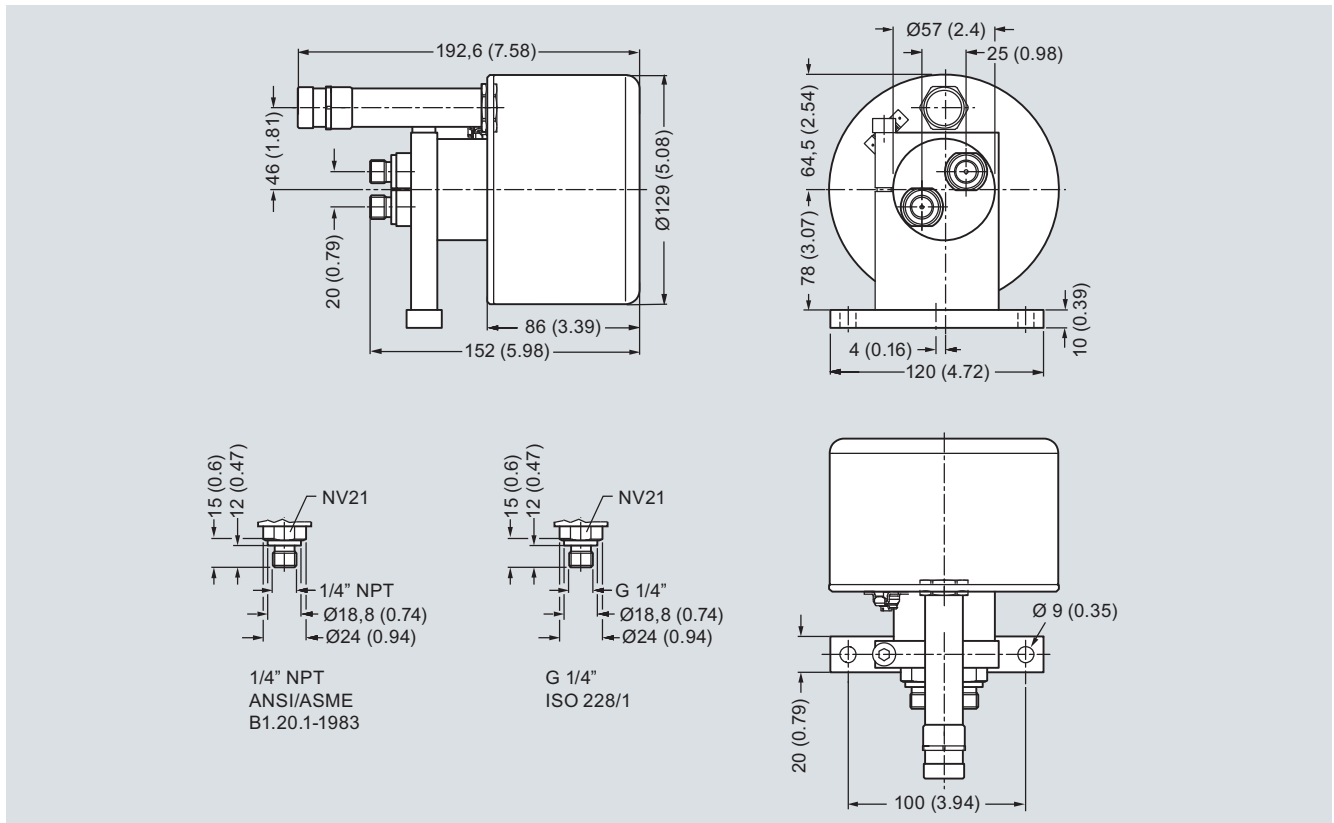

Dimensions in mm (inch)

Overview

SITRANS FC300 is a compact Coriolis mass sensor suitable for flow measurement of a variety of liquids and gases.

The sensor offers superior performance in terms of flow accuracy, turn-down ratio and density accuracy. The ease of installation through a „plug & play“ interface ensures optimum performance and operation.

A new designed encapsulation in stainless steel with a surprisingly low weight of only 3.5 kg (7.7 lb), ensures a rigid and robust sensor performance for a wide range of applications.

Benefits

- High accuracy better than 0.1 % of mass flow rate
- Large dynamic turn-down ratio better than 500:1
- Densitometer performance available through a density accuracy better than 0.001 g/cm³ (0.000036 lb/inch³) with a repeatability better than 0.0002 g/cm³ (0.0000072 lb/inch³)
- One tube without internal welds, reductions or flow splitters offers optimal hygiene, safety and CIP cleanability for food and beverage and pharmaceutical applications
- Larger wall thickness, ensures optimal life-time and corrosion resistance and high-pressure durability
- Balanced pipe design with little mechanical energy loss, ensures optimal performance and stability under non-ideal and unstable process conditions (pressure, temperature, density-changes etc.).
- 4-wire Pt1000 temperature measurement ensures optimum accuracy on mass flow, density and fraction flow
- Multi-plug electrical connector and SENSORPROM enable true „plug & play“. Installation and commissioning in less than 10 minutes.
- Intrinsically safe Ex design ia IIC as standard
- Sensor pipe available in high-quality stainless steel AISI 316L/1.4435 or Hastelloy C22/2.4602 offering optimum corrosion resistance.
- Rugged and space-saving sensor design in stainless steel matching all applications.
- High-pressure program as standard
- The sensor calibration factor is also valid for gas measurement.

Application

The industry today has an increasing demand for mass flowmeters with a reduced physical size without loss of performance. The meters must be suitable for installation in traditional process industry environment as well as OEM equipment for instance within automotive or appliance industry. Independent of industry application the meter must deliver accurate and reliable measurements. The new and versatile design of the FC300 offers this flexibility.

The main applications for the SITRANS FC300 DN 4 can be found in:

Chemical industry	Liquid and gas measurement in normal as well as corrosive environments
Cosmetic industry	Dosing of essence and fragrances
Pharmaceutical industry	High-speed dosing and coating of pills, filling of ampuls/injectors
Food and beverage industry	Filling, dosing of flavorings, colors and additives, inline density measurement Measurement and dosing of liquid or gaseous CO ₂
Automotive industry	Fuel injection nozzle and pump testing, filling of AC units, engine consumption, paint robots, ABS test-beds

Design

The FC300 sensor consists of a single tube bent in double omega pipe geometry, welded directly to the process connectors at each end. The sensor is available in 2 material configurations, AISI 316L/1.4404 or Hastelloy C22/2.4602 with ¼"-NPT or G¼"-ISO process connections.

The enclosure is made of stainless steel AISI 316L/1.4409 with a grade of encapsulation of IP66/NEMA4. The enclosure has a very robust design and with an overall size of 130 x 200 x 60 mm (5.12" x 7.87" x 2.36") the sensor is very compact and requires only little installation space.

The sensor can be delivered in a standard version with a maximum liquid temperature of 115 °C (239 °F) or a high-temperature version, with raised electrical connector for 180 °C (356 °F).

The sensor can be installed in horizontal or vertical position. The sensor can be mounted directly on any given plane surface or if desired with the enclosed quick release clamp fitting which, along with its compact design and multi-plug electrical connector, will keep installation costs and time to a minimum.

Function

The measuring principle is based on the Coriolis effect. See "System information SITRANS F C Coriolis mass flowmeters".

Integration

The sensor can be connected to all MASS 6000 transmitters for remote installation only.

All sensors are delivered with a SENSORPROM containing all information about calibration data, identity and factory pre-programming of transmitter settings

Flow Measurement

SITRANS F C

Flow sensor SITRANS FC300

Installation guidelines for SITRANS FC300 sensor

Horizontal installation as shown in figure A is recommended with gas or liquid applications.

This installation is also recommended when the flow velocity is low (< 1 m/s) or the liquid contains solid particles or air bubbles.

Vertical installation as shown in figure B can be used for liquid or gas applications.

For liquid applications upwards flow is recommended to facilitate the removal of air bubbles and to avoid partly emptying of the sensor.

For gas applications we recommend to place the flow inlet on the sensor high and the outlet low to remove impurities and oil films.

- To ensure that the sensor does not become partly empty, there must be a sufficient counter-pressure on the unit min. 0.1 to 0.2 bar (1.5 to 2.9 psi).
- Mount the sensor on a vibration-free and plane wall or steel frame.
- Locate the sensor low in the system in order to avoid under-pressure in the sensor separating air/gas in the liquid.
- Ensure that the sensor is not emptied of liquid (during normal operation) otherwise incorrect measurement will occur.

Horizontal mounting (recommended) (fig. A)

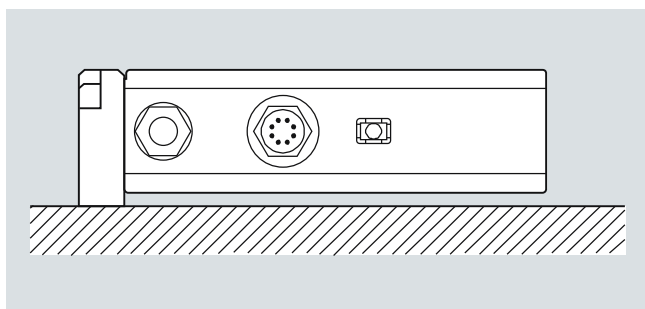

Liquid or gas (low to high flow)

Vertical mounting (fig. B)

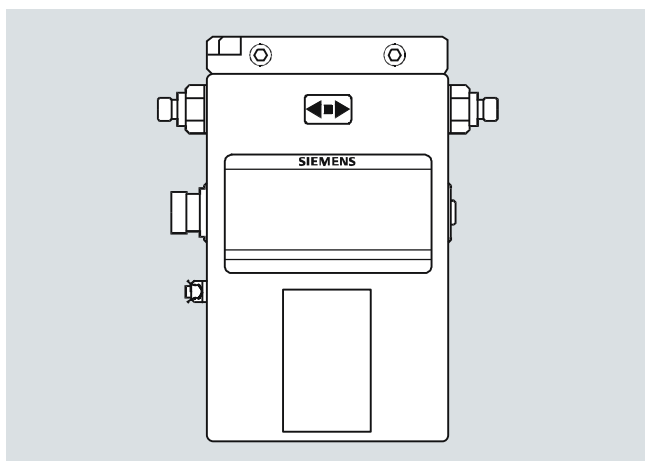

Liquid or gas (medium to high flow)

Technical specifications

Sensor size	DN 4 (1/6")
Mass flow	
Measuring range	0 ... 350 kg/h (0 ... 772 lb/h)
Accuracy, mass flow	0.1 % of rate
Repeatability	0.05 of rate
Max. zero point error	0.010 kg/h (0.022 lb/h)
Density	
Density range	0 ... 2.9 g/cm ³ (0 ... 0.105 lb/inch ³)
Density error	0.0015 g/cm ³ (0.000036 lb/inch ³)
Repeatability error	0.0002 g/cm ³ (0.0000072 lb/inch ³)
Temperature	
Standard	-40 ... +115 °C (-40 ... +239 °F)
High-temperature version	-40 ... +180 °C (-40 ... +356 °F)
Temperature error	0.5 °C (0.9 °F)
BRIX	
Measuring range	0 ... 100 BRIX
Brix error	0.3 BRIX
Inside pipe diameter	
Stainless steel version	3.5 mm (0.14")
Hastelloy version	3.0 mm (0.12")
Pipe wall thickness	
Stainless steel version	0.25 mm (0.0098")
Hastelloy version	0.5 mm (0.0196")
Liquid pressure measuring pipe¹⁾	
Stainless steel	130 bar (1885 psi) at 20 °C (68 °F)
Hastelloy C22/2.4602	410 bar (5945 psi) at 20 °C (68 °F)
Materials	Stainless steel AISI 316L/1.4435
Measuring pipe and connection	Hastelloy C22/2.4602
Enclosure²⁾	
Material	Stainless steel AISI 316L/1.4404
Enclosure grade	IP67/NEMA4
Connection thread	
ISO 228/1	G1/4" male
ANSI/ASME B1.20.1	1/4" NPT male
Ex approval	
	EEx ia IIC T3-T6 05ATEX138072X UL/CSA
Weight	3.5 kg (7.7 lb)
Dimensions	135 x 205 x 58 mm (5.31" x 8.07" x 2.28")

¹⁾ According to DIN 2413, DIN 17457

²⁾ Housing is not rated for pressure containment.

Selection and Ordering data	Order No.	Order code
SITRANS F C Flow sensors		
SITRANS FC300 DN 4 (1/6") sensor, without heating jacket¹⁾	7 ME 4 4 0 0 -	
Pipe material and temperature		
Stainless steel AISI 316L/1.4435		
115 °C (239 °F)	1 G	
180 °C (356 °F)	1 H	
Hastelloy C22/2.4602		
115 °C (239 °F)	2 G	
180 °C (356 °F)	2 H	
Pressure		
PN 100	D	
PN 130 (316L)	G	
PN 410 (C22)	Q	
Process connection		
Pipe thread		
G 1/4" male	1 0	
1/4" NPT male	1 1	
Configuration		
Standard		1
Density		2
BRIX/PLATO		3
Fraction (specification required)		9
Transmitter compact mounted on sensor		
No transmitter, sensor and adapter only		A
MASS 6000, Ex d, stainless steel enclosure, 1 current, 1 freq./pulse and 1 relay output, 24 V AC/DC with EEx de [ia/ib] T3 -T6 Ex-approval		B
MASS 6000, IP67, Polyamide enclosure, cable glands M20, 1 current, 1 freq./pulse and 1 relay output, 24 V AC/DC		C
MASS 6000, IP67, Polyamide enclosure, cable glands M20, 1 current, 1 freq./pulse and 1 relay output, 115/230 V AC 50/60 Hz		D
MASS 6000, IP67, Polyamide enclosure, cable glands 1/2" NPT, 1 current, 1 freq./pulse and 1 relay output, 24 V AC/DC		E
MASS 6000, IP67, Polyamide enclosure, cable glands 1/2" NPT, 1 current, 1 freq./pulse and 1 relay output, 115/230 V AC 50/60 Hz, 1/2" NPT		F
Cable		
No cable		A
5 m (16.4 ft) cable		B
10 m (32.8 ft) cable		C
25 m (82 ft) cable		D
50 m (164 ft) cable		E
75 m (246 ft) cable		F
150 m (492 ft) cable		G
Calibration		
Standard calibration 3 flow x 2 points		1
Standard calibration matched pair 3 flow x 2 points		2
Accredited calibration matched pair 5 flow x 2 points (DANAK)		3
Extended calibration customer-specified select Y60, Y61, Y62 or Y63 (see additional information)		8

¹⁾ Not possible to order DN 4 sensor with heating jacket

Selection and Ordering data	Order code
Additional information	
Please add "-Z" to Order No. and specify Order code(s) and plain text.	
Pressure testing certificate PED: 97/23/EC	C11
Material certificate EN 10204-3.1	C12
Welding certificate NDT-Penetrant: ISO 3452	C13
Factory certificate according to EN 10204 2.2	C14
Factory certificate according to EN 10204 2.1	C15
Tag name plate, stainless steel	Y17
Tag name plate, plastic	Y18
Customer-specific transmitter setup	Y20
Customer-specified, matched pair (5 x 2)	Y60
Customer-specified calibration (5 x 2)	Y61
Customer-specified, matched pair (10 x 1)	Y62
Customer-specified calibration (10 x 1)	Y63
Cleaned for oil and grease	Y80
Special version	Y99

Operating instructions for SITRANS F C FC300

Description	Order No.
• English	A5E00698213
• German	A5E00728101
• Spanish	A5E00746629
• French	A5E00746625

This device is shipped with a Quick Start guide and a CD containing further SITRANS F literature.

All literature is also available for free at:
<http://www.siemens.com/flowdocumentation>

Accessories

Description	Order No.
Cable with multiple plug	
Standard blue cable between MASS 6000 and MASS 2100, 5 x 2 x 0.34 mm ² twisted and screened in pairs.	5 m (16.4 ft) FDK-083H3015
	10 m (32.8 ft) FDK-083H3016
	25 m (82 ft) FDK-083H3017
Temperature range -20 °C ... +110 °C (-4 °F ... +230 °F)	50 m (164 ft) FDK-083H3018
	75 m (246 ft) FDK-083H3054
	150 m (492 ft) FDK-083H3055

Spare parts

Description	Order No.
Multiple plug for cable mounting	FDK-083H5056
2 kB SENSORPROM unit (Sensor Serial No. and Order No. must be specified by ordering)	FDK-083H4410
Bracket	A5E02590439
Demo suitcase including MASS 6000 and HART module	A5E00789737

Flow Measurement SITRANS F C

Flow sensor SITRANS FC300

Characteristic curves

Pressure drop

4

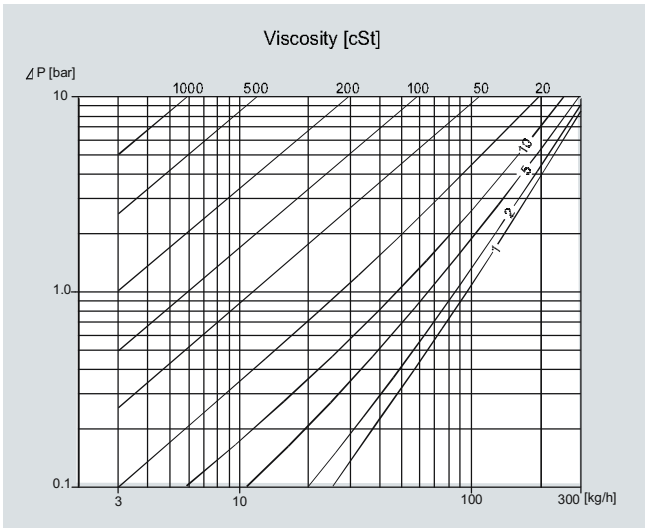
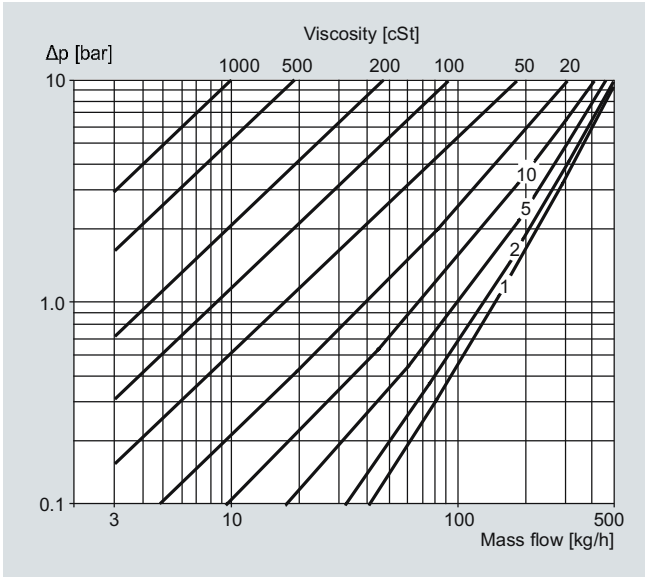

Dimensional drawings

SITRANS FC300 DN 4

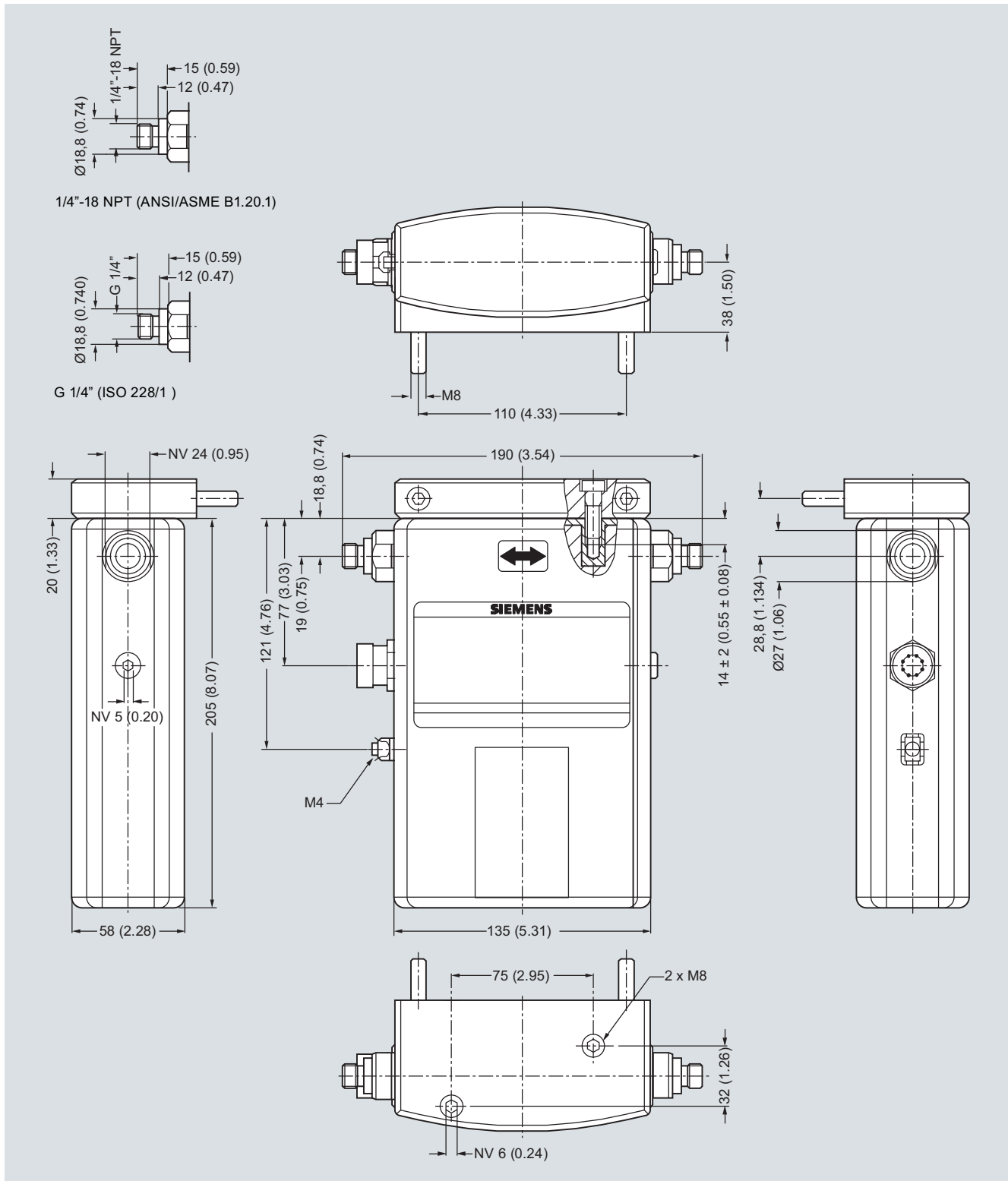

SITRANS FC300, dimensions in mm (inch)

Flow Measurement

SITRANS F C

Flow sensor MASS 2100 DI 3 to DI 40

Overview



MASS 2100 DI 3 to DI 40 is suitable for accurate mass flow measurement of a variety of liquids and gases.

The sensor offers superior performance in terms of flow accuracy, turn-down ratio and density accuracy. The ease of installation through a "plug & play" mechanical and electrical interface ensures optimum performance and operation.

The sensor delivers true multi-parameter measurements i.e.: Mass flow, volume flow, density, temperature and fraction.

Benefits

- High accuracy better than 0.1 % of mass flow rate
- Large dynamic turn-down ratio better than 500:1
- Densitometer performance available through a density accuracy better than 0.0005 g/cm³ with a repeatability better than 0.0001 g/cm³
- Single continuous tube design, with no internal welds, reductions or flow splitters offers optimal hygiene, safety and CIP cleanability for food and beverage and pharmaceutical applications.
- Markets' biggest wall thickness, ensuring optimal life-time and corrosion resistance and high-pressure durability
- Full bore design provides lower pressure loss due to same internal diameter throughout the entire sensor.
- Balanced pipe design with little mechanical energy loss, ensures optimal performance and stability under non-ideal and unstable process conditions (pressure, temperature, density changes etc.).
- 4-wire Pt1000 temperature measurement ensures optimum accuracy on mass flow, density and fraction flow.
- Multi-plug electrical connector and SENSORPROM enables true "plug & play". Installation and commissioning in less than 10 minutes.
- Intrinsically safe Ex design ia IIC as standard, making service in hazardous area possible without having to demount the sensor if a compact Ex d transmitter needs service.
- Sensor pipe available in high-quality stainless steel AISI 316L/1.4435 or Hastelloy C22/2.4602 offering optimum corrosion resistance
- Centre-block design decouples process noise from the environment such as vibrations, pulsations, pressure shocks etc. making installation flexible and versatile.
- Rugged and space-saving sensor design in stainless steel matching all environments
- High-pressure program as standard
- The sensor calibration factor is also valid for gas measurement.
- Uniform sensor interface matching all transmitter versions at the same time whether it is compact IP67/NEMA 4X, compact Ex d or remote installation, one sensor fits all.

Application

Coriolis mass flowmeters are suitable for measuring all liquids and gases. The measurement is independent of changes in process conditions/parameters such as temperature, density, pressure, viscosity, conductivity and flow profile.

Due to this versatility the meter is easy to install and the Coriolis flowmeter is recognized for its high accuracy in a wide turn-down ratio which is a paramount in many applications.

The main applications of the Coriolis flowmeter can be found in all industries, such as:

Chemical and pharma	Detergents, bulk chemicals, pharmaceuticals, acids, alkalis
Food and beverage	Dairy products, beer, wine, soft-drinks, BRIX/PLATO, fruit juices and pulps, bottling, CO ₂ dosing, CIP-liquids
Automotive	Fuel injection nozzle and pump testing, filling of AC units, engine consumption, paint robots
Oil and gas	Filling of gas bottles, furnace control, CNG-dispensers, test separators, LPG
Water and waste water	Dosing of chemicals for water treatment

The wide variety of combinations and versions from the modular system means that ideal adaptation is possible to each measuring task.

Design

The MASS 2100 sensor consists of a single bent tube in a double bent pipe configuration, welded directly to the process connectors at each end.

The centre-block is brazed onto the sensor pipes from the outside acting as a mechanical low pass filter.

The sensor is available in 2 material configurations, AISI 316L/1.4404 or Hastelloy C22/2.4602 with a wide variety of process connections.

The enclosure is made in stainless steel AISI 316/1.4404 with a grade of encapsulation of IP66/NEMA 4.

The sensor is as standard EEx ia approved, intrinsically safe.

The sensor can be installed in horizontal or vertical position. In horizontal position the sensor is self draining.

Heating Jacket: All the sensors MASS 2100, DI 3 to DI 40, can optionally be equipped with a heating coil to avoid solidification of sensitive fluids during down-time or period between discontinuing processes. This feature gives the user an alternative to the costly electrical heating normally used, as it gives the freedom to choose either hot water, superheated steam or hot oil, to maintain a constant temperature inside the sensor.

Flow Measurement SITRANS F C

Flow sensor MASS 2100 DI 3 to DI 40

Function

The measuring principle is based on the Coriolis effect. See "System information SITRANS F C Coriolis mass flowmeters".

Integration

The sensor can be connected to all MASS 6000 transmitters for compact as well as remote installation.

All sensors are delivered with a SENSORPROM containing all information about calibration data, identity and factory pre-programming of transmitter settings.

Installation guidelines MASS 2100 DI 3 ... DI 40 (1/8" ... 1 1/2")

Installation of sensor

If the liquid is volatile or contains solid particles, vertical mounting is not recommended.

	Liquid	Gas
Horizontal		
Vertical		

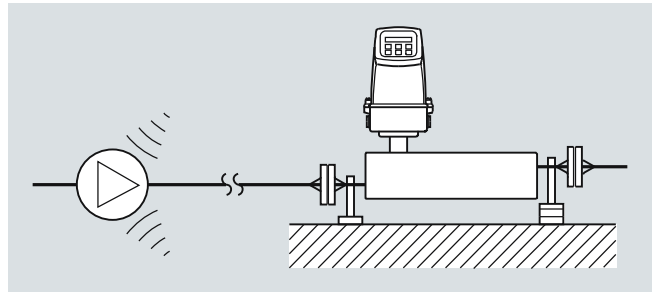

Vibration

Always locate the flowmeter as far away as possible from components that generate mechanical vibration in the piping.

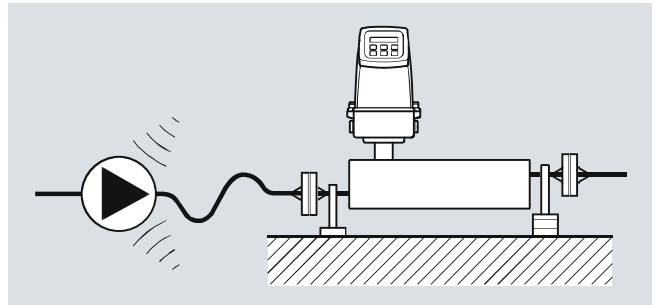

Cross talk

Cross talk between sensors mounted close to each other may disturb the measurement. To avoid cross talk never mount more than one meter on each frame and mount flexible hose connections between the sensors as shown.

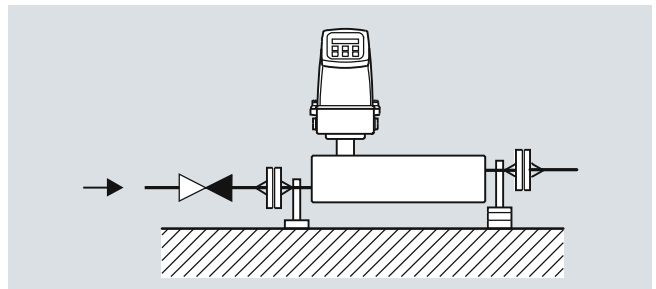

Zero point adjustment

To facilitate zero point adjustment a shut-off valve should always be mounted in connection with the sensor as a proper zero point setting is essential for a good accuracy.

Flow Measurement

SITRANS F C

Flow sensor MASS 2100 DI 3 to DI 40

Technical specifications

Versions (mm (inch))		DI 3 (1/8)	DI 6 (¼)	DI 15 (5/8)	DI 25 (1)	DI 40 (1½)
Inside pipe diameter (sensor consists of one continuous pipe)	mm (inch)	3.0 (0.12)	6.0 (0.24)	14.0 (0.55)	29.7 (1.17)	43.1 (1.70)
Pipe wall thickness	mm (inch)	0.5 (0.02)	1.0 (0.04)	1.0 (0.04)	2.0 (0.08)	2.6 (0.10)
Mass flow measuring range	kg/h (lb/h)	0 ... 250 (0 ... 550)	0 ... 1000 (0 ... 2200)	0 ... 5600 (0 ... 12345)	0 ... 25000 (0 ... 55100)	0 ... 52000 (0 ... 114600)
Density	g/cm ³ (lb/inch ³)	0 ... 2.9 (0 ... 0.10)				
Fraction e.g.	°Brix	0 ... 100				
Temperature						
Standard	°C (°F)	-50 ... +180 °C (-58 ... +356 °F)				
Liquid pressure measuring pipe¹⁾						
Stainless steel	bar (psi)	230 (3336)	265 (3844)	130 (1885)	110 (1595)	105 (1523)
Hastelloy C22/2.4602	bar (psi)	350 (5076)	410 (5946)	200 (2900)	185 (2683)	not available
Materials						
Measuring pipe, flange and thread connection		Stainless steel AISI 316L/1.4435 Hastelloy C22/2.4602 not available				
Enclosure and enclosure material		IP65 (NEMA 4) and stainless steel AISI 316L/1.4404, The housing is not rated for pressure containment				
Process connections²⁾						
Flange						
EN 1092-1, PN 40			DN 10	DN 15	DN 25	DN 40
ANSI B16.5, Class 150			½"	½"	1"	1½"
ANSI B16.5, Class 600 (Class 300)			½"	½"	1"	1½"
Dairy screwed connection (PN 16/25/40)³⁾						
DIN 11851			DN 10	DN 15	DN 32	DN 40
ISO 2853/BS 4825 part 4 (SS3351)			25 mm	25 mm	38 mm	51 mm
Dairy clamp connection (PN 16)³⁾						
ISO 2852/BS 4825 part 3 (SMS3016)			25 mm	25 mm	38 mm	51 mm
Thread						
ISO 228/1, PN 100		G¼" female	G¼" male	G½" male	G1" male	G2" male
ANSI/ASME B1.20.1, PN 100		¼" NPT female	¼" NPT male	½" NPT male	1" NPT male	2" NPT male
Cable connection		Multiple plug connection to sensor 5 x 2 x 0.35 mm ² twisted and screened in pairs, ext. Ø 12 mm				
Ex-version		EEx ia IIC T3-T6, DEMKO 03 ATEX 135252X				
Weight approx.	kg (lb)	4 (8.8)	8 (17.6)	12 (26.5)	48 (105.8)	70 (154.5)

¹⁾ Max. at 20 °C (68 °F), DIN 2413, DIN 17457

²⁾ Other connections to order, see "Selection and Ordering data"

³⁾ Material, AISI 316/1.4401 or corresponding

For accuracy specification see "System information SITRANS F C".

Flow sensor MASS 2100 DI 3 to DI 40

Pressure drop

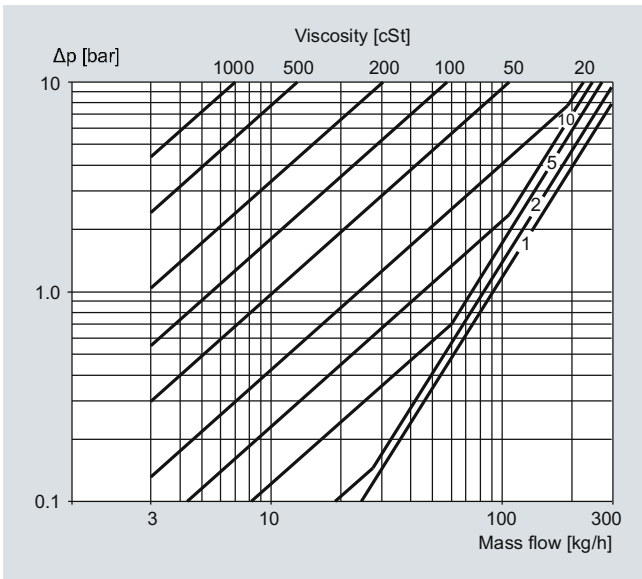

MASS 2100 DI 3 (1/8"), pressure drop for density = 1000 kg/m³

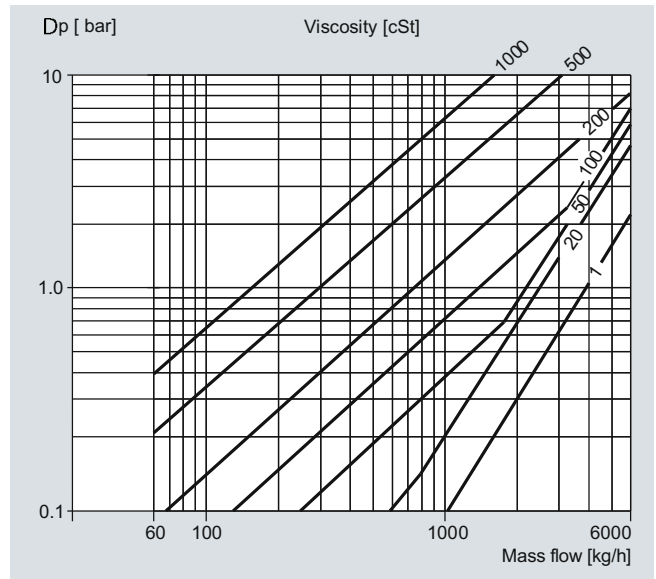

MASS 2100 DI 15 (1/2"), pressure drop for density = 1000 kg/m³

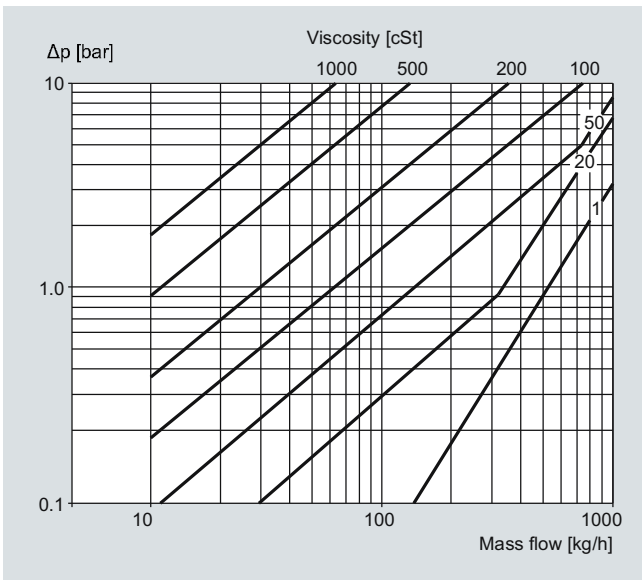

MASS 2100 DI 6 (1/4"), pressure drop for density = 1000 kg/m³

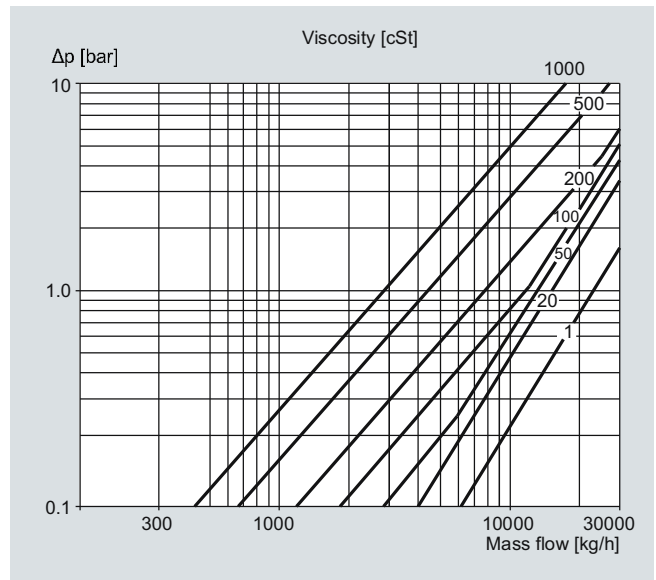

MASS 2100 DI 25 (1"), pressure drop for density = 1000 kg/m³

4

Flow Measurement SITRANS F C

Flow sensor MASS 2100 DI 3 to DI 40

4

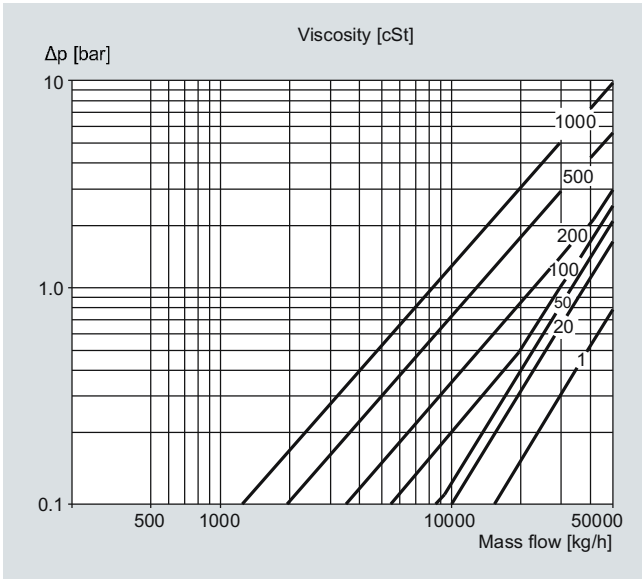

MASS 2100 DI 40 (1½"), pressure drop for density = 1000 kg/m³

Pressure/temperature curves

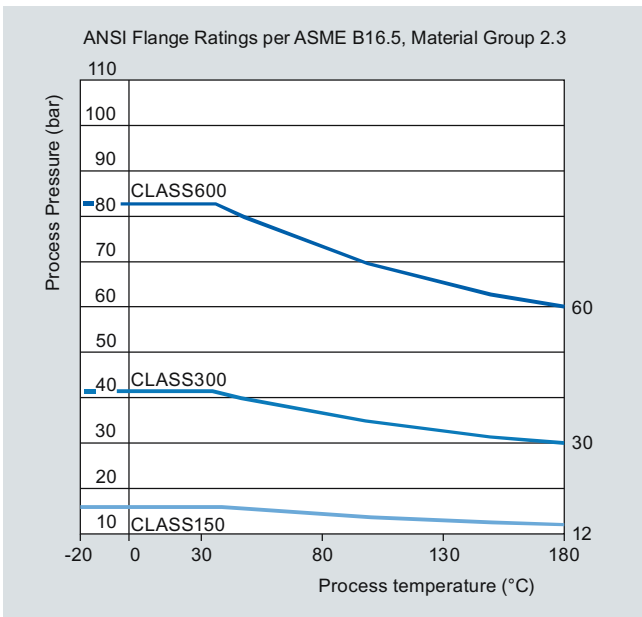

ASME flanges B16.5 stainless steel

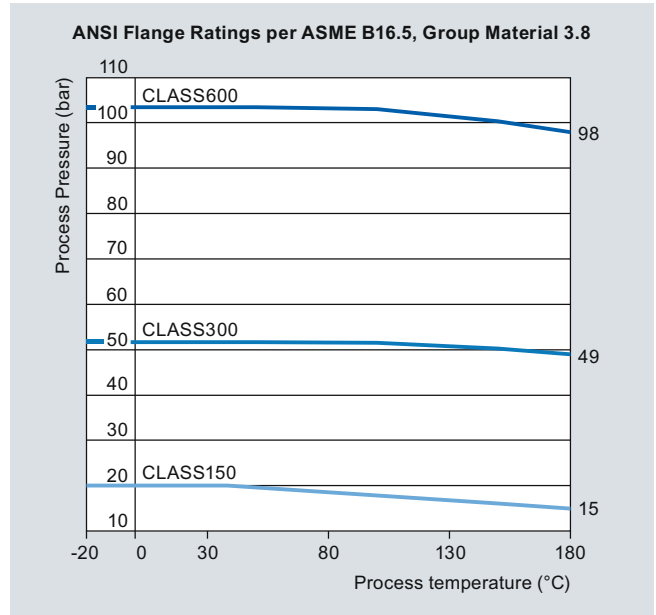

ASME flanges B16.5 Hastelloy C22/2.4602

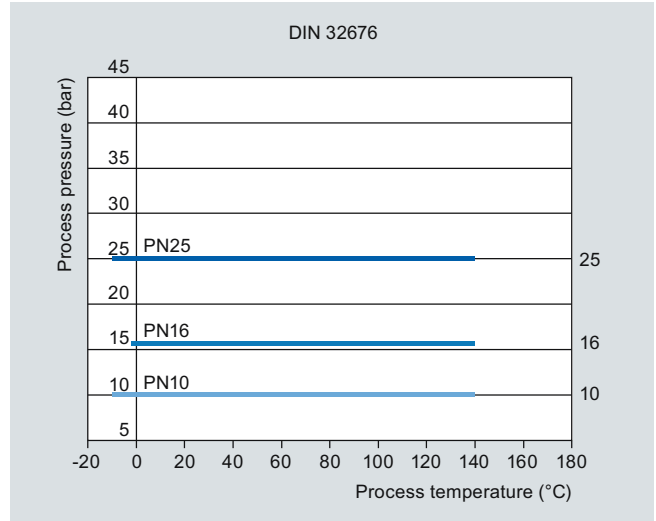

DIN 32676 flanges stainless steel (PN 10 ... PN 25)

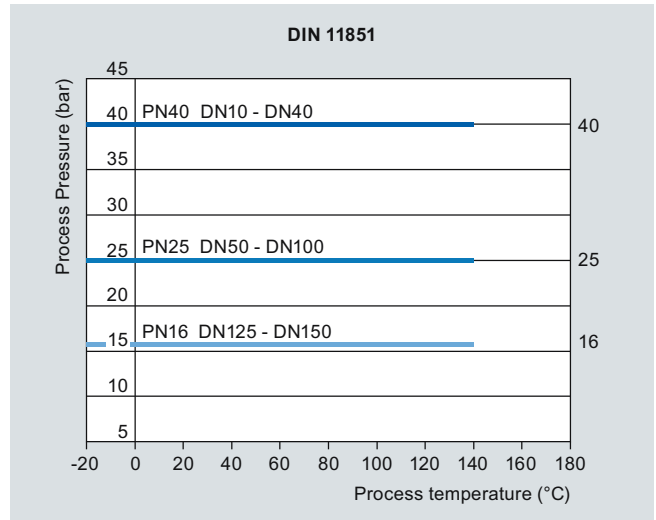

DIN 11851 flanges stainless steel (PN 25 ... PN 40)

Flow sensor MASS 2100 DI 3 to DI 40

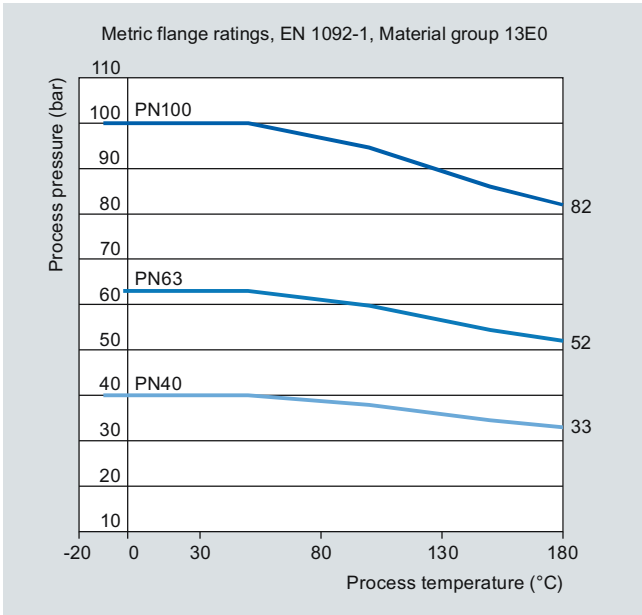

EN 1092 flanges stainless steel (PN 40 ... PN 100)

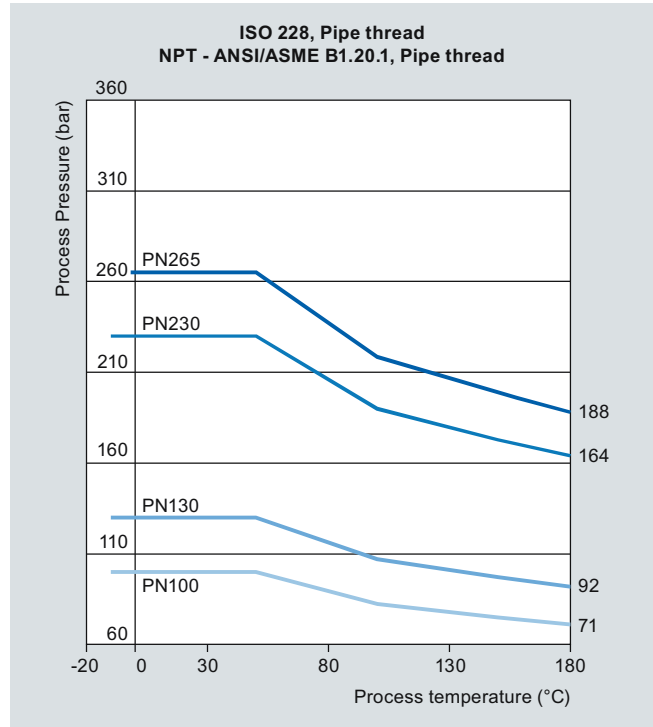

ISO 228 and NPT pipe thread stainless steel (PN 100 ... PN 265)

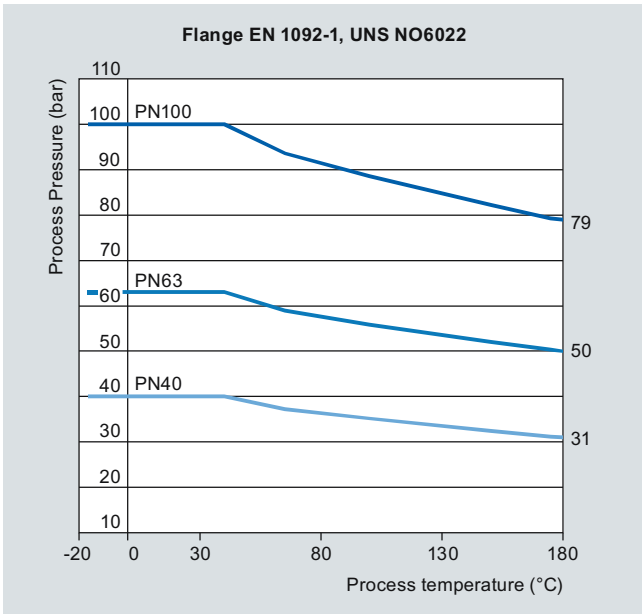

EN 1092 flanges Hastelloy C22/2.4602 (PN 40 ... PN 100)

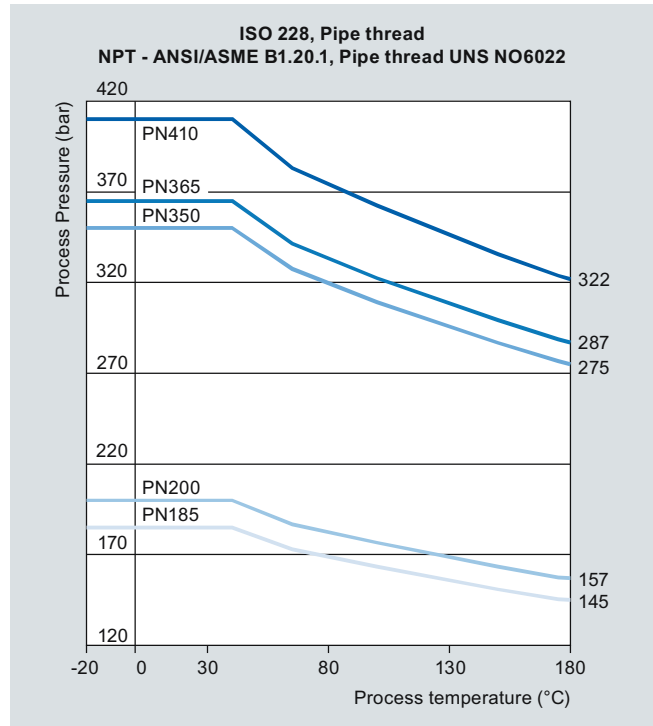

ISO 218 and NPT pipe thread stainless steel (PN 185 ... PN 410)

For further information on the PED standard and requirements, see page 10/9.

Flow Measurement

SITRANS F C

Flow sensor MASS 2100 DI 3 to DI 40

Selection and Ordering data

Selection and Ordering data	Order No.	Order code
SITRANS F C sensors		
MASS 2100 without heating jacket	7 ME 4 1 0 0 -	
MASS 2100 heated, DN 15 connection	7 ME 4 2 0 0 -	
MASS 2100 heated, ½ inch, ANSI B16.5 connection	7 ME 4 2 1 0 -	
Diameter		
Stainless steel AISI 316L/1.4435 DI 3 (PN 100/PN 230)	1 C	
DI 6	1 D	
DI 15	1 E	
DI 25	1 F	
DI 40	1 G	
Hastelloy C22/2.4602 DI 3 (PN 100/PN 350)	2 C	
DI 6	2 D	
DI 15	2 E	
DI 25	2 F	
Pressure		
PN 16 (DI 6, DI 15, DI 25 and DI 40)	A	
PN 25 (DI 6, DI 15, DI 25 and DI 40)	B	
PN 40 (DI 6, DI 15, DI 25 and DI 40)	C	
PN 100 (DI 3, DI 6, DI 15, DI 25 and DI 40)	D	
PN 105 (DI 40, 2", AISI 316L/1.4404)	E	
PN 110 (DI 25, 1", AISI 316L/1.4404)	F	
PN 130 (DI 15, ½", AISI 316L/1.4404)	G	
PN 185 (DI 25, 1", Hastelloy C22/2.4602)	J	
PN 200 (DI 15, ½", Hastelloy C22/2.4602)	K	
PN 230 (DI 3, ¼", AISI 316L/1.4404)	L	
PN 265 (DI 6, ¼", AISI 316L/1.4404)	M	
PN 350 (DI 3, ¼", Hastelloy C22/2.4602)	N	
PN 410 (DI 6, ¼", Hastelloy C22/2.4602)	Q	
Class 150 (DI 6, DI 15, DI 25 and DI 40)	R	
Class 600 (DI 6, DI 15, DI 25 and DI 40)	S	
Process connection/flange		
Pipe thread		
G ¼"	1 0	
¼" NPT	1 1	
G ½"	1 2	
½" NPT	1 3	
G 1	1 4	
1" NPT	1 5	
G 2"	1 6	
2" NPT	1 7	
Flange EN1092-1 Form B		
DN 10 (PN 40/PN 100)	2 0	
DN 15 (PN 40/PN 100)	2 1	
DN 25 (PN 40/PN 100)	2 2	
DN 40 (PN 40/PN 100)	2 3	
DN 50 (PN 40/PN 100)	2 4	
Flange ASME/ANSI B 16.5		
½" (class 150/class 600)	3 0	
¾" (class 150/class 600)	3 1	
1" (class 150/class 600)	3 2	
1 ½" (class 150/class 600)	3 3	
2" (class 150/class 600)	3 4	

Please also see www.siemens.com/SITRANSFordering for practical examples of ordering

Selection and Ordering data

Selection and Ordering data	Order No.	Order code
SITRANS F C sensors		
MASS 2100 without heating jacket	7 ME 4 1 0 0 -	
MASS 2100 heated, DN 15 connection	7 ME 4 2 0 0 -	
MASS 2100 heated, ½ inch, ANSI B16.5 connection	7 ME 4 2 1 0 -	
Dairy screwed connection DIN 11851		
DN 10 (PN 40)	4 0	
DN 15 (PN 40)	4 1	
DN 25 (PN 40)	4 2	
DN 32 (PN 40)	4 3	
DN 40 (PN 25)	4 4	
DN 50 (PN 25)	4 5	
DN 65 (PN 25)	4 6	
Dairy clamp connection ISO 2852 (DIN 32676)		
Cone down the sensor in order to obtain self-drainage with connectors ISO 2852		
25 mm (PN 16)	5 0	
38 mm (PN 16)	5 1	
51 mm (PN 16)	5 2	
Dairy screwed connection ISO 2853		
25 mm (PN 16)	6 0	
38 mm (PN 16)	6 1	
51 mm (PN 16)	6 2	
Configuration/calibration type		
Standard	1	
Density	2	
BRIX/PLATO	3	
Fraction (specification required)	9	N O Y
Transmitter compact mounted on sensor		
No transmitter, sensor and adapter only	A	
MASS 6000, Ex d, stainless steel enclosure, 1 current, 1 freq./pulse and 1 relay output, 24 V AC/DC with EEx de [ia/ib] T3 -T6 Ex-approval	B	
MASS 6000, IP67, Polyamide enclosure, cable glands M20, 1 current, 1 freq./pulse and 1 relay output, 24 V AC/DC	C	
MASS 6000, IP67, Polyamide enclosure, cable glands M20, 1 current, 1 freq./pulse and 1 relay output, 115/230 V AC 50/60 Hz	D	
MASS 6000, IP67, Polyamide enclosure, cable glands ½" NPT, 1 current, 1 freq./pulse and 1 relay output, 24 V AC/DC	E	
MASS 6000, IP67, Polyamide enclosure, cable glands ½" NPT, 1 current, 1 freq./pulse and 1 relay output, 115/230 V AC 50/60 Hz	F	
Cable		
No cable	A	
5 m (16.4 ft) cable	B	
10 m (32.8 ft) cable	C	
25 m (82 ft) cable	D	
50 m (164 ft) cable	E	
75 m (246 ft) cable	F	
150 m (492 ft) cable	G	
Calibration/verification		
Standard calibration 3 flow x 2 points	1	
Stand. calibration matched pair 3 flow x 2 points	2	
Accredited calibration matched pair 5 flow x 2 points (DANAK to ISO 17025)	3	
Extended calibration customer-specified select Y60, Y61, Y62 or Y63 (see additional information)	8	

Dairy MLFB example**MASS 2100**

Sensor size DI 15,
AISI 316L/1.4435

PN 40

DN 15 connector

Standard configuration/calibration

MASS 6000 IP67 compact mounted

No cable

Standard calibration, 3 flow x 2 points

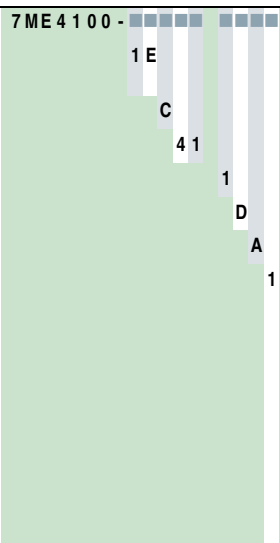
**Selection and Ordering data****Accessories**

Description	Dimension	Order No.
Mating parts for hygienic fittings DIN 11851	DN 10	FDK-085U1016
	DN 15	FDK-085U1017
Includes:	DN 25	FDK-085U1019
• 2 unions	DN 32	FDK-085U1020
• 2 mating parts (for welding in)	DN 40	FDK-085U1021
• 2 EPDM gaskets	DN 50	FDK-085U1022
	DN 65	FDK-085U1023
Mating parts for hygienic clamp ISO 2852	25 mm	FDK-085U1029
	40 mm	FDK-085U1031
Includes:	50 mm	FDK-085U1032
• 2 clamps		
• 2 mating parts		
• 2 EPDM gaskets		
2 EPDM gaskets with collar for mounting set DIN 11851	DN 10	FDK-085U1006
	DN 15	FDK-085U1007
	DN 25	FDK-085U1009
	DN 32	FDK-085U1010
	DN 40	FDK-085U1011
	DN 50	FDK-085U1012
	DN 65	FDK-085U1013

Selection and Ordering data

Order code

Additional information

Please add "-Z" to Order No. and specify Order
code(s) and plain text.

Pressure testing certificate PED: 97/23/EC	C11
Material certificate EN 10204-3.1	C12
Welding certificate NDT X-ray: EN 25817/B DI 3 sensor only: NDT-Penetrant: ISO 3452	C13
Factory certificate according to EN 10204 2.2	C14
Factory certificate according to EN 10204 2.1	C15
Tag name plate, stainless steel	Y17
Tag name plate, plastic	Y18
Customer-specific transmitter setup	Y20
Customer-specified, matched pair (5 x 2)	Y60
Customer-specified calibration (5 x 2)	Y61
Customer-specified, matched pair (10 x 1)	Y62
Customer-specified calibration (10 x 1)	Y63
Cleaned for oil and grease	Y80
Special version	Y99

**Operating instructions for
SITRANS F C MASS 2100 DI 3 to DI 40**

Description	Order No.
• English	A5E02896535
• German	A5E03073519
• Spanish	A5E03073549
• French	A5E03073539

This device is shipped with a Quick Start guide and a CD containing
further SITRANS F literature.

All literature is also available for free at:

<http://www.siemens.com/flowdocumentation>

Description	Length	Order No.
Cable with multiple plug	5 m (16.4 ft)	FDK-083H3015
Standard blue cable between MASS 6000 and MASS 2100, 5 x 2 x 0.34 mm ² twisted and screened in pairs.	10 m (32.8 ft)	FDK-083H3016
Temperature range -20 °C ... +110 °C (-4 °F ... +230 °F)	25 m (82 ft)	FDK-083H3017
	50 m (164 ft)	FDK-083H3018
	75 m (246 ft)	FDK-083H3054
	150 m (492 ft)	FDK-083H3055

Spare parts

Description	Order No.
Adapter for MASS 2100	FDK-083L8889
Multiple plug for cable mounting	FDK-083H5056
2 kB SENSORPROM unit (Sensor Serial No. and Order No. must be specified by ordering)	FDK-083H4410

Flow Measurement

SITRANS F C

Flow sensor MASS 2100 DI 3 to DI 40

Dimensional drawings

MASS 2100 sensor

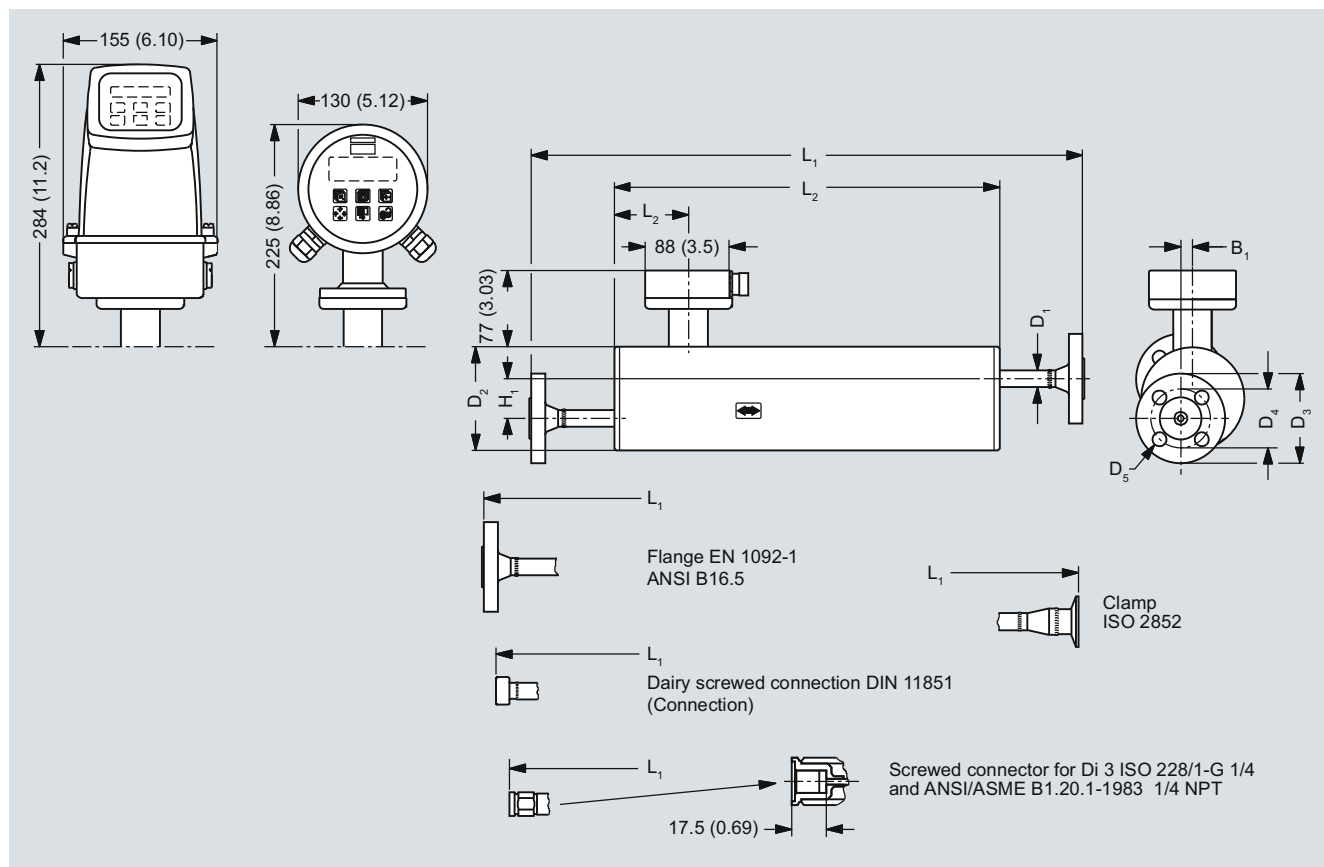

Dimension in mm (inch)

Sensor size	Connections			L1	L2	L3	H1	B1	D1	D2	D3	D4	D5
DI (inch)	Type	Pressure rating	Size	mm	mm	mm	mm	mm	mm	mm	mm	mm	mm
DI 3 (1/8)	Pipe thread ISO 228/1 - G 1/4	PN 100	1/4"	400	280	75.5	60	0	21.3	104	-	-	-
	Pipe thread ANSI/ASME B 1.20.1 - 1/4" NPT	PN 100	1/4"	400	280	75.5	60	0	21.3	104	-	-	-
DI 6 (1/4)	Flange EN 1092-1	PN 100	DN 10	580	390	62.0	40	12	17.0	104	100	70.0	14.0
	Flange EN 1092-1	PN 40	DN 10	560	390	62.0	40	12	17.0	104	90.0	60.0	14.0
	Flange ANSI B16.5	Class 150	1/2"	624	390	62.0	40	12	17.0	104	88.9	60.5	15.7
	Flange ANSI B16.5	Class 600	1/2"	608	390	62.0	40	12	17.0	104	95.3	66.5	15.7
	Screwed connection DIN 11851	PN 40	DN 10	532	390	62.0	40	12	17.0	104	-	-	-
Clamp ISO 2852	PN 16	25 mm	570	390	62.0	40	12	17.0	104	-	-	-	
DI 15 (1/2)	Flange EN 1092-1	PN 100	DN 15	634	444	75.5	44	20	21.3	129	105	75.0	14.0
	Flange EN 1092-1	PN 40	DN 15	620	444	75.5	44	20	21.3	129	95.0	65.0	14.0
	Flange ANSI B16.5	Class 150	1/2"	639	444	75.5	44	20	21.3	129	88.9	60.5	15.7
	Flange ANSI B16.5	Class 600	1/2"	660	444	75.5	44	20	21.3	129	95.3	66.5	15.7
	Screwed connection DIN 11851	PN 40	DN 15	586	444	75.5	44	20	21.3	129	-	-	-
Clamp ISO 2852	PN 16	25 mm	624	444	75.5	44	20	21.3	129	-	-	-	
DI 25 (1)	Flange EN 1092-1	PN 100	DN 25	970	700	75.5	126	25	33.7	219	140.0	100.0	18.0
	Flange EN 1092-1	PN 40	DN 25	934	700	75.5	126	25	33.7	219	115.0	85.0	14.0
	Flange ANSI B16.5	Class 150	1"	967	700	75.5	126	25	33.7	219	108.0	79.2	15.7
	Flange ANSI B16.5	Class 600	1"	992	700	75.5	126	25	33.7	219	124.0	88.9	19.1
	Screwed connection DIN 11851	PN 40	DN 32	922	700	75.5	126	25	33.7	219	-	-	-
Clamp ISO 2852	PN 16	38 mm	940	700	75.5	126	25	33.7	219	-	-	-	
DI 40 (1 1/2)	Flange EN 1092-1	PN 100	DN 40	1100	850	75.5	180	0	48.3	273	170.0	125.0	22.0
	Flange EN 1092-1	PN 40	DN 40	1063	850	75.5	180	0	48.3	273	150.0	110.0	18.0
	Flange ANSI B16.5	Class 150	1 1/2"	1100	850	75.5	180	0	48.3	273	127.0	98.6	15.7
	Flange ANSI B16.5	Class 600	1 1/2"	1128	850	75.5	180	0	48.3	273	155.4	114.3	22.4
	Screwed connection DIN 11851	PN 25	DN 50	1090	850	75.5	180	0	48.3	273	-	-	-
Clamp ISO 2852	PN 25	51 mm	1062	850	75.5	180	0	48.3	273	-	-	-	

Sensor size	Connections			L1	L2	L3	H1	B1	D1	D2	D3	D4	D5
DI (inch)	Type	Pressure rating	Size	inch	inch	inch	inch	inch	inch	inch	inch	inch	inch
DI 3 (1/8)	Pipe thread ISO 228/1 - G¼	PN 100	¼"	15.75	11.02	2.97	2.36	0	0.84	4.09	-	-	-
	Pipe thread ANSI/ASME B 1.20.1 - ¼" NPT	PN 100	¼"	15.75	11.02	2.97	2.36	0	0.84	4.09	-	-	-
DI 6 (¼)	Flange EN 1092-1	PN 100	DN 10	22.83	15.35	2.44	1.57	0.47	0.67	4.09	3.94	2.76	0.55
	Flange EN 1092-1	PN 40	DN 10	22.05	15.35	2.44	1.57	0.47	0.67	4.09	3.54	2.36	0.55
	Flange ANSI B16.5	Class 150	½"	24.57	15.35	2.44	1.57	0.47	0.67	4.09	3.5	2.38	0.62
	Flange ANSI B16.5	Class 600	½"	23.94	15.35	2.44	1.57	0.47	0.67	4.09	3.75	2.62	0.62
	Screwed connection DIN 11851	PN 40	DN 10	20.94	15.35	2.44	1.57	0.47	0.67	4.09	-	-	-
	Clamp ISO 2852	PN 16	25 mm	22.44	15.35	2.44	1.57	0.47	0.67	4.09	-	-	-
DI 15 (½)	Flange EN 1092-1	PN 100	DN 15	24.96	17.48	2.97	1.73	0.79	0.84	5.08	2.95	4.13	0.55
	Flange EN 1092-1	PN 40	DN 15	24.41	17.48	2.97	1.73	0.79	0.84	5.08	3.74	2.56	0.55
	Flange ANSI B16.5	Class 150	½"	25.16	17.48	2.97	1.73	0.79	0.84	5.08	3.5	2.38	0.62
	Flange ANSI B16.5	Class 600	½"	25.98	17.48	2.97	1.73	0.79	0.84	5.08	3.75	2.62	0.62
	Screwed connection DIN 11851	PN 40	DN 15	23.07	17.48	2.97	1.73	0.79	0.84	5.08	-	-	-
	Clamp ISO 2852	PN 16	25 mm	24.57	17.48	2.97	1.73	0.79	0.84	5.08	-	-	-
DI 25 (1)	Flange EN 1092-1	PN 100	DN 25	38.19	27.56	2.97	4.96	0.98	1.33	8.62	3.94	5.51	0.71
	Flange EN 1092-1	PN 40	DN 25	36.77	27.56	2.97	4.96	0.98	1.33	8.62	4.53	3.35	0.55
	Flange ANSI B16.5	Class 150	1"	38.07	27.56	2.97	4.96	0.98	1.33	8.62	4.25	3.12	0.62
	Flange ANSI B16.5	Class 600	1"	39.06	27.56	2.97	4.96	0.98	1.33	8.62	4.88	3.50	0.75
	Screwed connection DIN 11851	PN 40	DN 32	36.30	27.56	2.97	4.96	0.98	1.33	8.62	-	-	-
	Clamp ISO 2852	PN 16	38 mm	37.01	27.56	2.97	4.96	0.98	1.33	8.62	-	-	-
DI 40 (1½)	Flange EN 1092-1	PN 100	DN 40	43.31	33.46	2.97	7.09	0	1.9	10.75	4.92	6.69	0.87
	Flange EN 1092-1	PN 40	DN 40	41.85	33.46	2.97	7.09	0	1.9	10.75	5.91	4.33	0.71
	Flange ANSI B16.5	Class 150	1½"	43.31	33.46	2.97	7.09	0	1.9	10.75	5	3.88	0.62
	Flange ANSI B16.5	Class 600	1½"	44.41	33.46	2.97	7.09	0	1.9	10.75	6.12	4.50	0.88
	Screwed connection DIN 11851	PN 25	DN 50	42.91	33.46	2.97	7.09	0	1.9	10.75	-	-	-
	Clamp ISO 2852	PN 25	51 mm	41.81	33.46	2.97	7.09	0	1.9	10.75	-	-	-

For not listed variants please contact product support.

Flow Measurement

SITRANS F C

Flow sensor MASS 2100 DI 3 to DI 40

MASS 2100 sensor with "heating jacket"

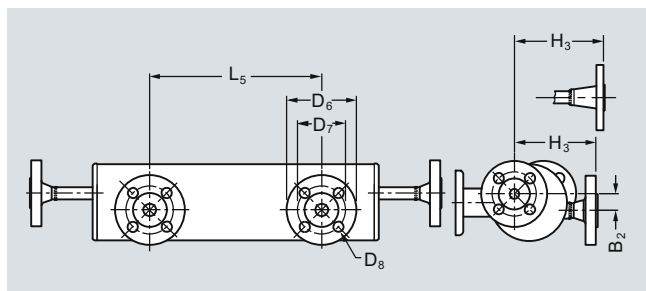

Dimensions in mm (inch)

Sensor size	Connections heated			L5	H3	B2	D6	D7	D8
DI (inch)	Type	Pressure rating	Size	mm (inch)	mm (inch)	mm (inch)	mm (inch)	mm (inch)	mm (inch)
DI 3 (1/8)	EN 1092-1	PN 40	DN 15	234 (9.21)	122 (4.8)	22 (0.87)	95 (3.74)	65.0 (2.56)	14.0 (0.55)
	ANSI B16.5	Class 150	½"	234 (9.21)	131.6 (5.18)	22 (0.87)	88.9 (3.5)	60.5 (2.38)	15.7 (0.62)
DI 6 (¼)	EN 1092-1	PN 40	DN 15	234 (9.21)	112 (4.41)	22.7 (0.89)	95 (3.74)	65.0 (2.56)	14.0 (0.55)
	ANSI B16.5	Class 150	½"	234 (9.21)	121.6 (4.79)	22.7 (0.89)	88.9 (3.5)	60.5 (2.38)	15.7 (0.62)
DI 15 (½)	EN 1092-1	PN 40	DN 15	234 (9.21)	126.5 (4.98)	31.5 (1.24)	95 (3.74)	65.0 (2.56)	14.0 (0.55)
	ANSI B16.5	Class 150	½"	234 (9.21)	136.1 (5.36)	31.5 (1.24)	88.9 (3.5)	60.5 (2.38)	15.7 (0.62)
DI 25 (1)	EN 1092-1	PN 40	DN 15	420 (16.54)	213.6 (8.41)	60 (2.36)	95 (3.74)	65.0 (2.56)	14.0 (0.55)
	ANSI B16.5	Class 150	½"	420 (16.54)	223.2 (8.79)	60 (2.36)	88.9 (3.5)	60.5 (2.38)	15.7 (0.62)
DI 40 (1½)	EN 1092-1	PN 40	DN 15	500 (19.68)	267.5 (10.53)	43 (1.69)	95 (3.74)	65.0 (2.56)	14.0 (0.55)
	ANSI B16.5	Class 150	½"	500 (19.68)	277.1 (10.91)	43 (1.69)	88.9 (3.5)	60.5 (2.38)	15.7 (0.62)

MASS 2100 and MASS 6000 Ex d compact version

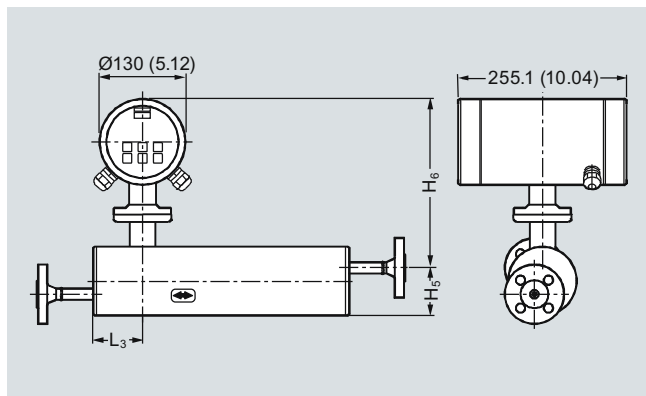

Dimensions in mm (inch)

Sensor size	L ₃	H ₅	H ₆	H ₅ + H ₆
[DI (inch)]	[mm (inch)]	[mm (inch)]	[mm (inch)]	[mm (inch)]
3 (1/8)	75 (2.95)	82 (3.23)	247 (9.72)	329 (12.95)
6 (¼)	62 (2.44)	72 (2.83)	257 (10.12)	329 (12.95)
15 (½)	75 (2.95)	87 (3.43)	267 (10.51)	354 (13.94)
25 (1)	75 (2.95)	173 (6.81)	271 (10.67)	444 (17.48)
40 (1½)	75 (2.95)	227 (8.94)	271 (10.67)	498 (19.61)

MASS 2100 and MASS 6000 IP67 compact version

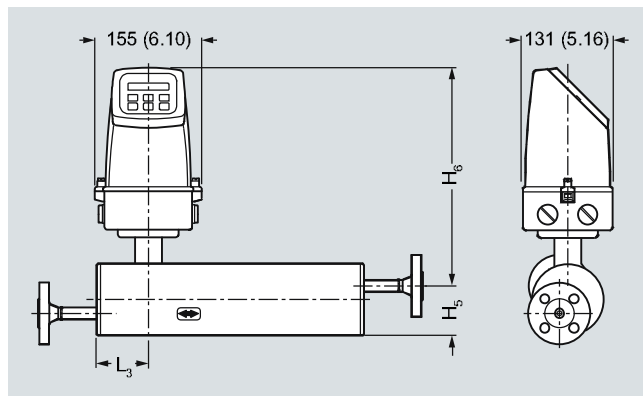

Dimensions in mm (inch)

Sensor size	L ₃	H ₅	H ₆	H ₅ + H ₆
[DI (inch)]	[mm (inch)]	[mm (inch)]	[mm (inch)]	[mm (inch)]
3 (1/8)	75 (2.95)	82 (3.23)	306 (12.04)	388 (15.28)
6 (¼)	62 (2.44)	72 (2.83)	316 (12.44)	388 (15.28)
15 (½)	75 (2.95)	87 (3.43)	326 (12.83)	413 (16.26)
25 (1)	75 (2.95)	173 (6.81)	330 (13.00)	503 (19.80)
40 (1½)	75 (2.95)	227 (8.94)	330 (13.00)	557 (21.93)

Overview



SITRANS F C MC2 is available as a:

- Standard version (DN 50 to DN 150 (2" to 6"))
- Hygienic EHEDG-certified version (DN 20 to DN 80 (¾" to 3"))

The MC2 sensor is suitable for accurate mass flow measurement of a variety of liquids and gases.

The sensor offers superior performance in terms of flow accuracy, turn-down ratio and density accuracy and delivers true multi-parameter measurements i.e.: mass flow, volume flow, density, temperature and fraction flow.

The very compact sensor construction makes installation and commissioning of even the largest sizes very straight forward and easy.

Benefits

- High accuracy better than 0.15 % of mass flow rate
- Large dynamic turn-down ratio
- Densitometer performance available through density accuracy better than 0.001 g/cm³
- Space-saving split-flow sensor design facilitating low pressure loss
- Parallel S-tube design and optimal oriented inductive sensors enhances accuracy and turn-down ratio.
- Self-draining in both horizontal and vertical position
- Rigid enclosure design reduces the influence from pipeline vibration and thermal stress
- 4-wire Pt100 temperature measurement ensures optimum accuracy on mass flow, density and fraction flow
- SENSORPROM enables true "plug & play" - installed and commissioned in less than 10 minutes.
- Safe Ex design EEx em [ib] IIC
- Sensor pipe available in high-quality stainless steel AISI 316L/1.4571 or Hastelloy C4/2.4610 offering optimum corrosion resistance.
- The sensor calibration is also valid for gas measurement.
- CIP cleanability for food and beverage and pharmaceutical applications

Application

Coriolis mass flowmeters are suitable for measuring all liquids and gases. The measurement is independent of changes in process conditions/parameters such as temperature, density, pressure, viscosity, conductivity, and flow profile.

Due to this versatility the meter is easy to install and the Coriolis flowmeter is recognized for its high accuracy in a wide turndown ratio which is paramount in many applications.

The main applications of the Coriolis flowmeter can be found in all industries, such as:

Chemical and pharma	Detergents, bulk chemicals, pharmaceuticals, acids, alkalis
Food and beverage	Dairy products, beer, wine, soft-drinks, plato/brix, fruit juices and pulps, bottling, CO ₂ dosing, CIP-liquids
Oil and gas	Gas measurement, furnace control, test separators, LPG, oil bunkering
Water and waste water	Dosing of chemicals for water treatment

The wide variety of combinations and versions from the modular system means that ideal adaptation is possible to each measuring task.

The MC2 sensor is also available in a hygienic version which is EHEDG-approved. This is of particular interest for the food and beverage and pharmaceutical markets where the EHEDG approval is often requested for optimum hygienic and process safety.

Design

The MC2 sensor consists of 2 parallel measuring pipes, welded directly onto a flow-splitter at each end to eliminate a direct coupling to the process connectors and significantly reduce effects from external vibrations.

The flow-splitters are welded onto a rigid sensor housing which acts as a mechanical low-pass filter.

The sensor is available in 2 material configurations, AISI 316L/1.4436 or Hastelloy C4/2.4610 with a wide variety of process connections.

The enclosure is made of stainless steel AISI 304/1.4301 with an encapsulation grade of IP67/NEMA 4.

The sensor is Ex-approved EEx em [ib] IIC.

It can be installed in horizontal or vertical position, and is self-draining in both positions.

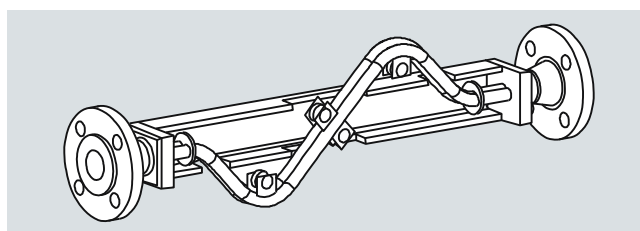

The MC2 sensor is based on a different Ex concept than MASS 6000. Therefore the MC2 sensor can only be connected to MASS 6000 IP67, MASS 6000 19" or SIFLOW FC070 standard versions, which have to be remote mounted in the safe area. MASS 6000 Ex d and SIFLOW FC070 Ex CT can **not** be used with MC2 sensors.



Hazardous area
Zone 1 + 2



Safe area

Flow Measurement SITRANS F C

Flow sensor MC2

Function

The measuring principle is based on the Coriolis effect. See "System information Coriolis mass flowmeters".

Integration

Installation guidelines MC2 DN 50 ... DN 150

Installation of sensor

The optimal installation orientation is a vertical installation with an upward flow as shown in the following figure. This has the advantage that any solids contained in the fluid will settle downward and gas bubbles will move upward out of the meter tube when the flow rate is zero. Additionally, it is easy to drain the meter tube. Deposits can thereby be avoided.

Vertical orientation:

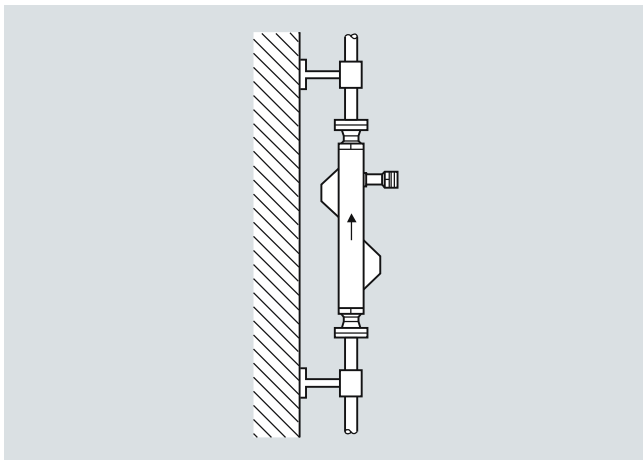

Vertical installation self-draining (upward flow)

Horizontal orientation, self-draining

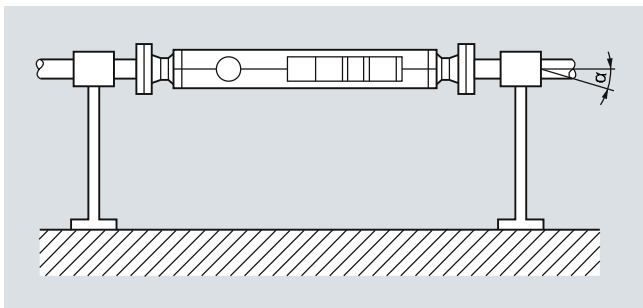

Avoid vibrations

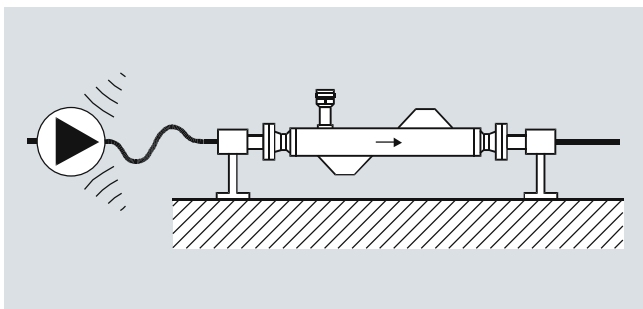

Avoid cross talk

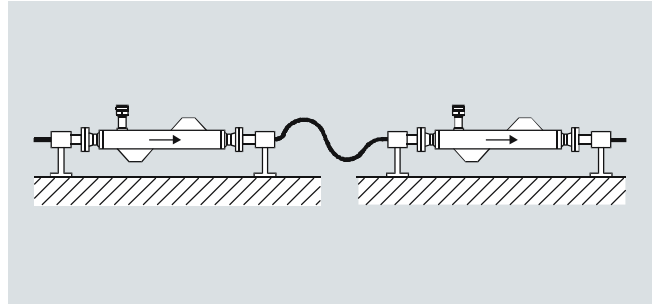

Installation in a drop line

Mount with reduction (A) or orifice (B) to prevent partially draining.

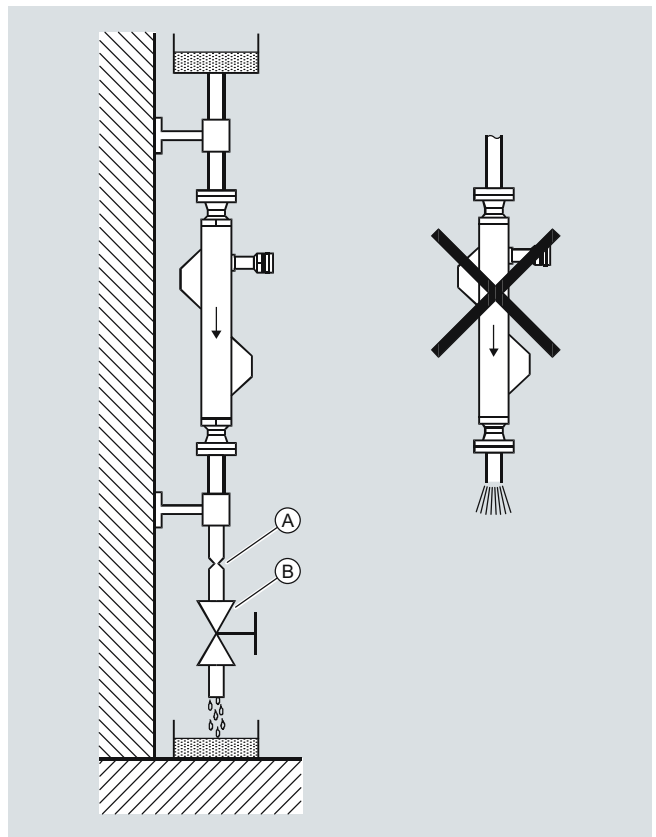

Installation in a drop line

Technical specifications

Versions (mm (inch))		20 (¾)	25 (1)	40 (1½)	50 (2)	65 (2½)	80 (3)	100 (4)	150 (6)
Inside pipe diameter	mm (inch)	8.0 (0.31)	10.0 (0.39)	16.0 (0.63)	22.0 (0.87)	29.0 (1.14)	34.0 (1.34)	43.1 (1.69)	76.1 (2.99)
Pipe wall thickness	mm (inch)	1.0 (0.04)	1.0 (0.04)	1.0 (0.04)	1.5 (0.06)	1.5 (0.06)	2.0 (0.08)	2.6 (0.10)	3.2 (0.13)
Mass flow measuring range at pressure drop of 2 bar (29 psi) at 1 g/cm³ (0.036 lb/inch³)	kg/h (lb/h)	4 600 (10 141)	7 360 (16 226)	21 850 (48 171)	55 200 (121 695)	113 400 (250 000)	147 600 (325 401)	249 600 (550 273)	660 000 (1 455 049)
Density	g/cm³ (lb/inch³)	0.5 ... 3.5 (0.18 ... 0.126)							
Fraction e.g. Brix	°Brix	0 ... 100							
Temperature									
Standard-version					-50 ... +200 °C (-58 ... +392 °F)				
Ex-version					-50 ... +200 °C (-58 ... +392 °F)				
Liquid pressure measuring pipe		20	25	40					
Stainless steel (DIN 2413, 20 °C (68 °F))	bar (psi)	100 (1450)	100 (1450)	100 (1450)	100 (1450)	100 (1450)	100 (1450)	40 (580)	40 (580)
Materials									
Measuring pipe				Stainless steel AISI 316Ti/1.4571 or Hastelloy C4/2.4610					
Flange				Stainless steel AISI 316Ti/1.4571 or Hastelloy C4/2.4610					
Enclosure									
Enclosure material/ connection box				IP67 AISI 304 (1.4301)/aluminum, max. pressure 40 bar (580 psi)					
Process connections									
Electrical connections					See dimensional drawings Screw terminals, M 20				
Cable					5 x 2 x 0.35 mm ² twisted and screened in pairs, ext. Ø 12 mm				
Cable length					10, 25, 75 or 150 m (32.8, 82, 246 or 492 ft.)				
Ex-version									
ATEX 1443X					≤ DN 40: II 1/2 EEx em [ib] IIC T2-T6 ≥ DN 50: II 2G EEx em [ib] IIC T2-T6				
Weight approx.	kg (lb)	13 (28)	14 (31)	18 (40)	34 (75)	47 (104)	58 (128)	91 (201)	261 (573)

For accuracy specifications see „System information Coriolis mass flowmeters“.

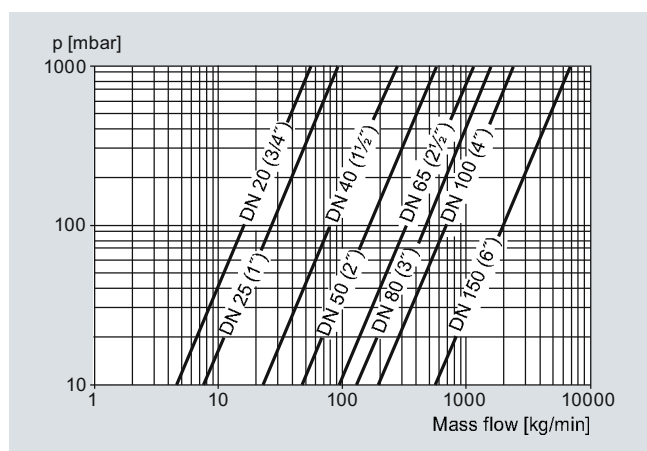
Pressure drop

Flow Measurement

SITRANS F C

Flow sensor MC2

Selection and Ordering data	Order No.	Order code
SITRANS F C flow sensors MC2	7ME4300-	
Nominal diameter		
Stainless steel AISI 316Ti/1.4571		
DN 50	1 A	
DN 65	1 B	
DN 80	1 C	
DN 100	1 D	
DN 150	1 E	
Hastelloy C4/2.4610		
DN 50	2 A	
DN 65	2 B	
DN 80	2 C	
DN 100	2 D	
DN 150	2 E	
Nominal pressure		
PN 40	A	
PN 100	B	
Class 150	C	
Class 300	D	
Class 600	E	
Clamps/screwed-connections	F	
Process connections		
Flange EN 1092-1		
DN 50 (PN 40/PN 100)	2 0	
DN 65 (PN 40/PN 100)	2 1	
DN 80 (PN 40/PN 100)	2 2	
DN 100 (PN 40)	2 3	
DN 150 (PN 40)	2 4	
Flange ASME/ANSI		
2" (class 150/300/600)	3 0	
2 1/2" (class 150/300/600)	3 1	
3" (class 150/300/600)	3 2	
4" (class 150/300)	3 3	
6" (class 150/300)	3 4	
Dairy screwed connection to DIN 11851		
DN 50 (PN 25)	4 0	
DN 65 (PN 25)	4 1	
DN 80 (PN 25)	4 2	
DN 100 (PN 25)	4 3	
Dairy clamp connection DIN 32676 Tri-clamp		
50 mm clamp (PN 16)	5 0	
66 mm clamp (PN 10)	5 1	
81 mm clamp (PN 10)	5 2	
100 mm clamp (PN 10)	5 3	
Aseptic nut flange DIN 11864-2 form A for pipes dimensioned by DIN 11866		
DN 40 (1 1/2")	6 0	
DN 50 (2")	6 1	
DN 65 (2 1/2")	6 2	
DN 80 (3")	6 3	
DN 100 (4")	6 4	
Configuration		
Flow and density (5 kg/m ³ [0.31 lb/ft ³])	1	
Flow, Brix/Plato and density (1 kg/m ³ [0.06 lb/ft ³]) ¹⁾	2	
Density (1 kg/m ³ [0.06 lb/ft ³]) ¹⁾	5	
Fraction (specified by customer) and density (1 kg/m ³ [0.06 lb/ft ³]) ¹⁾	9	NO Y

Selection and Ordering data	Order No.	Order code
SITRANS F C flow sensors MC2	7ME4300-	
Ex-approval		
Standard, without explosion protection		A
With explosion protection: Ex, ATEX		B
Cable		
No cable (see accessories)		A
Calibration		
Standard		1
Matched pair		2
Extended calibration customer-specified select Y60, Y61, Y62 or Y63 (see additional information)		8

¹⁾ Extended density and fraction not possible with DN 150.

Please also see www.siemens.com/SITRANSForordering for practical examples of ordering

Dairy MLFB example	Order No.
MC2 sensor	7ME4300-
Sensor size DN 80. AISI 316Ti/1.4571	1 C
Nominal pressure: Clamps	F
DIN 11851, DN 80, PN 25	4 2
	
Configuration/calibration type: flow and density (5 kg/m ³ [0.31 lb/ft ³])	1
Without Ex approval	A
No cable	A
Standard calibration	1

Selection and Ordering data	Order code
Additional information	
Please add "-Z" to Order No. and specify Order code(s) and plain text.	
Pressure testing certificate PED: 97/23/EC	C11
Material certificate EN 10204-3.1	C12
Welding certificate NDT X-ray: EN 25817/B	C13
Factory certificate according to EN 10204 2.2	C14
Factory certificate according to EN 10204 2.1	C15
Material certificate according to NACE	C16
Tag name plate, stainless steel	Y17
Customer-specified, matched pair (5 x 2)	Y60
Customer-specified calibration (5 x 2)	Y61
Customer-specified, matched pair (10 x 1)	Y62
Customer-specified calibration (10 x 1)	Y63
Special version	Y99

Operating instructions for SITRANS F C MC2

Description	Order No.
• English	A5E02154544
• German	A5E02407329
• Spanish	A5E02384868
• French	A5E02384945

This device is shipped with a Quick Start guide and a CD containing further SITRANS F literature.

All literature is also available for free at:
<http://www.siemens.com/flowdocumentation>

Flow Measurement

SITRANS F C

Flow sensor MC2

Accessories

Description	Order No.
Cables from MC2 sensor to MASS 6000 transmitter	
10 m (32.8 ft)	FDK-083H3001
25 m (82 ft)	FDK-083H3002
75 m (246 ft)	FDK-083H3003
150 m (492 ft)	FDK-083H3004
Spare parts	
Description	Order No.
2 kB SENSORPROM unit (Sensor Serial No. and Order No. must be specified at ordering)	FDK-083H4410
Connection board/PCB	A5E03004110

Selection and Ordering data

Description	Order No.	Order code
SITRANS F C flow sensors		
MC2 for Hygienic applications only	7 ME 4 3 1 0 -	
Cable		
No cable (see accessories)		
Calibration		
Standard		1
Matched pair		2

¹⁾ Extended density and fraction not possible with DN 150.

Please also see www.siemens.com/SITRANSOrdering for practical examples of ordering

Selection and Ordering data

Description	Order No.	Order code
SITRANS F C flow sensors		
MC2 for Hygienic applications only	7 ME 4 3 1 0 -	
Nominal diameter		
ANSI 316L/1.4435		
DN 20	1 A	
DN 25	1 B	
DN 40	1 C	
DN 50	1 D	
DN 65	1 E	
DN 80	1 F	
Nominal pressure 40 bar, PN 25		
Clamps/screwed-connections	F	
Pressure and Process connections		
<u>Dairy screwed connection to DIN 11851</u>		
DN 20, PN 25	4 0	
DN 25, PN 25	4 1	
DN 40, PN 25	4 2	
DN 50, PN 25	4 3	
DN 65, PN 25	4 4	
DN 80, PN 25	4 5	
<u>Dairy clamp connectors for DIN 32676</u>		
<u>Tri-clamp</u>		
20 mm clamp	4 7	
26 mm clamp	4 8	
38 mm clamp	5 4	
50 mm clamp	5 0	
66 mm clamp	5 1	
81 mm clamp	5 2	
<u>Aseptic connectors DIN 11864-2 Form A for DIN tubes</u>		
DN 20	5 8	
DN 25	5 7	
DN 40	6 0	
DN 50	6 1	
DN 65	6 2	
DN 80	6 3	
Configuration		
Flow and density (5 kg/m ³)	1	
Flow, BRIX/PLATO and density (1 kg/m ³) ¹⁾	2	
Density (1 kg/m ³) ¹⁾	5	
Flow, fraction (customer-specified application from the net)	9	N O Y
Ex-approval		
Standard, without explosion protection	A	
With explosion protection: Ex, FM Class I, Div 2	D	

Selection and Ordering data

Description	Order code
Additional information	
Please add "-Z" to Order No. and specify Order code(s) and plain text.	
Pressure testing certificate PED: 97/23/EC	C11
Material certificate EN 10204-3.1	C12
Welding certificate NDT X-ray: EN 25817/B	C13
Factory certificate according to EN 10204 2.2	C14
Factory certificate according to EN 10204 2.1	C15
Tag name plate, stainless steel	Y17
Tag name plate, plastic	Y18
Customer-specific transmitter setup	Y20
Customer-specified, matched pair (5 x 2)	Y60
Customer-specified calibration (5 x 2)	Y61
Customer-specified, matched pair (10 x 1)	Y62
Customer-specified calibration (10 x 1)	Y63
Special version	Y99

Accessories

Description	Order No.
Cables from MC2 sensor to MASS 6000 transmitter	
10 m (32.8 ft)	FDK-083H3001
25 m (82 ft)	FDK-083H3002
75 m (246 ft)	FDK-083H3003
150 m (492 ft)	FDK-083H3004

Spare parts

Description	Order No.
2 kB SENSORPROM unit (Sensor Serial No. and Order No. must be specified by ordering)	FDK-083H4410

Flow Measurement SITRANS F C

Flow sensor MC2

Dairy MLFB example	Order No.
<p>MC2 sensor</p> <p>Sensor size DN 40 AISI 316L/1.4435 Nominal pressure: Clamp DIN 11851, DN 40, PN 25</p>  <p>Configuration/calibration type: flow and density (5 kg/m³ [0.31 lb/ft³]) Without Ex approval No cable Standard calibration</p>	<p>7ME4310 - - - - -</p> <p>1 C F 4 2</p> <p>1 A A 1</p>

4

Dimensional drawings

Remote design, flanged construction, DIN/ANSI

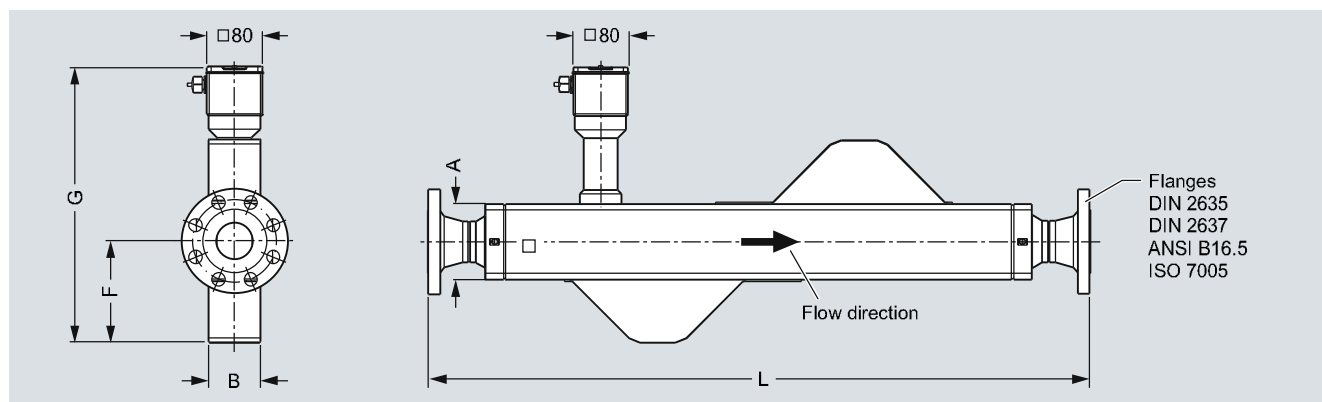

Meter size	Process connection size		L [mm (inch)]						G ¹⁾ [mm (inch)]	F [mm (inch)]	B [mm (inch)]	A [mm (inch)]	Weight [kg (lb)]	
			DIN 11864-2 form A	DIN 2635 PN 40	DIN 2637 PN 100	ANSI CL 150	ANSI CL 300	ANSI CL 600						
2	50	2	50	918 (36.14)	940 (37.01)	979 (38.54)	970 (38.19)	980 (38.58)	1001 (39.41)	403 (15.87)	148 (5.83)	80 (3.15)	110 (4.33)	34 (75)
		2½	65	1081 (42.56)	1100 (43.31)	1148 (45.20)	1218 (47.95)	1228 (48.35)	1248 (49.13)	429 (16.89)	164 (6.44)	97 (3.82)	130 (5.12)	38 (84)
2½	65	2	50	1197 (47.13)	1220 (48.03)	1259 (49.57)	1250 (49.21)	1260 (49.61)	1281 (50.43)	429 (16.89)	164 (6.64)	97 (3.82)	130 (5.12)	43 (95)
		2½	65	1081 (42.56)	1100 (43.31)	1148 (45.20)	1218 (47.95)	1228 (48.35)	1249 (49.17)	429 (16.89)	164 (6.64)	97 (3.82)	130 (5.12)	47 (104)
		3	80	1200 (47.24)	1220 (48.03)	1260 (49.61)	1240 (48.82)	1260 (49.61)	1282 (50.47)	429 (16.89)	164 (6.64)	97 (3.82)	130 (5.12)	50 (110)
3	80	2½	65	1310 (51.57)	1330 (52.36)	1378 (54.25)	1365 (53.74)	1375 (54.13)	1396 (54.96)	456 (17.95)	186 (7.32)	108 (4.25)	140 (5.51)	56 (123)
		3	80	1200 (47.24)	1220 (48.03)	1260 (49.61)	1240 (48.82)	1260 (49.61)	1282 (50.47)	456 (17.95)	186 (7.32)	108 (4.25)	140 (5.51)	58 (128)
		4	100	1463 (57.60)	1480 (58.27)	1530 (60.24)	1500 (59.06)	1520 (59.84)	1568 (61.73)	456 (17.95)	186 (7.32)	108 (4.25)	140 (5.51)	69 (152)
		3	80	1618 (63.70)	1640 (64.57)	1680 (66.14)	1660 (65.35)	1680 (66.14)	1702 (67.01)	500 (19.69)	215 (8.46)	131 (5.16)	170 (6.69)	84 (185)
4	100	4	100	1463 (57.60)	1480 (58.27)	1530 (60.24)	1500 (59.06)	1520 (59.84)	1568 (61.73)	500 (19.69)	215 (8.46)	131 (5.16)	170 (6.69)	91 (201)
		6	150	N/A	1778 (69.92)	N/A	1806 (71.10)	1826 (71.89)	N/A	500 (19.69)	215 (8.46)	131 (5.16)	170 (6.69)	120 (265)
		6	150	N/A	2040 (80.31)	N/A	2070 (81.50)	2090 (82.28)	N/A	613 (24.13)	285 (11.22)	190 (7.84)	260 (9.84)	260 (573)

1) For EEx add 54 mm

Remote design, food industry fittings, DIN 11851

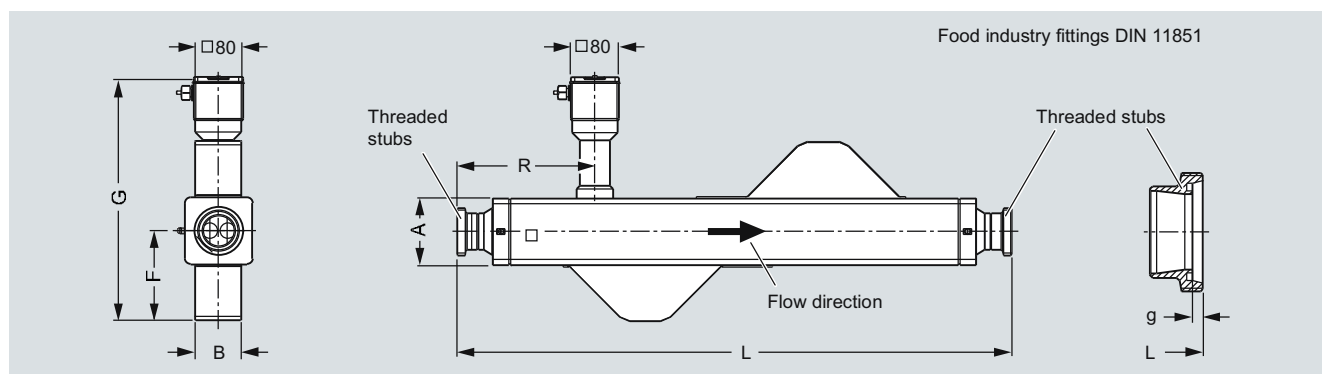

Meter size	Process connection size			L [mm (inch)]	g [mm (inch)]	G ¹⁾ [mm (inch)]	F [mm (inch)]	B [mm (inch)]	A [mm (inch)]	R [mm (inch)]	Weight [kg (lb)]	
												inch
2	50	2	50	Rd 78 x 1/6	918 (36.14)	7 (0.28)	403 (15.87)	148 (5.83)	80 (3.15)	110 (4.33)	177 (6.97)	30 (66)
		2½	65	Rd 95 x 1/6	1081 (42.56)	8 (0.31)	403 (15.87)	148 (5.83)	80 (3.15)	110 (4.33)	254 (10.00)	34 (75)
2½	65	2	50	Rd 78 x 1/6	1197 (47.13)	7 (0.28)	429 (16.89)	164 (6.46)	97 (3.82)	130 (5.12)	291 (11.46)	40 (88)
		2½	65	Rd 95 x 1/6	1081 (42.56)	8 (0.31)	429 (16.89)	164 (6.46)	97 (3.82)	130 (5.12)	227 (10.91)	44 (97)
		3	80	Rd 110 x 1/6	1200 (47.24)	8 (0.31)	429 (16.89)	164 (6.46)	97 (3.82)	130 (5.12)	281 (11.06)	47 (104)
3	80	2½	65	Rd 95 x 1/6	1310 (51.57)	8 (0.31)	456 (17.95)	186 (7.32)	108 (4.25)	140 (5.51)	319 (12.56)	54 (119)
		3	80	Rd 110 x 1/6	1200 (47.24)	8 (0.31)	456 (17.95)	186 (7.32)	108 (4.25)	140 (5.51)	258 (10.16)	56 (123)
		4	100	Rd 110 x 1/6	1463 (57.60)	10 (0.39)	456 (17.95)	186 (7.32)	108 (4.25)	140 (5.51)	381 (15.00)	60 (132)
4	100	3	80	Rd 110 x 1/6	1618 (63.70)	8 (0.31)	500 (19.69)	215 (8.46)	131 (5.16)	170 (6.69)	401 (15.79)	82 (180)
		4	100	Rd 130 x ¼	1463 (57.60)	10 (0.39)	500 (19.69)	215 (8.46)	131 (5.16)	170 (6.69)	314 (12.36)	86 (190)

1) For EEx add 54 mm

Flow Measurement

SITRANS F C

Flow sensor MC2

Remote design, Tri-clamp DIN 32676 (ISO 2852)

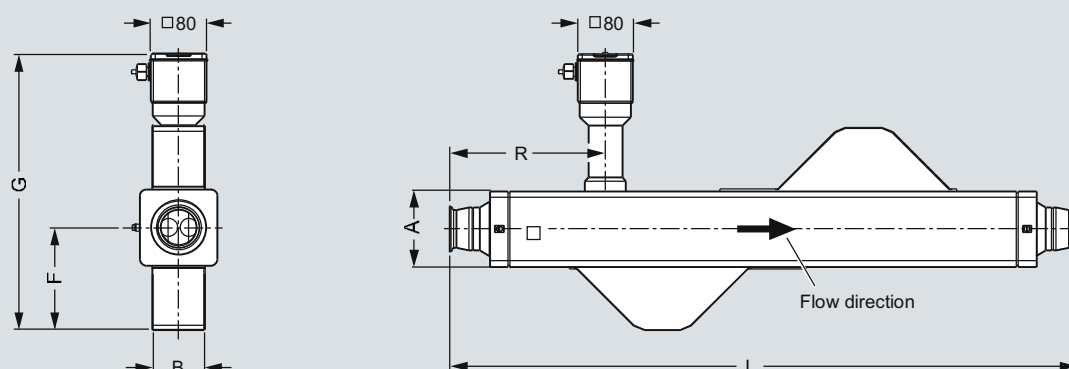

Dimensions in mm (inch)

Meter size		Process connection size		L [mm (inch)] ± 3	G ¹⁾ [mm (inch)]	F [mm (inch)]	B [mm (inch)]	A [mm (inch)]	R [mm (inch)]	Weight [kg (lb)]		
inch	DN	inch	DN									
2	50	2	50	913 (35.94)	403 (15.87)	148 (5.83)	80 (3.15)	110 (4.33)	225 (8.86)	26 (57)		
		2½	65	1073 (42.24)							305 (12.01)	27 (60)
2½	65	2	50	1192 (46.93)	429 (16.89)	164 (6.64)	97 (3.82)	130 (5.12)	335 (13.19)	36 (79)		
		2½	65	1073 (42.24)							275 (10.83)	37 (82)
		3	80	1180 (46.46)							328 (12.91)	38 (84)
3	80	2½	65	1302 (51.26)	456 (17.95)	186 (7.32)	108 (4.25)	140 (5.51)	378 (14.88)	45 (99)		
		3	80	1180 (46.46)							296 (11.65)	44 (97)
		4	100	1448 (57.01)							430 (16.93)	46 (101)
4	100	3	80	1598 (62.91)	500 (19.69)	215 (8.46)	131 (5.16)	170 (6.69)	440 (17.32)	71 (157)		
		4	100	1448 (57.01)							365 (14.37)	69 (152)

¹⁾ For EEx add 54 mm

Process Connections

- Flanges DIN/ASME
- Tri-Clamp DIN 32676
 - DN 15 to DN 50: Series 3
 - DN 65 to DN 100: Series 1
- Food Industry fittings DIN 11851

The max. allowable operating pressure is a function of the process connection type, the fluid temperature, the bolts and the gaskets.

Pressure Rating

- PN 16, PN 40, PN 100 (to DN 80 (3"))
 - Class 150, Class 300, Class 600 (to DN 80 (3"))

Housing as secondary containment

- Max. 40 bar

Pressure Equipment Directive 97/23/EG

- Conformity evaluation category III, fluid group 1, gas, diagramme 6

Corrosion resistance of measuring pipe material to measuring medium has to be considered.

Material strength for process connections

Process connection	Size		PS _{max.} at 20 °C (68 °F)	TS _{max.}	TS _{min.}
	DN	inch			
Thread acc. DIN 11851	15 ... 40	½ ... 1½	40 (580)	140 (284)	-40 (-40)
	50 ... 100	2 ... 4	25 (363)	140 (284)	-40 (-40)
Tri-Clamp acc. DIN 32676	15 ... 50	½ ... 2	16 (232)	120 (248)	-40 (-40)
	65 ... 100	2½ ... 4	10 (145)	120 (248)	-40 (-40)

Pressure/temperature curves

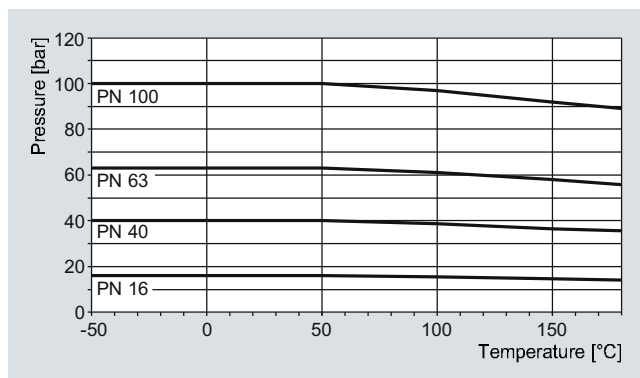

DIN-Flanges stainless steel AISI 316Ti/1.4571 to DN 100 (4")

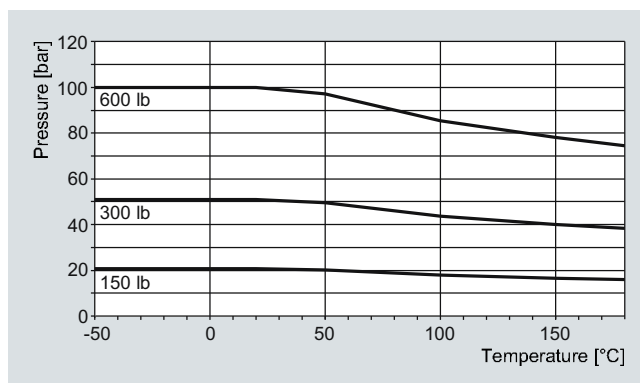

ASME-Flanges stainless steel AISI 326Ti/1.4571 to DN 100 (4")

For further information on the PED standard and requirements, see page 10/9.

Flow Measurement

SITRANS F C

Flow sensor MC2

Remote Design, Food Industry Fitting, DIN 11851

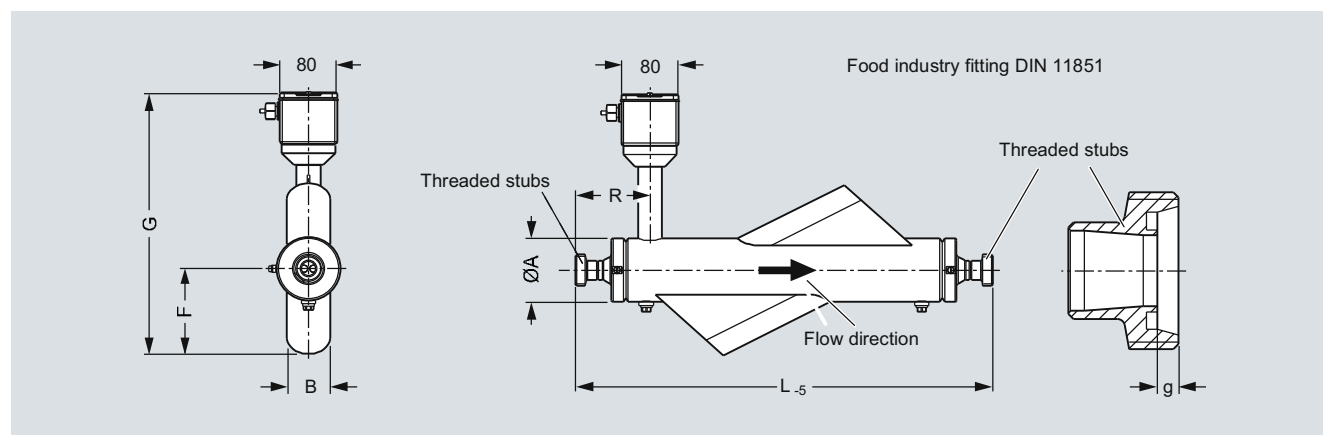

DN (Size)		Process connections			L ₅	g	G	F	B	∅A	R	Weight
DN	inch	DN	inch		mm (inch)	mm (inch)	mm (inch)	mm (inch)	mm (inch)	mm (inch)	mm (inch)	kg (lb)
20	¾	15	½	Rd34 x 1/8	672 (26.46)	4 (0.16)	358 (14.94)	127 (5.00)	66 (2.60)	89 (3.50)	152 (5.98)	13 (29)
		20	¾	Rd44 x 1/6	583 (22.95)	6 (0.24)					102 (4.02)	
		25	1	Rd52 x 1/6	683 (26.89)	7 (0.28)					152 (5.98)	
25	1	20	¾	Rd44 x 1/6	743 (29.25)	6 (0.24)	358 (14.94)	127 (5.00)	66 (2.60)	89 (3.50)	162 (6.38)	14 (31)
		25	1	Rd52 x 1/6	643 (25.31)	7 (0.28)					112 (4.11)	
		40	1½	Rd65 x 1/6	786 (30.94)	7 (0.28)					185 (7.28)	



If this connection is supplied with an EHEDG-certified device, the device nominal sizes must correspond with the connection nominal sizes!

Remote Design, Food Industry Fitting, DIN 11851

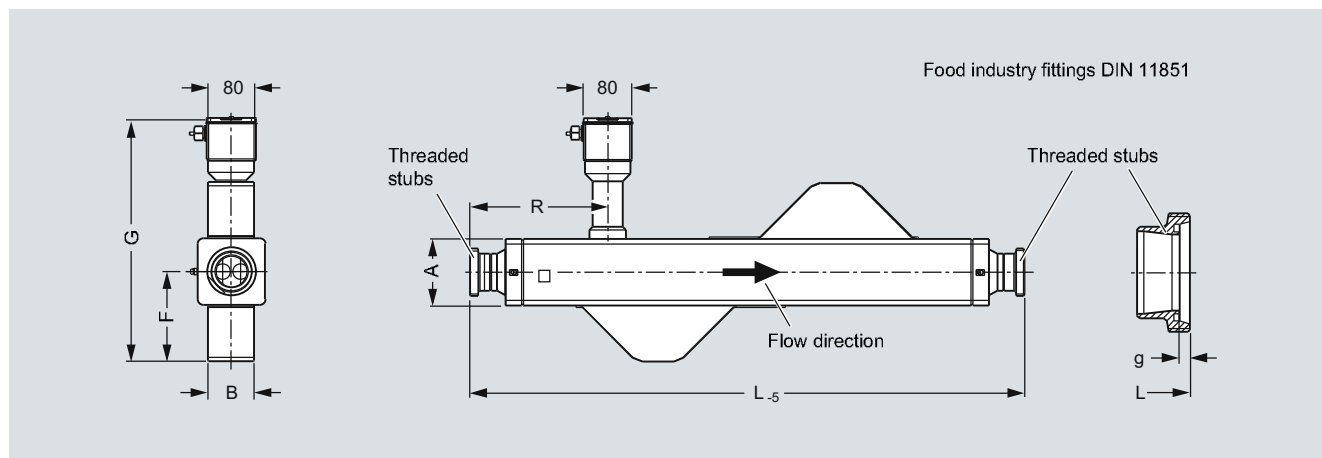

DN (Size)	Process connections		L ₅	g	G	F	B	∅A	R	Weight			
DN	inch	DN	inch	mm (inch)	mm (inch)	mm (inch)	mm (inch)	mm (inch)	mm (inch)	kg (lb)			
40	1½	25	1	Rd52 x 1/6	864 (34.02)	7 (0.28)	374 (14.72)	129 (5.08)	64 (2.52)	90 (3.54)	218 (8.58)	16 (35)	
		40	1½	Rd65 x 1/6	761 (29.96)	7 (0.28)					164 (6.46)	18 (40)	
		50	2	Rd78 x 1/6	918 (36.14)	7 (0.28)						241 (9.49)	19 (42)
50	2	40	1½	Rd65 x 1/6	1025 (40.35)	7 (0.28)	403 (15.87)	148 (5.83)	80 (3.15)	110 (4.33)	233 (9.17)	28 (62)	
		50	2	Rd78 x 1/6	918 (36.14)	7 (0.28)						177 (6.97)	30 (66)
		65	2½	Rd95 x 1/6	1081 (42.56)	8 (0.31)						254 (10.00)	34 (75)
65	2½	50	2	Rd78 x 1/6	1197 (47.13)	7 (0.28)	429 (16.89)	164 (6.46)	97 (3.82)	130 (5.12)	291 (11.46)	40 (88)	
		65	2½	Rd95 x 1/6	1081 (42.56)	8 (0.31)						227 (8.94)	44 (97)
		80	3	Rd110 x 1/4	1200 (47.24)	8 (0.31)						281 (11.06)	47 (104)
80	3	65	2½	Rd95 x 1/6	1310 (51.57)	8 (0.31)	456 (17.95)	186 (7.32)	108 (4.25)	140 (5.51)	319 (12.56)	54 (119)	
		80	3	Rd110 x 1/4	1200 (47.24)	8 (0.31)						258 (10.16)	56 (123)
		100	4	Rd130 x 1/4	1463 (57.60)	10 (0.39)						381 (15.00)	60 (132)



If this connection is supplied with an EHEDG-certified device, the device nominal sizes must correspond with the connection nominal sizes!

Flow Measurement

SITRANS F C

Flow sensor MC2

Remote Design, Tri-Clamp DIN 32676

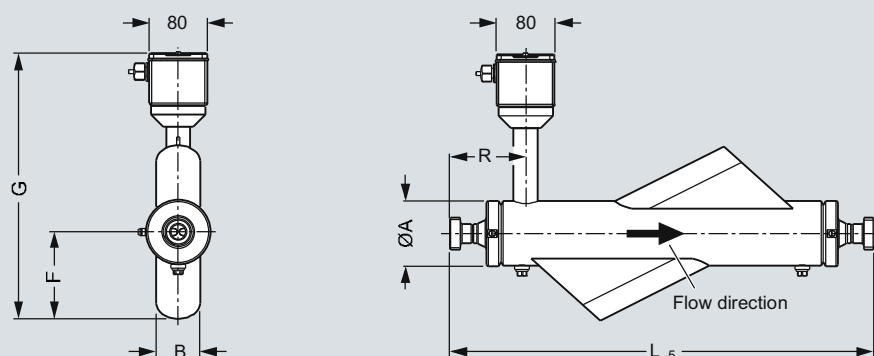

DN (Size)		Process connections			L ₅ mm (inch)	G mm (inch)	F mm (inch)	B mm (inch)	ØA mm (inch)	R mm (inch)	Weight kg (lb)
DN	inch	DN	inch								
20	¾	15	½	DIN 32676	656 (25.83)	358 (14.09)	127 (5.00)	66 (2.60)	89 (3.50)	140 (5.51)	12 (26)
		20	¾		561 (22.09)					92 (3.62)	
		25	1		661 (26.02)					142 (5.59)	
25	1	20	¾	DIN 32676	721 (28.39)	358 (14.09)	127 (5.00)	66 (2.60)	89 (3.50)	152 (5.98)	13 (29)
		25	1		621 (24.45)					102 (4.02)	
		40	1½		773 (30.43)					180 (7.09)	



If this connection is supplied with an EHEDG-certified device, the device nominal sizes must correspond with the connection nominal sizes!

Remote Design, Tri-Clamp DIN 32676

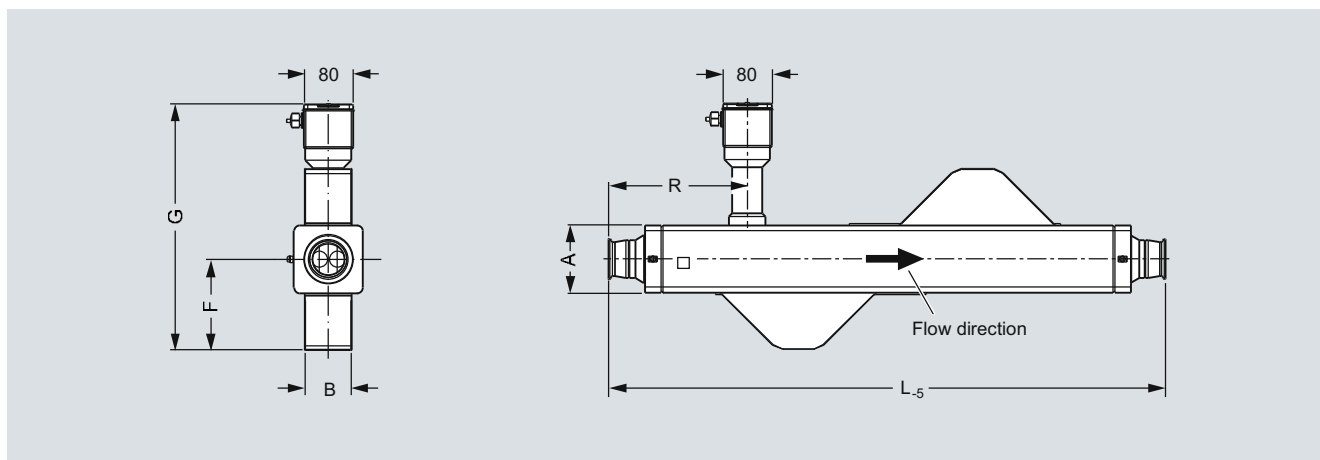

DN (Size)		Process connections		L ₅	G	F	B	∅A	R	Weight
DN	inch	DN	inch	mm (inch)	mm (inch)	mm (inch)	mm (inch)	mm (inch)	mm (inch)	kg (lb)
40	1½	25	1	842 (33.15)	374 (14.72)	129 (5.08)	64 (2.52)	90 (3.54)	242 (9.53)	17 (37)
		40	1½	748 (29.45)					195 (7.68)	17 (37)
		50	2	913 (35.94)					278 (10.94)	18 (40)
50	2	40	1½	1012 (39.84)	403 (15.87)	148 (5.83)	80 (3.15)	110 (4.33)	275 (10.83)	27 (60)
		50	2	913 (35.94)					225 (8.86)	26 (57)
		65	2½	1073 (42.24)					305 (12.01)	27 (60)
65	2½	50	2	1192 (46.93)	429 (16.89)	164 (6.46)	97 (3.82)	130 (5.12)	335 (13.19)	36 (79)
		65	2½	1073 (42.24)					275 (10.83)	37 (82)
		80	3	1180 (46.46)					328 (12.91)	38 (84)
80	3	65	2½	1302 (51.26)	456 (17.95)	186 (7.32)	108 (4.25)	140 (5.51)	378 (14.88)	45 (99)
		80	3	1180 (46.46)					296 (11.65)	44 (97)
		100	4	1448 (57.01)					430 (16.93)	46 (101)



If this connection is supplied with an EHEDG-certified device, the device nominal sizes must correspond with the connection nominal sizes!