

Safety Relays

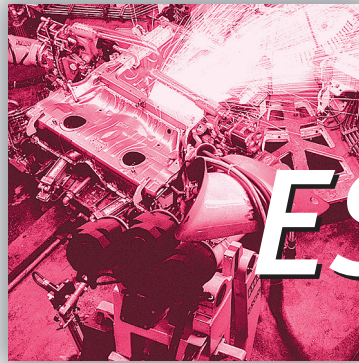

ESM ■



More than safety.



EUCHNER

More than safety.



Emil Euchner, the company's founder and inventor of the multiple limit switch, circa 1928.

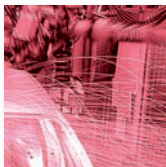

Around the world – the Swabian specialists in motion sequence control for mechanical and systems engineering.

EUCHNER's history began in 1940 with the establishment of an engineering office by Emil Euchner. Since that time, EUCHNER has been involved in the design and development of switchgear for controlling a wide variety of motion sequences in mechanical and systems engineering. In 1953, Emil Euchner founded EUCHNER + Co., a milestone in the company's history. In 1952, he developed the first multiple limit switch – to this day a symbol of the enterprising spirit of this family-owned company.

Automation – Safety – ManMachine

Today, our products range from electromechanical and electronic components to complex system solutions. With this wide range of products we can provide the necessary technologies to offer the right solution for special requirements – regardless of whether these relate to reliable and precise positioning or to components and systems for safety engineering in the automation sector.

EUCHNER products are sold through a world-wide sales network of competent partners. With our closeness to the customer and the guarantee of reliable solutions throughout the globe, we enjoy the confidence of customers all over the world.

Quality, reliability, precision

Quality, reliability and precision are the hallmarks of our corporate philosophy. They represent concepts and values to which we feel totally committed.

At EUCHNER, quality means that all our employees take personal responsibility for the company as a whole and, in particular, for their own field of work. This individual commitment to perfection results in products which are ideally tailored to the customers' needs and the requirements of the market. After all: our customers and their needs are the focus of all our efforts. Through efficient and effective use of resources, the promotion of personal initiative and courage in finding unusual solutions to the benefit of our customers, we ensure a high level of customer satisfaction. We familiarize ourselves with their needs, requirements and products and we learn from the experiences of our customers' own customers.

EUCHNER – More than safety.



Quality – made by EUCHNER

Safety Relays ESM

General Information	4
The ESM Modular Principle	4
Approvals	4
Explanation of Symbols	4
Safety Relays ESM	7
Safety relays ESM-BL.. and ESM-BA..	8
Safety relay time-delayed ESM-BT..	12
Safety relay 2-hand ESM-2H..	13
Contact expansion ESM-ES..	14
Contact expansion time-delayed ESM-TE..	15
Accessories	16
Technical Data	17
Appendix	26
Glossary	26
Connection examples ESM	26
Item Index	29

General information

For machines and systems that can produce a risk for people when in operation, the EU Machinery directive defines minimum requirements that are intended to reduce to a minimum the specific hazards and the related risks of accident.

If all sources of danger cannot be eliminated by design measures, appropriate protective measures must be taken. Using safety guards, such as fences or similar, it is intended to prevent people entering the danger area. If users need to have access to the danger area during operation, movable safety guards such as protective doors, flaps, etc., are used. This is the case, for example, for loading or unloading, troubleshooting, machine setup or cleaning work.

To safeguard this access area, safety switches with various principles of operation are used. These switches are designed to monitor the position of the safety guard and, when the safety guard is opened, to generate a signal which will safely interrupt the supply of power to the potentially hazardous parts of the system or which will ensure that the safety circuits are safely interrupted. The EUCHNER safety relays series ESM ensures that the safety circuits are interrupted. On the one hand they safely evaluate components connected such as

- ▶ mechanical safety switches with and without guard locking,
- ▶ non-contact safety switches,
- ▶ emergency stop controls,
- ▶ electro-sensitive protective equipment, etc.

while on the other hand they safely shut down potentially hazardous machine functions.

The safety relays impress with their compact DIN rail housing and their suitability for applications up to safety category 4 in accordance with EN ISO 13849-1.

The ESM modular principle

The majority of modules in the safety relay series ESM are installed in a housing that is only 22.5 mm wide. Various safety relays are available to which contact expansions can be added on the output side. The contact expansions can be non-time-delay or time-delayed. The advantage of this modular principle is that only a few devices are required to be able to realize a large number of different safety evaluations.

The relays can be operated with various types of starting. The devices can be started manually or automatically using suitable wiring. The manual start can also monitor the start button.

Using suitable wiring it is also possible to integrate a feedback circuit such that safety-related parts of a machine or system downstream can also be monitored.



In the ESM series the majority of the devices are available with a variety of input voltage ranges.

Approvals

To demonstrate conformity, the Machinery directive also includes the possibility of type examination. Although all relevant standards are taken into account during development, we have all our switchgear subjected to additional type examinations by a notified body.





Furthermore, numerous items of switchgear are listed by Underwriters Laboratories (UL). These items of switchgear can be used in countries in which this listing is required. The approval symbols on the individual pages of the catalog indicate which body tested the switchgear.

With the aid of the approval symbols listed below you can quickly see which approvals are available for the related switchgear:



	Switches with this symbol are approved by Underwriters Laboratories (UL)
	Switches with this symbol are approved by TÜV Rheinland

Explanation of symbols

Connection options

	Suitable for the connection of emergency stop
	Suitable for the connection of safety switches according to EN 1088
	Suitable for the connection of electro-sensitive protective equipment, e. g. light curtains
	Suitable for the connection of 2-hand circuits

Fault detection

	Short circuit is detected
	Ground fault is detected
	Earth fault is detected

Time-delay

	Safety contacts switch time-delayed
---	-------------------------------------

Safety category

**Cat.
3**

Suitable up to category 3 according to EN ISO 13849-1

**Cat.
4**

Suitable up to category 4 according to EN ISO 13849-1

Stop category

**STOP
0**

Immediate shutdown
stop category 0 according to EN 60204-1

**STOP
1**

Time-delayed shutdown
stop category 1 according to EN 60204-1

Technical data



Mechanical data



Electrical data

Selection table for safety relays ESM

Safety relays																		
BL	Non-time-delay category 3																	
BA	Non-time-delay category 4																	
BT	Time-delay category 3/non-time-delay category 4																	
2H	2-hand requirement level III C according to EN 574, category 4																	
Contact expansion																		
ES	Non-time-delay category 4																	
TE	Time-delay category 4																	
Category according to EN ISO 13849-1																		
K	Category according to EN ISO 13849-1																	
Enable path																		
SU	Safety contacts non-time-delay																	
SV	Safety contacts time-delay																	
M	Auxiliary contacts																	
Relay start																		
A	Automatic start																	
M	Start button																	
U	Monitored start button																	
Monitoring																		
R	Feedback loop																	
Q	Short circuit monitoring																	
E	Earth fault monitoring																	
M	Ground fault monitoring																	

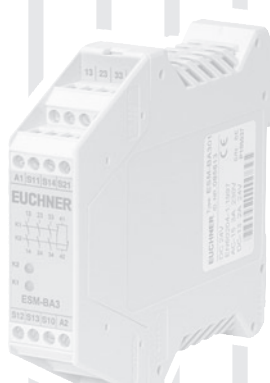

Devices																		
BL	BA	BT	2H	ES	TE	K	Outputs			Start			Monitoring				Page	
BL	BA	BT	2H	ES	TE	K	SU	SV	M	A	M	U	R	Q	E	M	Page	
●						3	2			●	●		●				8	
	●					4	2			●	●	●	●		●	●	9	
	●					4	3		1	●	●	●	●	●	●	●	10	
	●					4	7		4	●	●	●	●	●	●	●	11	
		●				4/3	1	3		●	●	●	●	●	●	●	12	
		●				4/3	2	2		●	●	●	●	●	●	●	12	
		●				4/3	3	1		●	●	●	●	●	●	●	12	
			●			4	2					●	●	●	●	●	13	
				●		4	3		1						●	●	14	
					●	3		3	1						●	●	15	

Safety relays ESM-BL.. and ESM-BA..



- ▶ ESM-BL.. up to category 3 according to EN ISO 13849-1
- ▶ ESM-BA.. up to category 4 according to EN ISO 13849-1
- ▶ LED status indicators
- ▶ 1-channel or 2-channel control
- ▶ Up to 7 redundant safety contacts
- ▶ Auxiliary contact optional
- ▶ Short circuit and earth fault/ground fault monitoring optional

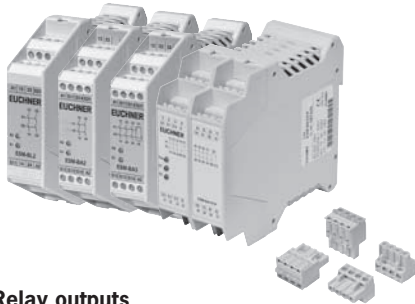

Relay outputs

The outputs are electrically decoupled and of redundant design

Connection options

By using suitable wiring the following functions can be selected:

- ▶ Relay start with automatic start or a start button
- ▶ Monitoring of downstream relays or contactors

On the series **ESM-BA..** safety relays, by using suitable wiring it is also possible to select:

- ▶ Simultaneity monitoring to monitor safety components over time
- ▶ Short circuit monitoring to detect short circuits between the connection cables and to shut down the outputs or prevent relay starting if necessary
- ▶ Earth fault/ground fault monitoring to detect short circuits between the connection cables and earth or ground and to shut down the outputs or prevent relay starting if necessary

Auxiliary contacts

The relays in the series ESM-BA3.. and ESMBA7... are available with electrically separate normally closed contacts and auxiliary contacts.

Connection terminals

Optional the ESM-BA... devices are also available as versions with plug-in connection terminals.

Safety relay ESM-BL..



Cat. 3 STOP 0

Dimension drawing

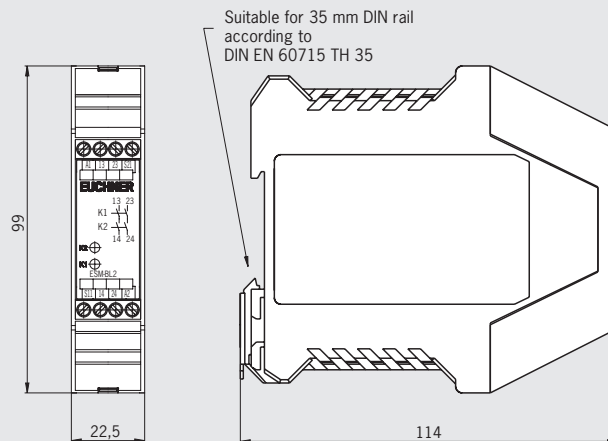

Block diagram

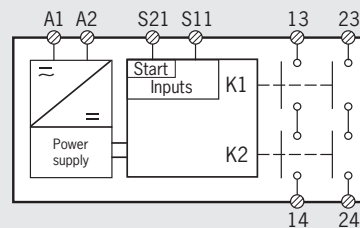

Technical data outputs

Parameter	Value		
Minimum switching current at 24 V DC	20 mA		
Maximum switching voltage	DC 24 V / AC 250 V		
Utilization category * according to EN 60947-5-1	U_e	I_e	ΣI_e
	AC-12	250 V	6 A
	AC-15	230 V	4 A
	DC-12	24 V	1.25 A
	DC-13	24 V	2 A

U_e = Switching voltage

I_e = Maximum switching current per contact

ΣI_e = Maximum switching current for all safety contacts (cumulative current)

* See page 26 for information about the utilization category

Ordering table

Series	Version	Outputs	AC/DC 24 V	AC 115 V	AC 230 V
ESM	BL Safety relay	2	085 607	085 608	085 609
		2 NO	ESM-BL201	ESM-BL202	ESM-BL203



Safety relay ESM-BA2..



Cat. 4 STOP 0

Dimension drawing

ESM-BA2...

Suitable for 35 mm DIN rail according to DIN EN 60715 TH 35

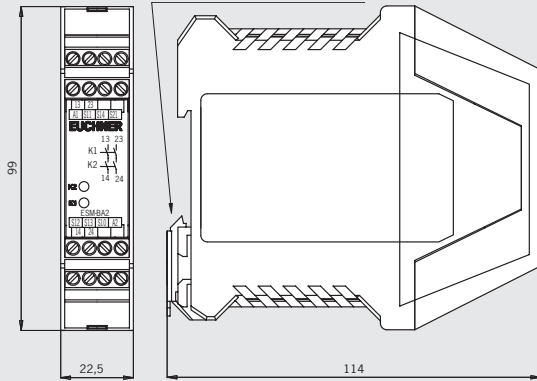

ESM-BA201P

Please order plug-in connection terminals separately

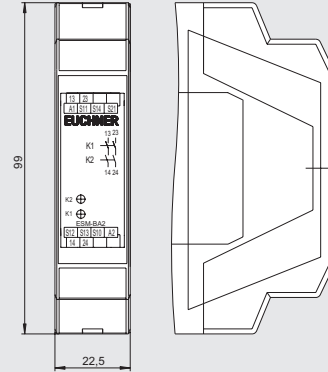

Block diagram

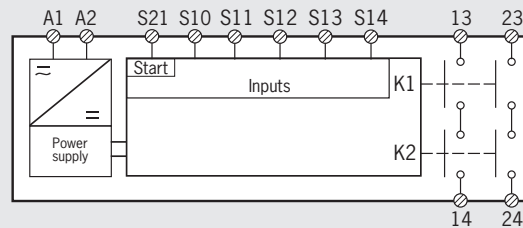

Technical data outputs

Parameter	Value		
Minimum switching current at 24 V DC	20 mA		
Maximum switching voltage	DC 24 V / AC 250 V		
Utilization category * according to EN 60947-5-1	U_e	I_e	ΣI_e
	AC-12	250 V	6 A
	AC-15	230 V	4 A
	DC-12	24 V	1.25 A
	DC-13	24 V	2 A
			12 A

U_e = Switching voltage

I_e = Maximum switching current per contact

ΣI_e = Maximum switching current for all safety contacts (cumulative current)

* See page 26 for information about the utilization category

Ordering table

Series	Version	Outputs	Connection	AC/DC 24 V	AC 115 V	AC 230 V
ESM	BA Safety relay	2 2 NO	Screw terminals	085 610 ESM-BA201	085 611 ESM-BA202	085 612 ESM-BA203
			Plug-in connection terminals ¹⁾	097 226 ESM-BA201P	-	-

1) Please order plug-in connection terminals separately (see page 16)





Safety relay ESM-BA3..



Cat. 4 STOP 0

Dimension drawing

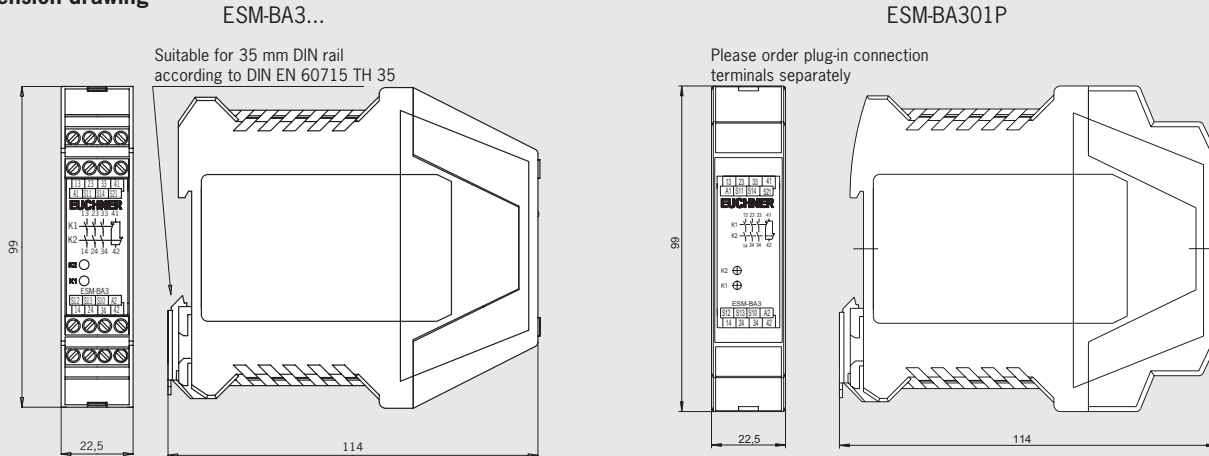

Block diagram

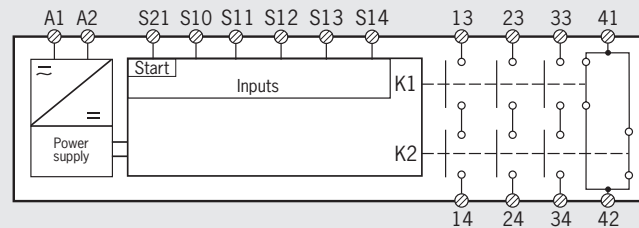

Technical data outputs

Parameter	Value		
Minimum switching current at 24 V DC	5 mA		
Maximum switching voltage	DC 24 V / AC 250 V		
Utilization category * according to EN 60947-5-1	U_e	I_e	Σ I_e
	AC-12	250 V	8 A
	AC-15	250V	3 A
	DC-12	50 V	8 A
	DC-13	24 V	3 A
			15 A ¹⁾

1) If several ESM-BA3.. are closely spaced under load, the max. cumulative current at an ambient temperature of 20 °C = 9 A; at 30 °C = 3 A; at 40 °C = 1 A. If these currents are exceeded, a spacing of 5 mm between the devices must be observed.

U_e = Switching voltage

I_e = Maximum switching current per contact

Σ I_e = Maximum switching current for all safety contacts (cumulative current)

* See page 26 for information about the utilization category

Ordering table

Series	Version	Outputs	Connection	AC/DC 24 V	AC 115 V	AC 230 V
ESM	BA Safety relay	3 3 NO + 1 NC	Screw terminals	085 613 ESM-BA301	087 412 ESM-BA302	087 413 ESM-BA303
			Plug-in connection terminals ¹⁾	097 230 ESM-BA301P	-	-

1) Please order plug-in connection terminals separately (see page 16)



Safety relay ESM-BA7..



Cat. 4 STOP 0

Dimension drawing

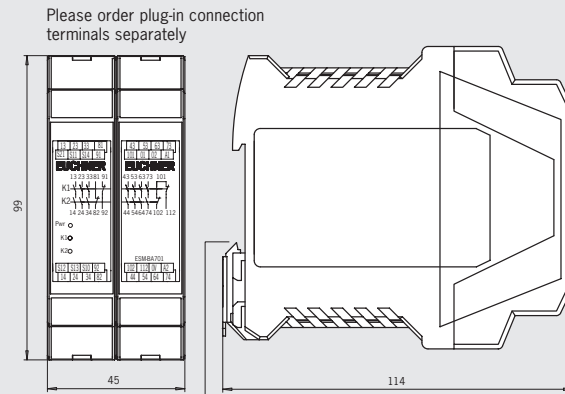

Suitable for 35 mm DIN rail according to DIN EN 60715 TH 35

Block diagram

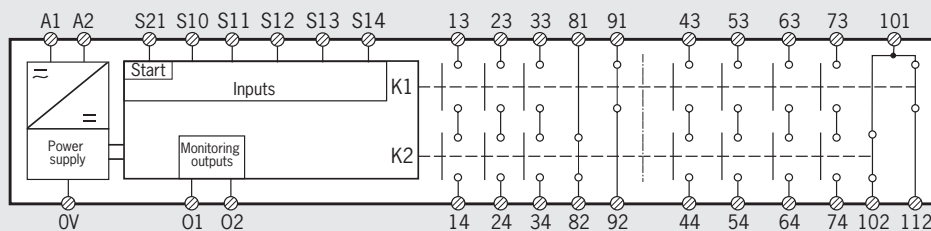

Technical data outputs

Parameter	Value		
Minimum switching current at 24 V DC	5 mA		
Maximum switching voltage	DC 50 V / AC 250 V		
Utilization category * according to EN 60947-5-1	U_e	I_e	ΣI_e
	AC-12	250 V	8 A
	AC-15	250 V	3 A
	DC-12	50 V	8 A
	DC-13	24 V	3 A
			35 A ¹⁾

1) With a housing distance of 10 mm. 20 A closely spaced at 40 °C

U_e = Switching voltage

I_e = Maximum switching current per contact

ΣI_e = Maximum switching current for all safety contacts (cumulative current)

* See page 26 for information about the utilization category

Ordering table

Series	Version	Outputs	Connection	AC/DC 24 V	AC 115 V	AC 230 V
ESM	BA Safety relay	7 7 NO + 4 NC	Plug-in connection terminals ¹⁾	097 225 ESM-BA701P	-	-

1) Please order plug-in connection terminals separately (see page 16). Two connection kits are required for devices from series ESM-BA701P.





Safety relay ESM-BT..

- ▶ Up to category 4 according to EN ISO 13849-1
- ▶ LED status indicators
- ▶ 1-channel or 2-channel control
- ▶ 4 redundant safety contact of which 1, 2 or 3 contacts time-delayed
- ▶ Time delay can be adjusted between 1 s and 30 s
- ▶ Short circuit and earth fault/ground fault monitoring



Relay outputs

The outputs are electrically decoupled and of redundant design

Connection options

By using suitable wiring the following functions can be selected:

- ▶ Relay start with automatic start, a start button or a monitored start button
- ▶ Monitoring of downstream relays or contactors
- ▶ Simultaneity monitoring to monitor safety components over time
- ▶ Short circuit monitoring to detect short circuits between the connection cables and to shut down the outputs or prevent relay starting if necessary
- ▶ Earth fault/ground fault monitoring to detect short circuits between the connection cables and earth or ground and to shut down the outputs or prevent relay starting if necessary

Time-delayed shutdown

The release time for the time-delay contacts can be set as required using a potentiometer on the safety relay.

Safety relay ESM-BT..



Cat. 4

STOP 0

STOP 1

Dimension drawing

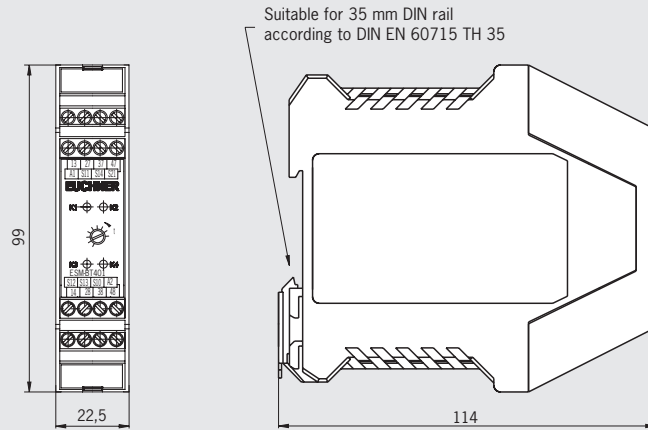

Block diagram

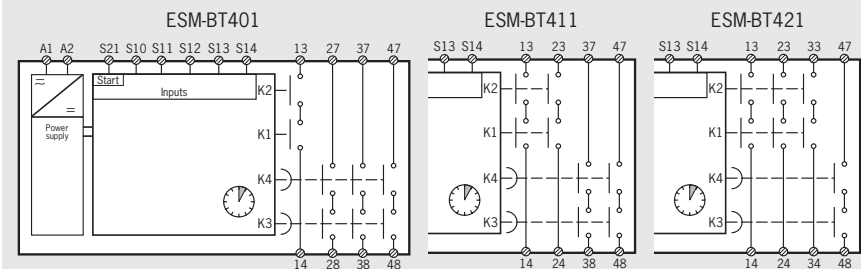

Technical data outputs

Parameter	Value		
Minimum switching current at 24 V DC	5 mA		
Maximum switching voltage	DC 50 V / AC 250 V		
Utilization category *	U_e	I_e	ΣI_e
according to EN 60947-5-1	AC-12	250 V	8 A
	AC-15	250 V	3 A
	DC-12	50 V	8 A
	DC-13	24 V	3 A

U_e = Switching voltage

I_e = Maximum switching current per contact

ΣI_e = Maximum switching current for all safety contacts (cumulative current)

* See page 26 for information about the utilization category

Ordering table

Series	Version	Outputs	AC/DC 24 V
ESM	BT Safety relay	401 1 NO non-time-delay 3 NO time-delay	090 818 ESM-BT401
		411 2 NO non-time-delay 2 NO time-delay	090 819 ESM-BT411
		421 3 NO non-time-delay 1 NO time-delay	090 820 ESM-BT421

Safety relay ESM-2H..



- ▶ Up to category 4 according to EN ISO 13849-1
- ▶ Requirement level III C according to EN 574
- ▶ LED status indicators
- ▶ Operation using 2-hand control
- ▶ 2 redundant safety contacts
- ▶ Short-circuit and earth fault/ground fault monitoring can be selected



Relay outputs

The outputs are electrically decoupled and of redundant design

Connection

- ▶ Two buttons each with one normally closed contact and one normally open contact that are monitored for simultaneity according to EN 574. In this way a high level of protection against tampering is provided.
- ▶ Short circuit monitoring to detect short circuits between the connection cables and to shut down the outputs or prevent relay starting if necessary
- ▶ Earth fault/ground fault monitoring to detect short circuits between the connection cables and earth or ground and to shut down the outputs or prevent relay starting if necessary

Connection option

By using suitable wiring the following function can be selected:

- ▶ Monitoring of downstream relays or contactors

Safety relay ESM-2H..



Cat. 4 STOP 0

Dimension drawing

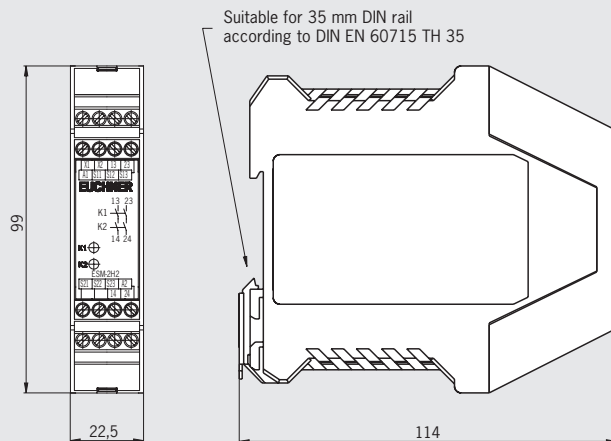

Block diagram

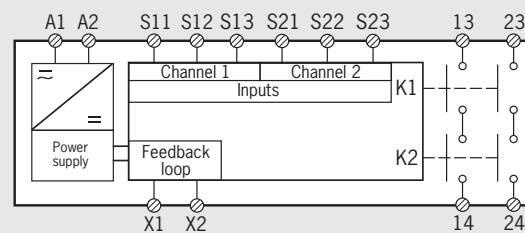

Technical data outputs

Parameter	Value		
Minimum switching current at 24 V DC	20 mA		
Maximum switching voltage	DC 24 V / AC 250 V		
Utilization category * according to EN 60947-5-1	U_e	I_e	ΣI_e
	AC-12	250 V	6 A
	AC-15	230 V	4 A
	DC-12	24 V	1.25 A
	DC-13	24 V	2 A

U_e = Switching voltage

I_e = Maximum switching current per contact

ΣI_e = Maximum switching current for all safety contacts (cumulative current)

* See page 26 for information about the utilization category

Ordering table

Series	Version	Outputs	AC/DC 24 V	AC 115 V	AC 230 V
ESM	2H Safety relay	2 2 NO	085 620 ESM-2H201	098 345 ESM-2H202	-

Contact expansion ESM-ES..

- ▶ Up to category 4 according to EN ISO 13849-1
- ▶ LED status indicators
- ▶ Control using safety relays
- ▶ 3 redundant safety contacts
- ▶ 1 auxiliary contact
- ▶ Earth fault/ground fault monitoring can be selected



Relay outputs

The outputs are electrically decoupled and of redundant design

Connection option

By using suitable wiring the following function can be selected:

- ▶ Earth fault/ground fault monitoring to detect short circuits between the connection cables and earth or ground and to shut down the outputs or prevent relay starting if necessary



Contact expansion ESM-ES..



Cat. 4 STOP 0

Dimension drawing

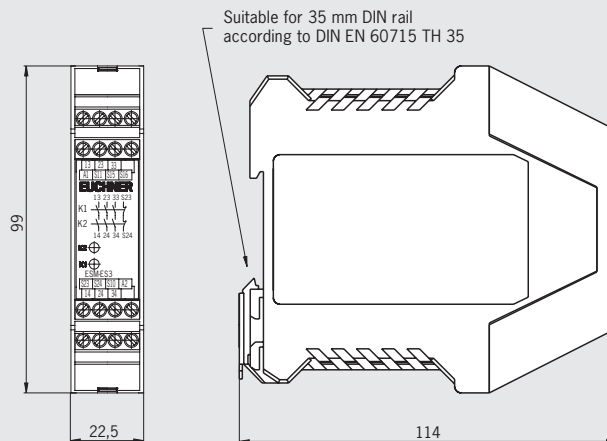

Block diagram

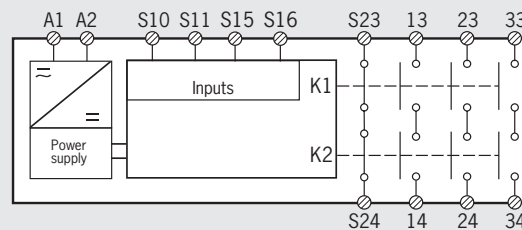

Technical data outputs

Parameter	Value			
Minimum switching current at 24 V DC	5 mA			
Maximum switching voltage	DC 50 V / AC 250 V			
Utilization category * according to EN 60947-5-1		U_e	I_e	ΣI_e
	AC-12	250 V	6 A	
	AC-15	230 V	4 A	
	DC-12	24 V	1.25 A	
	DC-13	24 V	2 A	10,5 A

U_e = Switching voltage

I_e = Maximum switching current per contact

ΣI_e = Maximum switching current for all safety contacts (cumulative current)

* See page 26 for information about the utilization category

Ordering table

Series	Version	Outputs	AC/DC 24 V	AC 115 V	AC 230 V
ESM	ES Contact expansion	3 3 NO + 1 NC	085 614 ESM-ES301	085 615 ESM-ES302	085 616 ESM-ES303



Contact expansion ESM-TE..

- ▶ Up to category 3 according to EN ISO 13849-1
- ▶ LED status indicators
- ▶ Control using safety relays
- ▶ 3 redundant time-delayed safety contacts
- ▶ Time delay can be adjusted between 1 s and 30 s
- ▶ Fixed time-delay of 0,5 s optional
- ▶ 1 auxiliary contact
- ▶ Earth fault/ground fault monitoring can be selected



Relay outputs

The outputs are electrically decoupled and of redundant design

Connection option

By using suitable wiring the following function can be selected:

- ▶ Earth fault/ground fault monitoring to detect short circuits between the connection cables and earth or ground and to shut down the outputs or prevent relay starting if necessary

Time-delayed shutdown

The release time for the time-delay contacts can be set as required using a potentiometer on the safety relay.

Contact expansion ESM-TE..



Cat. 3 STOP 1

Dimension drawing

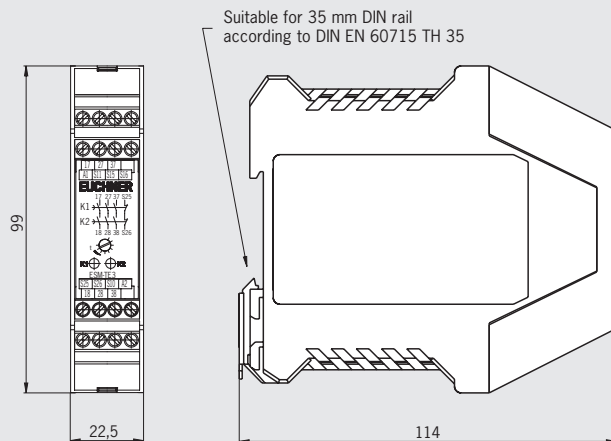

Block diagram

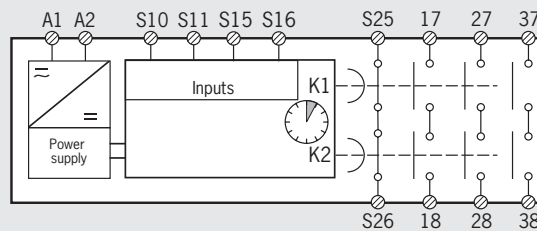

Technical data outputs

Parameter	Value			
Minimum switching current at 24 V DC	5 mA			
Maximum switching voltage	DC 50 V / AC 250 V			
Utilization category * according to EN 60947-5-1	U_e	I_e	ΣI_e	
	AC-12	250 V	6 A	10.5 A
	AC-15	250 V	4 A	
	DC-12	24 V	1.25 A	
DC-13	24 V	2 A		

U_e = Switching voltage

I_e = Maximum switching current per contact

ΣI_e = Maximum switching current for all safety contacts (cumulative current)

* See page 26 for information about the utilization category

Ordering table

Series	Version	Outputs	Time-delay	AC/DC 24 V	AC 115 V	AC 230 V
ESM	TE Contact expansion	3 3 NO + 1 NC time-delayed	adjustable	085 617	085 618	085 619
			1 s ... 30 s	ESM-TE301	ESM-TE302	ESM-TE303
			fixed	097 223	-	-
			0.5 s	ESM-TE301-05S		



Accessories for safety system ESM

- ▶ **Connection set ESM-P with screw terminals or spring terminals**

Important: One connection kit is required, depending on the device (see information on the corresponding product page). Two connection kits are required for devices from series ESM-BA701P.

Ordering table

Designation	Description	Cat. No.
Connection set ESM-P with screw terminals	Comprising: 4 plug-in screw terminals (can be coded) 2 jumpers coding pins	097 194 ESM-F-AK4
Connection set ESM-P with spring terminals	Comprising: 4 plug-in spring terminals (can be coded) 2 jumpers coding pins	097 195 ESM-F-KK4

Overview safety relays ESM

Safety relays ESM						
BL						Non-time-delay category 3
	BA					Non-time-delay category 4
		BT				Time-delay category 3/non-time-delay category 4
			2H			2-hand requirement level III C according to EN 574, category 4
Contact expansions ESM						
				ES		Non-time-delay category 4
					TE	Time-delay category 4

Safety relay ESM						Page
BL	BA	BT	2H	ES	TE	
●						18
	●					19
		●				22
			●			23
				●		24
					●	25

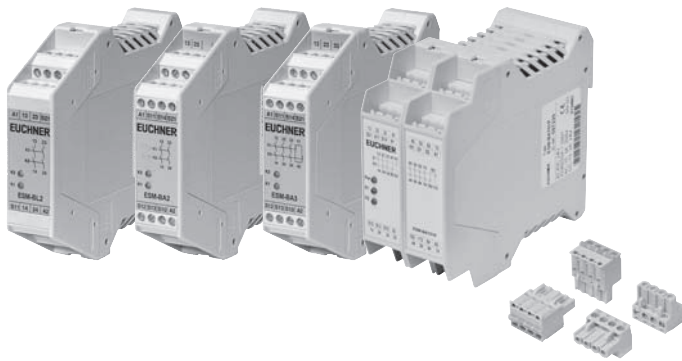

Housing						
Parameter	Value					Unit
Housing material	Polyamide PA6.6					
Dimensions	114 x 99 x 22.5 (ESM-BA7... 114 x 99 x 45)					mm
Weight	Approx. 0.25 (ESM-BA7... Approx. 0.35)					kg
Connection type	Connection terminals					
Connection terminals	0.14 ... 2.5					mm ²
Ambient temperature	Base	ESM-BL2.. ESM-BA2..	ESM-BA3.. ESM-BA7..	ESM-BT4..	ESM-2H2..	
	at U _B = 24 V DC	-15 ... +60	-15 ... +40	-15 ... +40	-15 ... +60	°C
	at U _B = 115/230 V AC	-15 ... +40	-15 ... +40	-	-15 ... +40	°C
	Contact expansion	ESM-ES3.. ESM-TE3...				
	at U _B = 24 V DC	-15 ... +60				°C
	at U _B = 115/230 V AC	-15 ... +40				°C
Degree of protection acc. to EN 60529	IP 20					
Degree of contamination	2					
Mounting	35 mm DIN rail acc. to DIN EN 60715 TH 35					
Life	Base	ESM-BL2.. ESM-BA2..	ESM-BA7..	ESM-BT4..	ESM-2H2..	
		ESM-BA3..				
	Mechanical	1 x 10 ⁷	1 x 10 ⁶	1 x 10 ⁶	1 x 10 ⁷	Operating cycles
	Electrical	1 x 10 ⁵	1 x 10 ⁶	1 x 10 ⁵	1 x 10 ⁵	Operating cycles
	Contact expansion	ESM-ES3.. ESM-TE3...				
	Mechanical	1 x 10 ⁷				Operating cycles
	Electrical	1 x 10 ⁵				Operating cycles

Connection ESM-BL2..						
Parameter	Value					Unit
Operating voltage	ESM-BL201	24 ± 10% ¹⁾				V AC/DC
	ESM-BL202	115 ± 10%				V AC
	ESM-BL203	230 ± 10%				V AC
Reverse polarity protection	On ESM-BL201					
Rated supply frequency	50 ... 60					Hz
Power consumption	Approx. 3 VA / 1.8 W					
Control voltage for start button	18.6 ... 26					V DC
Control cable length (cross-section 0.75 mm ²)	Max. 1000					m
Control current for start button	Approx. 40					mA
External contact fuses (safety circuit) according to EN 60269-1	10 A gG (T4A / F6A)					
Test voltage (control voltage/contacts)	2.5					kV
Rated impulse withstand voltage, Leakage path and air gap acc. to DIN VDE 0110-1	4					kV
Rated insulation voltage	250					V
Overvoltage category acc. to DIN VDE 0110-1	3					
Safety contacts	2 NO contacts (redundant)					
Minimum switching current at 24 V DC	20					mA
Maximum switching voltage	24					V DC
	250					V AC
Breaking capacity acc. to \mathcal{U}	6 A 250 V AC 2 A 24 V DC					
Utilization category ²⁾ according to EN 60947-5-1		U_e	I_e	Σ I_e		
	AC-12	250 V	6 A	12 A		
	AC-15	230 V	4 A			
	DC-12	24 V	1.25 A			
DC-13	24 V	2 A				
LED indicators	2, status display for relays K1 and K2					
Reliability figures according to EN ISO 13849-1						
Category	3					
Performance Level PL	d					

1) All the electrical connections must either be isolated from the mains supply by a safety transformer according to EN 61558-2-6 with limited output voltage in the event of a fault, or by other equivalent isolation measures.

2) See page 26 for information about the utilization category.

U_e = Switching voltage I_e = Maximum switching current per contact

Σ I_e = Maximum switching current for all safety contacts (cumulative current)

Connection ESM-BA2..



Parameter	Value	Unit		
Operating voltage	ESM-BA201	24 ± 10% ¹⁾		
	ESM-BA202	115 ± 10%		
	ESM-BA203	230 ± 10%		
Reverse polarity protection	On ESM-BA201			
Rated supply frequency	50 ... 60	Hz		
Power consumption	Approx. 3 VA / 1.8 W			
Control voltage for start button	18.6 ... 26	V DC		
Control cable length (cross-section 0.75 mm ²)	Max. 1000	m		
Control current for start button	Approx. 40	mA		
External contact fuses (safety circuit) according to EN 60269-1	10 A gG (T4A / F6A)			
Test voltage (control voltage/contacts)	2.5	kV		
Rated impulse withstand voltage, Leakage path and air gap acc. to DIN VDE 0110-1	4	kV		
Rated insulation voltage	250	V		
Overvoltage category acc. to DIN VDE 0110-1	3			
Safety contacts	2 NO contacts (redundant)			
Minimum switching current at 24 V DC	20	mA		
Maximum switching voltage	24	V DC		
	250	V AC		
Breaking capacity acc. to	6 A 250 V AC 2 A 24 V DC			
Utilization category ²⁾ according to EN 60947-5-1	U_e	I_e	Σ I_e 12 A	
	AC-12	250 V		6 A
	AC-15	230 V		4 A
	DC-12	24 V		1.25 A
	DC-13	24 V	2 A	
LED indicators	2, status display for relays K1 and K2			
Reliability figures according to EN ISO 13849-1				
Category	4			
Performance Level PL	e			

1) All the electrical connections must either be isolated from the mains supply by a safety transformer according EN 61558-2-6 with limited output voltage in the event of a fault, or by other equivalent isolation measures.

2) See page 26 for information about the utilization category.

U_e = Switching voltage I_e = Maximum switching current per contact



Σ I_e = Maximum switching current for all safety contacts (cumulative current)

Connection ESM-BA3..



Parameter		Value	Unit
Operating voltage	ESM-BA301	24 ± 10% ¹⁾	V AC/DC
	ESM-BA302	115 ± 10%	V AC
	ESM-BA303	230 ± 10%	V AC
Reverse polarity protection		On ESM-BA301	
Rated supply frequency		50 ... 60	Hz
Power consumption		Approx. 7	VA
Control voltage for start button		18.6 ... 26	V DC
Control cable length (cross-section 0.75 mm ²)		Max. 1000	m
Control current for start button		Approx. 60	mA
External contact fuses (safety circuit) according to EN 60269-1		10 A gG (T6A / F8A)	
Test voltage (control voltage/contacts)		2.5	kV
Rated impulse withstand voltage,		4	kV
Leakage path and air gap acc. to DIN VDE 0110-1			
Rated insulation voltage		250	V
Overvoltage category acc. to DIN VDE 0110-1		3	
Safety contacts		3 NO contacts (redundant)	
Cumulative current of all contacts acc. to \mathcal{U}		Max. 15	A
Minimum switching current at 24 V DC		5	mA
Maximum switching voltage		50	V DC
		250	V AC
Breaking capacity acc. to \mathcal{U}	ESM-BA301	8 A 250 V AC / 2 A 24 V DC	
	ESM-BA302		
	ESM-BA303	8 A 250 V AC / 3 A 24 V DC	
Utilization category ²⁾ according to EN 60947-5-1		U_e	I_e
	AC-12	250 V	8 A ⁴⁾
	AC-15	250 V	3 A
	DC-12	50 V	8 A ⁴⁾
	DC-13	24 V	3 A
			ΣI_e
			15 A ³⁾
LED indicators		2, status display for relays K1 and K2	
Auxiliary contact		1 NC contact	
Maximum switching voltage		24	V DC
		250	V AC
Breaking capacity acc. to \mathcal{U}	ESM-BA301	2 A 250 V AC / 1.5 A 24 V DC	
	ESM-BA302		
	ESM-BA303	2 A 250 V AC / 2 A 24 V DC	
Utilization category ²⁾ according to EN 60947-5-1		U_e	I_e
	AC-12	250 V	2 A
	AC-15	250 V	1.5 A
	DC-12	50 V	2 A
	DC-13	24 V	1.25 A
Reliability figures according to EN ISO 13849-1			
Category		4	
Performance Level PL		e	

- All the electrical connections must either be isolated from the mains supply by a safety transformer according to EN 61558-2-6 with limited output voltage in the event of a fault, or by other equivalent isolation measures.
 - See page 26 for information about the utilization category.
 - If several ESM-BA3.. are closely spaced under load, the max. cumulative current at an ambient temperature of 20 °C = 9 A; at 30 °C = 3 A; at 40 °C = 1 A. If these currents are exceeded, a spacing of 5 mm between the devices must be observed.
 - For resistive load.
- U_e = Switching voltage I_e = Maximum switching current per contact ΣI_e = Maximum switching current for all safety contacts (cumulative current)

Connection ESM-BA7.. 				
Parameter	Value		Unit	
Operating voltage	24 ± 10% ¹⁾		V AC/DC	
Reverse polarity protection	Yes			
Rated supply frequency	50 ... 60		Hz	
Power consumption	Approx. 7		VA	
Control voltage for start button	18.6 ... 26		V DC	
Control cable length (cross-section 0.75 mm ²)	Max. 1000		m	
Control current for start button	Approx. 100		mA	
External contact fuses (safety circuit) according to EN 60269-1	10 A gG (T6A / F8A)			
Test voltage (control voltage/contacts)	2.5		kV	
Rated impulse withstand voltage, Leakage path and air gap acc. to DIN VDE 0110-1	4		kV	
Rated insulation voltage	250		V	
Overvoltage category acc. to DIN VDE 0110-1	3			
Safety contacts	7 NO contacts (redundant)			
Minimum switching current at 24 V DC	5		mA	
Maximum switching voltage	50		V DC	
	250		V AC	
Breaking capacity acc. to  (per contact)	8 A 250 V AC 2 A 24 V DC			
Utilization category ²⁾ according to EN 60947-5-1	U_e	I_e	Σ I_e	
	AC-12	250 V	8 A	35 A ³⁾
	AC-15	250 V	3 A	
	DC-12	50 V	8 A	
	DC-13	24 V	3 A	
LED indicators	2, status display for relays K1 and K2			
Auxiliary contacts	4 NO contacts			
Maximum switching voltage	50		V DC	
	250		V AC	
Breaking capacity acc. to 	2 A 250 V AC 1.5 A 24 V DC			
Utilization category ²⁾ according to EN 60947-5-1	U_e	I_e		
	AC-12	250 V	8 A	
	AC-15	250 V	3 A	
	DC-12	50 V	8 A	
	DC-13	24 V	3 A	
Monitoring outputs	2 semiconductor outputs			
Semiconductor output current	Max. 30		mA	
Semiconductor output voltage	24		V DC	
Reliability figures according to EN ISO 13849-1				
Category	4			
Performance Level PL	e			

1) All the electrical connections must either be isolated from the mains supply by a safety transformer according to EN 61558-2-6 with limited output voltage in the event of a fault, or by other equivalent isolation measures.

2) See page 26 for information about the utilization category.

3) With a housing distance of 10 mm. 20 A closely spaced at 40 °C.

U_e = Switching voltage I_e = Maximum switching current per contact

Σ I_e = Maximum switching current for all safety contacts (cumulative current)



Connection ESM-BT4..



Parameter	Value	Unit		
Operating voltage	24 ± 10% ¹⁾	V AC/DC		
Reverse polarity protection	Yes			
Rated supply frequency	50 ... 60	Hz		
Power consumption	Approx. 4.6	W		
Time-delay range	1 ... 30	s		
Control voltage for start button	18.6 ... 26	V DC		
Control cable length (cross-section 0.75 mm ²)	Max. 1000	m		
Control current for start button	Approx. 190	mA		
External contact fuses (safety circuit) according to EN 60269-1	10 A gG (T6A / F8A)			
Test voltage (control voltage/contacts)	2.5	kV		
Rated impulse withstand voltage, Leakage path and air gap acc. to DIN VDE 0110-1	4	kV		
Rated insulation voltage	250	V		
Overvoltage category acc. to DIN VDE 0110-1	3			
Safety contacts	4 NO contacts (redundant)			
Cumulative current of all contacts acc. to \mathcal{U}	Max. 15	A		
Minimum switching current at 24 V DC	5	mA		
Maximum switching voltage	50	V DC		
	250	V AC		
Breaking capacity acc. to \mathcal{U} (per contact)	6 A 250 V AC			
	2 A 24 V DC			
Utilization category ²⁾ according to EN 60947-5-1	U_e	I_e	Σ I_e	
	AC-12	250 V	8 A ⁴⁾	15 A ³⁾
	AC-15	250 V	3 A	
	DC-12	50 V	8 A ⁴⁾	
DC-13	24 V	3 A		
LED indicators	4, status display for relays K1 to K4			
Reliability figures according to EN ISO 13849-1				
Category	4 (non-time-delay) / 3 (time-delay)			
Performance Level PL	e			

1) All the electrical connections must either be isolated from the mains supply by a safety transformer according to EN 61558-2-6 with limited output voltage in the event of a fault, or by other equivalent isolation measures.

2) See page 26 for information about the utilization category.

3) With a housing distance of 5 mm. 9 A closely spaced at 40 °C.

4) For resistive load.

U_e = Switching voltage

I_e = Maximum switching current per contact

Σ I_e = Maximum switching current for all safety contacts (cumulative current)

Connection ESM-2H2..



Parameter	Value		Unit
Operating voltage	ESM-2H201	$24 \pm 10\%$ ¹⁾	V AC/DC
	ESM-2H202	$115 \pm 10\%$	V AC
Reverse polarity protection	Yes		
Rated supply frequency	50 ... 60		Hz
Power consumption	Approx. 4		VA
Control voltage at buttons S12 - S13 and S22 - S23	18.6 ... 26		V DC
Control cable length (cross-section 0.75 mm ²)	Max. 1000		m
Control current for both buttons	20 each		mA
External contact fuses (safety circuit) according to EN 60269-1	10 A gG (T4A / F6A)		
Test voltage (control voltage/contacts)	2.5		kV
Rated impulse withstand voltage, Leakage path and air gap acc. to DIN VDE 0110-1	4		kV
Rated insulation voltage	250		V
Overvoltage category acc. to DIN VDE 0110-1	3		
Safety contacts	2 NO contacts (redundant)		
Synchronization time	Max. 0.5		s
Release time for the safety relay (response time)	Max. 20		ms
Minimum switching current at 24 V DC	20		mA
Maximum switching voltage	24		V DC
	250		V AC
Breaking capacity acc. to \mathcal{U}	6 A 250 V AC		
	2 A 24 V DC		
Utilization category ²⁾ according to EN 60947-5-1	U_e	I_e	Σ I_e
	AC-12	250 V	6 A ³⁾
	AC-15	230 V	4 A
	DC-12	24 V	1.25 A ³⁾
	DC-13	24 V	2 A
LED indicators	2, status display for relays K1 and K2		
Reliability figures according to EN ISO 13849-1			
Category	4		
Performance Level PL	e		

1) All the electrical connections must either be isolated from the mains supply by a safety transformer according EN 61558-2-6 with limited output voltage in the event of a fault, or by other equivalent isolation measures.

2) See page 26 for information about the utilization category.

3) For resistive load.

U_e = Switching voltage

I_e = Maximum switching current per contact

Σ I_e = Maximum switching current for all safety contacts (cumulative current)

Connection ESM-ES3..



Parameter	Value	Unit		
Operating voltage	ESM-ES301	24 ± 10% ¹⁾		
	ESM-ES302	115 ± 10%		
	ESM-ES303	230 ± 10%		
Reverse polarity protection	On ESM-ES301			
Rated supply frequency	50 ... 60	Hz		
Power consumption	Approx. 4 VA / 2 W			
Control voltage at inputs	18.6 ... 26	V DC		
Control cable length (cross-section 0.75 mm ²)	Max. 1000	m		
External contact fuses (safety circuit) according to EN 60269-1	10 A gG (T4A / F6A)			
Test voltage (control voltage/contacts)	2.5	kV		
Rated impulse withstand voltage, Leakage path and air gap acc. to DIN VDE 0110-1	4	kV		
Rated insulation voltage	250	V		
Overvoltage category acc. to DIN VDE 0110-1	3			
Cumulative current of all contacts acc. to \mathcal{U}	Max. 10.5	A		
Safety contacts	3 NO contacts (redundant)			
Minimum switching current at 24 V DC	20	mA		
Maximum switching voltage	50	V DC		
	250	V AC		
Breaking capacity acc. to \mathcal{U} (per contact)	6 A 250 V AC 2 A 24 V DC			
Utilization category ²⁾ according to EN 60947-5-1	U_e	I_e	Σ I_e	
	AC-12	250 V	6 A ³⁾	12 A
	AC-15	230 V	4 A	
	DC-12	24 V	1.25 A ³⁾	
DC-13	24 V	2 A		
LED indicators	2, status display for relays K1 and K2			
Auxiliary contact	1 NC contact			
Continuous current max.	500 ⁴⁾	mA		
Maximum switching voltage	24	V AC/DC		
Reliability figures according to EN ISO 13849-1				
Category	4			
Performance Level PL	e			

1) All the electrical connections must either be isolated from the mains supply by a safety transformer according EN 61558-2-6 with limited output voltage in the event of a fault, or by other equivalent isolation measures.



2) See page 26 for information about the utilization category.

3) For resistive load.

4) As monitoring contact for safety relay.

U_e = Switching voltage I_e = Maximum switching current per contact

Σ I_e = Maximum switching current for all safety contacts (cumulative current)

Connection ESM-TE3..			
Parameter		Value	Unit
Operating voltage	ESM-TE301	24 ± 10% ¹⁾	V AC/DC
	ESM-TE302	115 ± 10%	V AC
	ESM-TE303	230 ± 10%	V AC
Reverse polarity protection		On ESM-TE301	
Rated supply frequency		50 ... 60	Hz
Power consumption		Approx. 4	VA
Time-delay range		1 ... 30	s
Fixed time-delay	ESM-TE301-05S	0.5 ²⁾	s
Control voltage at inputs		18.6 ... 26	V DC
Control cable length (cross-section 0.75 mm ²)		Max. 1000	m
External contact fuses (safety circuit) according to EN 60269-1		10 A gG (T4A / F6A)	
Test voltage (control voltage/contacts)		2.5	kV
Rated impulse withstand voltage, Leakage path and air gap acc. to DIN VDE 0110-1		4	kV
Rated insulation voltage		250	V
Overvoltage category acc. to DIN VDE 0110-1		3	
Cumulative current of all contacts acc. to 		Max. 10.5	A
Safety contacts		3 NO contacts (redundant)	
Minimum switching current at 24 V DC		5	mA
Maximum switching voltage		50	V DC
		250	V AC
Breaking capacity acc. to  (per contact)		6 A 250 V AC	
		2 A 24 V DC	
Utilization category ³⁾ according to EN 60947-5-1		U_e	I_e
		250 V	6 A ⁴⁾
		250 V	4 A
		24 V	1.25 A ⁴⁾
		24 V	2 A
LED indicators		2, status display for relays K1 and K2	
Auxiliary contacts		1 NC contact	
Continuous current max.		500 ⁵⁾	mA
Maximum switching voltage		24	V DC
Reliability figures according to EN ISO 13849-1			
Category		3	
Performance Level PL		d	

1) All the electrical connections must either be isolated from the mains supply by a safety transformer according to EN 61558-2-6 with limited output voltage in the event of a fault, or by other equivalent isolation measures.

2) ESM-TE301-05S without potentiometer.

3) See page 26 for information about the utilization category.

4) For resistive load.

4) As monitoring contact for safety relay.

U_e = Switching voltage I_e = Maximum switching current per contact

Σ I_e = Maximum switching current for all safety contacts (cumulative current)

Glossary

Feedback loop

Components connected downstream of the safety relay can be monitored for correct function. For this purpose normally closed contacts on these components are integrated into the feedback loop on the relay.

Relay start

After the relay has switched off due to a request from a safety component connected, the relay must be re-started. On this topic please pay attention to section 5.2.2 of EN ISO 13849-1:2008.

► Automatic start

The relay switches on automatically as soon as the safety component connected changes back to the safe state.

► Manual start

The relay is started by actuating a button. First the safe state of the safety components connected must be re-established.

► Monitored, manual start

The relay is started by actuating a button. The button is monitored for jamming or possible tampering. Prior to starting the relay the safe state of the safety components connected must be re-established.

Single-channel safety circuit

A single positively driven contact in the safety component is connected to the relay. This type of connection is suitable for categories 1 or 2 according to EN ISO 13849-1.

Dual-channel safety circuit

Two contacts of which at least one is a positively driven contact are connected to the relay. This type of connection is suitable for categories 3 or 4 according to EN ISO 13849-1.

Utilization category according to EN 60947-5-1 (excerpt)

Voltage type	Utilization category	Typical applications
AC	AC-12	Controlling resistive load and semiconductor load in input circuits of optocouplers
	AC-15	Controlling electromagnetic load (> 72 VA)
DC	DC-12	Controlling resistive load and semiconductor load in input circuits of optocouplers
	DC-13	Controlling electromagnetic loads with economy resistors in the circuit

Connection examples safety relays ESM

Safety relay ESM-BL..

Automatic start without integration of the feedback loop

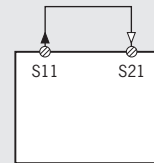

Manual start without integration of the feedback loop

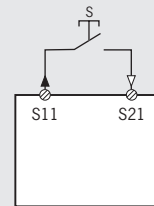

Automatic start with integration of the feedback loop

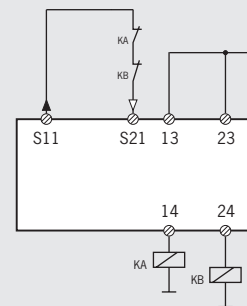

Manual start with integration of the feedback loop

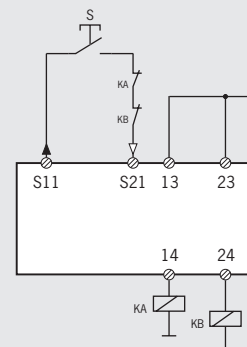

EMERGENCY STOP/safety circuit

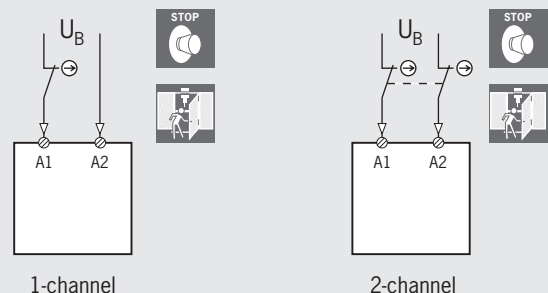

1-channel

2-channel

Safety relays ESM-BA../ESM-BT..

Monitored start without integration of the feedback loop

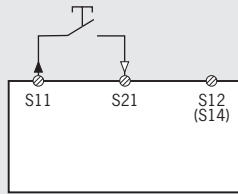

Un-monitored start without integration of the feedback loop

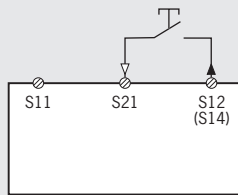

Automatic start without integration of the feedback loop

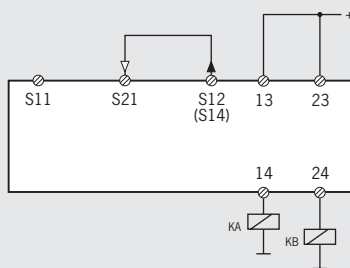

Monitored start with integration of the feedback loop

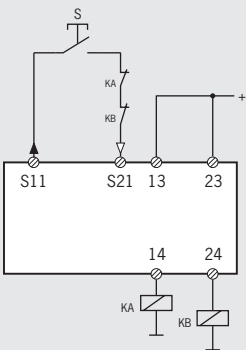

Un-monitored start with integration of the feedback loop

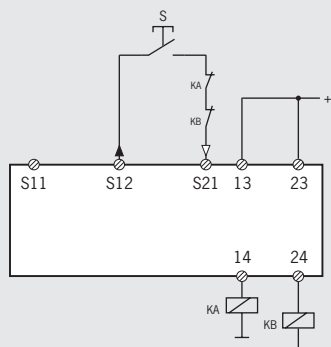

Automatic start with integration of the feedback loop

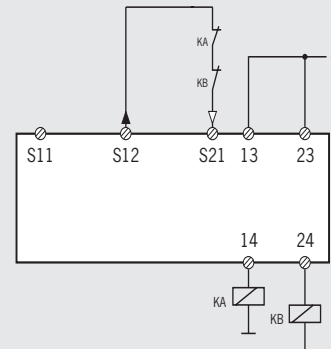

1-channel EMERGENCY STOP/safety circuit

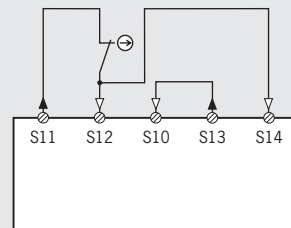

2-channel EMERGENCY STOP/safety circuit with ground fault/short circuit detection

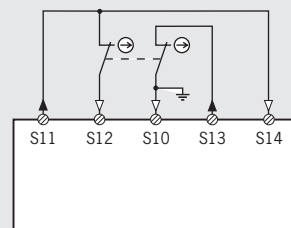

2-channel EMERGENCY STOP/safety circuit with connection for MGB, CES-AR and light curtains

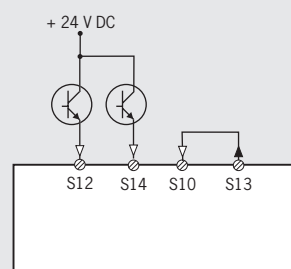

Safety relay ESM-2H2..

Monitoring a 2-hand control

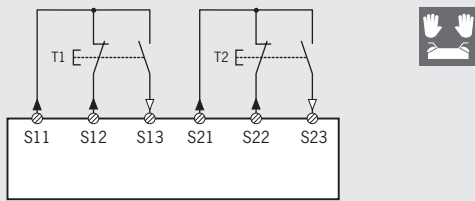

With integration of the feedback loop

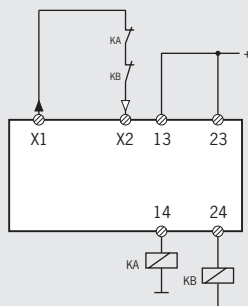

Without integration of the feedback loop

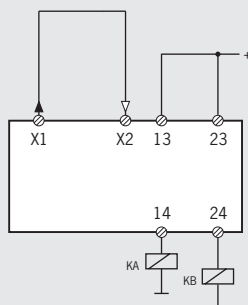

Safety contact expansion ESM-ES../ESM-TE..

Integration of the contact expansion

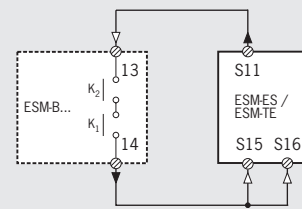

Connection of the contact expansion with automatic start and with integration of the feedback loop

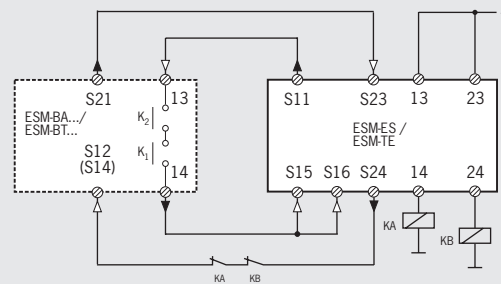

Connection of the contact expansion with manual start and with integration of the feedback loop

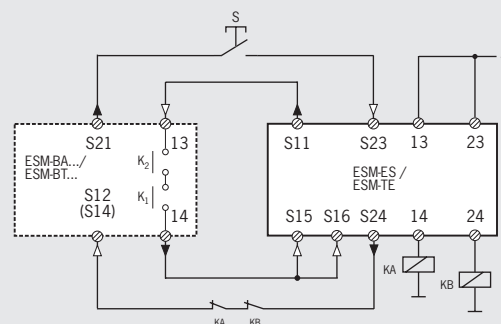

Index by item designation

Item	Order No.	Page
ESM-2H201	085 620	13
ESM-2H202	098 345	13
ESM-BA201	085 610	9
ESM-BA201P	097 226	9
ESM-BA202	085 611	9
ESM-BA203	085 612	9
ESM-BA301	085 613	10
ESM-BA301P	097 230	10
ESM-BA302	087 412	10
ESM-BA303	087 413	10
ESM-BA701P	097 225	11
ESM-BL201	085 607	8
ESM-BL202	085 608	8
ESM-BL203	085 609	8
ESM-BT401	090 818	12
ESM-BT411	090 819	12
ESM-BT421	090 820	12
ESM-ES301	085 614	14
ESM-ES302	085 615	14
ESM-ES303	085 616	14
ESM-F-AK4	097 194	16
ESM-F-KK4	097 195	16
ESM-TE301	085 617	15
ESM-TE301-05S	097 223	15
ESM-TE302	085 618	15
ESM-TE303	085 619	15

Index by order number

Order No.	Item	Page
085 607	ESM-BL201	8
085 608	ESM-BL202	8
085 609	ESM-BL203	8
085 610	ESM-BA201	9
085 611	ESM-BA202	9
085 612	ESM-BA203	9
085 613	ESM-BA301	10
085 614	ESM-ES301	14
085 615	ESM-ES302	14
085 616	ESM-ES303	14
085 617	ESM-TE301	15
085 618	ESM-TE302	15
085 619	ESM-TE303	15
085 620	ESM-2H201	13
087 412	ESM-BA302	10
087 413	ESM-BA303	10
090 818	ESM-BT401	12
090 819	ESM-BT411	12
090 820	ESM-BT421	12
097 194	ESM-F-AK4	16
097 195	ESM-F-KK4	16
097 223	ESM-TE301-05S	15
097 225	ESM-BA701P	11
097 226	ESM-BA201P	9
097 230	ESM-BA301P	10
098 345	ESM-2H202	13

International Representatives

Australia

Micromax Sensors & Automation
Unit 2, 106-110 Beaconsfield Street
Silverwater, NSW 2128
Tel. +61-2-8748-2800
Fax +61-2-9648-2345
info@micromaxsa.com.au

Austria

EUCHNER G.m.b.H.
Süddruckgasse 4
2512 Tribuswinkel
Tel. +43-2252-421-91
Fax +43-2252-452-25
info@euchner.at

Benelux

EUCHNER (BENELUX) BV
Visschersbuurt 23
3350 AC Papendrecht
Tel. +31-78-6154-766
Fax +31-78-6154-311
info@euchner.nl

Brazil

EUCHNER Ltda
Av. Prof. Luiz Ignácio Anhaia Mello,
no. 4387
S. Lucas
São Paulo - SP - Brasil
CEP 03295-000
Tel. +55-11-2918-2200
Fax +55-11-2301-0613
euchner@euchner.com.br

Canada

IAC & Associates Inc.
2180 Fasan Drive
Unit A
Oldcastle, Ontario
NOR 1L0
Tel. +1-519-737-0311
Fax +1-519-737-0314
sales@iacnassociates.com

China

EUCHNER (Shanghai) Trading Co., Ltd.
No. 8 Workshop A, Hi-Tech Zone
503 Meinengda Road Songjiang
201613 Shanghai
Tel. +86-21-5774-7090
Fax +86-21-5774-7599
info@euchner.com.cn

Czech Republic

EUCHNER electric s.r.o.
Videňská 134/102
61900 Brno
Tel. +420-533-443-150
Fax +420-533-443-153
info@euchner.cz

Denmark

Duelco A/S
Mommarmvej 5
6400 Sønderborg
Tel. +45-7010-1007
Fax +45-7010-1008
info@duelco.dk

Finland

Sähkölehto Oy
Holkkitie 14
00880 Helsinki
Tel. +358-9-774-6420
Fax +358-9-759-1071
office@sahkolehto.fi

France

EUCHNER France S.A.R.L.
Parc d'Affaires des Bellevues
Allée Rosa Luxembourg
Bâtiment le Colorado
95610 ERAGNY sur OISE
Tel. +33-1-3909-9090
Fax +33-1-3909-9099
info@euchner.fr

Hong Kong

Imperial Engineers & Equipment Co. Ltd.
Unit B 12/F Cheung Lee Industrial Building
9 Cheung Lee Street Chai Wan
Hong Kong
Tel. +852-2889-0292
Fax +852-2889-1814
info@imperial-elec.com

Hungary

EUCHNER Ges.m.bH
Magyarországi Fióktelep
2045 Törökbálint
FSD Park 2.
Tel. +36-2342-8374
Fax +36-2342-8375
info@euchner.hu

India

EUCHNER (India) Pvt. Ltd.
West End River View
40, First Floor
Survey No. 169/1, Aundh
Pune 411007
Tel. +91-20-6401-6384
Fax +91-20-2588-5148
info@euchner.in
www.euchner.in

Teknic Euchner Pvt. Ltd.

64, Electronics City
Hosur Road
Bangalore 560100
Tel. +91-80-28520711
Fax +91-80-28520900
marketing@teknich-euchner.co.in

Israel

Ilan At Gavish Automation Service Ltd.
26 Shenkar St. Qiryat Arie 49513
P.O. Box 10118
Petach Tikva 49001
Tel. +972-3-922-1824
Fax +972-3-924-0761
mail@ilan-gavish.com

Italy

TRITECNICA S.r.l.
Viale Lazio 26
20135 Milano
Tel. +39-02-5419-41
Fax +39-02-5501-0474
info@tritecnica.it

Japan

Solton Co. Ltd.
2-13-7, Shin-Yokohama
Kohoku-ku, Yokohama
Japan 222-0033
Tel. +81-45-471-7711
Fax +81-45-471-7717
sales@solton.co.jp

Korea

EUCHNER Korea Co., Ltd.
RM 810 Daerung Technotown 3rd
#448 Gasang-Dong
Kumchon-Gu, Seoul
Tel. +82-2-2107-3500
Fax +82-2-2107-3999
info@euchner.co.kr

Mexico

SEPIA S.A. de C.V.
Maricopa # 10
302, Col. Napoles.
Del. Benito Juarez
03810 Mexico D.F.
Tel. +52-55-5536-7787
Fax +52-55-5682-2347
alazcano@sepia.mx

Poland

ELTRON
Pl. Wolności 7B
50-071 Wrocław
Tel. +48-71-3439-755
Fax +48-71-3460-225
eltron@eltron.pl

Republic of South Africa

RUBICON ELECTRICAL DISTRIBUTORS
4 Reith Street, Sidwell
6061 Port Elizabeth
Tel. +27-41-451-4359
Fax +27-41-451-1296
sales@rubiconelectrical.com

Romania

First Electric SRL
5, Luterana Street
App. 27, Sector 1
010161 Bucharest
Tel. +40-21-31231-39
Fax +40-21-31131-93
office@firstelectric.ro

Singapore

Sentronics Automation & Marketing Pte Ltd.
Blk 3, Ang Mo Kio Industrial Park 2A
#05-06
Singapore 568050
Tel. +65-6744-8018
Fax +65-6744-1929
sentronics@pacific.net.sg

Slovakia

EUCHNER electric s.r.o.
Spielberk Office Center
Holandská 8
639 00 Brno
Tel. +420-533-443-150
Fax +420-533-443-153
info@euchner.cz

Slovenia

SMM d.o.o.
Jaskova 18
2000 Maribor
Tel. +386-2450-2326
Fax +386-2462-5160
franc.kit@smm.si

Spain

EUCHNER, S.L.
Gurutzegi 12 - Local 1
Polígono Belartza
20018 San Sebastian
Tel. +34-943-316-760
Fax +34-943-316-405
comercial@euchner.es

Sweden

Censit AB
Box 331
33123 Värnamo
Tel. +46-370-6910-10
Fax +46-370-1888-8
info@censit.se

Switzerland

EUCHNER AG
Grofstrasse 17
8887 Mels
Tel. +41-81-720-4590
Fax +41-81-720-4599
info@euchner.ch

Taiwan

Daybreak Int'l (Taiwan) Corp.
3F, No. 124, Chung-Cheng Road
Shihlin 11145, Taipei
Tel. +886-2-8866-1234
Fax +886-2-8866-1239
day111@ms23.hinet.net

Turkey

Entek Otomasyon Urunleri San.ve Tic.Ltd.Sti.
Perpa Tic.Mer. B Blok
Kat: 11 No:1622 - 1623
34384 Okmeydani / Istanbul
Tel. +90-212-320-2000 / 01
Fax +90-212-320-1188
entekotomasyon@entek.com.tr

United Kingdom

EUCHNER (UK) Ltd.
Unit 2 Petre Drive,
Sheffield
South Yorkshire
S4 7PZ
Tel. +44-114-256-0123
Fax +44-114-242-5333
info@euchner.co.uk

USA

EUCHNER USA Inc.
6723 Lyons Street
East Syracuse, NY 13057
Tel. +1-315-7010-315
Fax +1-315-7010-319
info@euchner-usa.com

EUCHNER USA Inc.

Detroit Office
130 Hampton Circle
Rochester Hills, MI 48307
Tel. +1-248-537-1092
Fax +1-248-537-1095
info@euchner-usa.com

EUCHNER GmbH + Co. KG

Kohlhammerstraße 16

70771 Leinfelden-Echterdingen

Germany

Tel. +49-(0)711-7597-0

Fax +49-(0)711-753316

info@euchner.de

www.euchner.com

More than safety.



EUCHNER