

SIEMENS



Monitoring, Controlling and Switching with SIRIUS Relays

One range for every application

siemens.com/relays

Answers for industry.

The full-range SIRIUS relay portfolio

Every engineer knows that he must be completely up to date when it comes to controls, load feeders and drives. However, with coupling, control and monitoring relays, the search among the various suppliers becomes time-consuming. This is now a thing of the past because we have combined all these products in a single range: SIRIUS®. This makes it easy for you to select the optimum product and guarantees a top price-performance ratio.

SIRIUS relays – one range for every application

Our range of SIRIUS relays comprises everything required for motor feeder applications. With maximum ease and comfort. From a single source. Whether compact timing or reliable monitoring relays, particularly narrow coupling relays, plug-in relays, low-noise power relays or interface converters – our relay range is the most complete and comprehensive portfolio on the market. We offer relays for each and every application. Moreover, all SIRIUS relays offer outstanding ease of operation. Take a closer look at our portfolio and convince yourself. You will be surprised.

The highlights at a glance

- **Broad applicability**
comprehensive portfolio
- **User-friendly**
easy operation
- **Multi-functional**
flexibly applicable relays
- **Practice-oriented**
graded for customized performance
- **Open communication with the control**
thanks to IO-Link interface
- **Excellent cost/performance ratio**

Use of SIRIUS relays

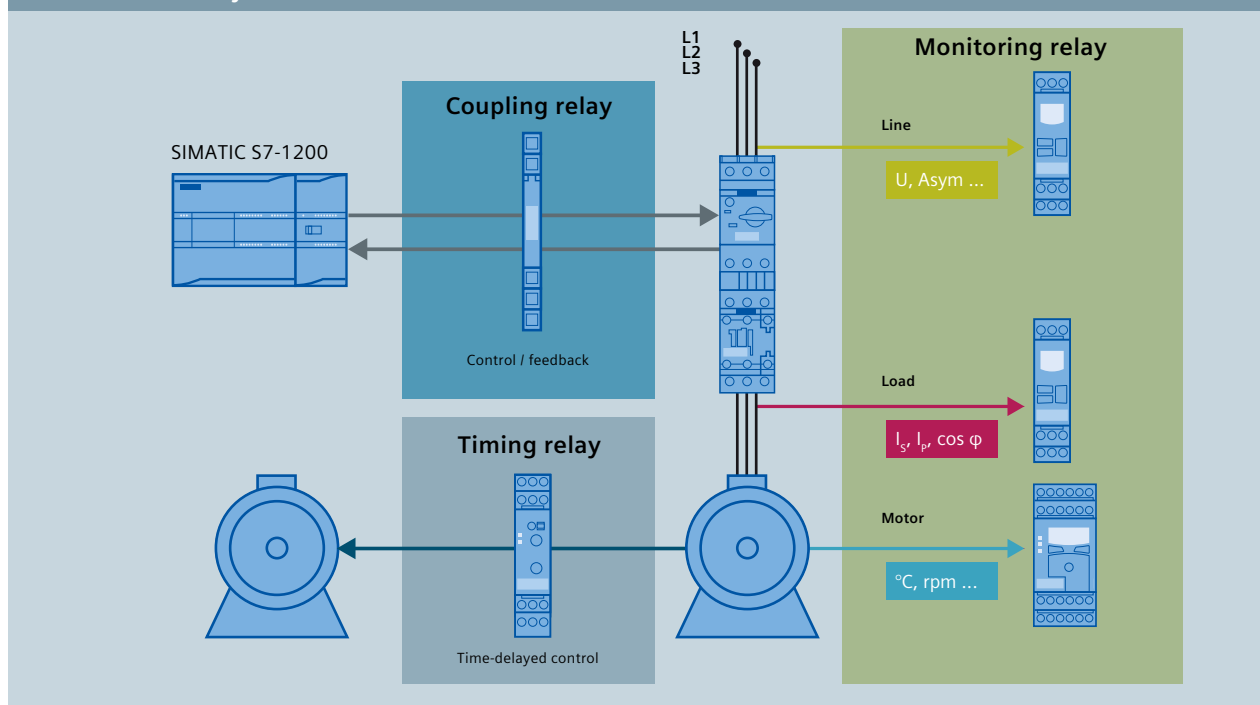

Contents

SIRIUS timing relays: Full control of all time sequences			
Timing relays	3RP15 / 20 and 7PV15 timing relays for DIN rail mounting	06 – 07 02 – 03*	
Function modules	3RA2811 / 12 / 16 function modules for mounting on 3RT2 contactors	08	04*
Time-delayed auxiliary switches	3RA2813 / 14 / 15 time-delayed auxiliary switches for mounting on 3RT2 contactors	*09	05*
SIRIUS monitoring relays: Perfect protection of machines and systems			
Monitoring relays	3UG451 / 461 / 463 monitoring relays for line and single-phase voltage monitoring – as 3UG481 / 483 also for IO-Link	10	06*
	3RR2 monitoring relays for direct mounting on contactors for multi-phase current monitoring – as 3RR24 also for IO-Link	12	07*
	3UG4621 / 4622 / 4641 monitoring relays for single-phase current monitoring, power factor and active current monitoring – as 3UG4822 / 4841 also for IO-Link	13	08*
	3UG4625 monitoring relays for residual current monitoring – as 3UG4825 also for IO-Link	14	09*
	3UG458 monitoring relays for insulation monitoring	15	09*
	3UG4501 monitoring relays for level monitoring	16	10*
	3UG4651 monitoring relays for speed monitoring – as 3UG4851 also for IO-Link	17	10*
Thermistor motor protection	3RN1 thermistor motor protection to protect against overheating	18	11*
Temperature monitoring relays	3RS10 / 3RS11 temperature monitoring relays (analog-adjustable)	20	12*
	Temperaturüberwachungsrelais 3RS10/11/20/21 (digital einstellbar) – als 3RS14/15 auch für IO-Link	21	13*
SIRIUS coupling relays: Perfect interaction of control and system			
Coupling relays	3TX700 / 701 coupling relays in narrow, compact design with relay output	22	14*
	3TX700 coupling relays in narrow, compact design with semiconductor output	23	15*
	3RS18 coupling relays in industrial enclosure	24	15*
	LZS / LZX coupling relays with plug-in relays	25	16*
Interface converters	3RS17 interface converters (standard signal and universal converters)	26	18*
Power relays	3TG10 power relays for high performance with minimum dimensions	28	19*

* Technical annex



SIRIUS Monitoring Relays for IO-Link

Reliable monitoring and protection

SIRIUS relays from Siemens offer maximum machine and system protection and now also communicate with the control level thanks to IO-Link. The new SIRIUS relays for IO-Link monitor line quality, current values, voltages, speeds and temperatures with the known reliability while supporting an even broader application area.

SIRIUS speaks IO-Link

With the SIRIUS monitoring relays for IO-Link, you opt for maximum flexibility: In addition to the unchanged autonomous monitoring function, measured values and data can be directly transferred to the control via IO-Link. Also parameterization can either be realized locally or via IO-Link. The SIRIUS relays for IO-Link are thus fully integrated in Totally Integrated Automation, our open system architecture for integrated automation. Moreover, you will benefit from considerably eased device replacement – thanks to data comparison and automatic re-parameterization via parameter servers.

Your advantages

- Precise monitoring of electrical, mechanical and temperature values
- Reliable protection of motors and system components
- Realization of simple autonomous temperature control tasks (2-point, 3-point control)
- Connection to the control level via IO-Link
- Central fault diagnostics and localization
- Eased commissioning and maintenance
- Efficient energy management with SIRIUS 3UG48: Support of the data formats defined in the PROFIenergy profile

SIRIUS monitoring relays for IO-Link:

- **SIRIUS 3RR24:** 3-phase current monitoring directly integrated in the load feeder
- **SIRIUS 3UG48:** Monitoring of electrical and mechanical parameters: Voltage, current, power factor and speed
- **SIRIUS 3RS14/15:** Monitoring of temperatures

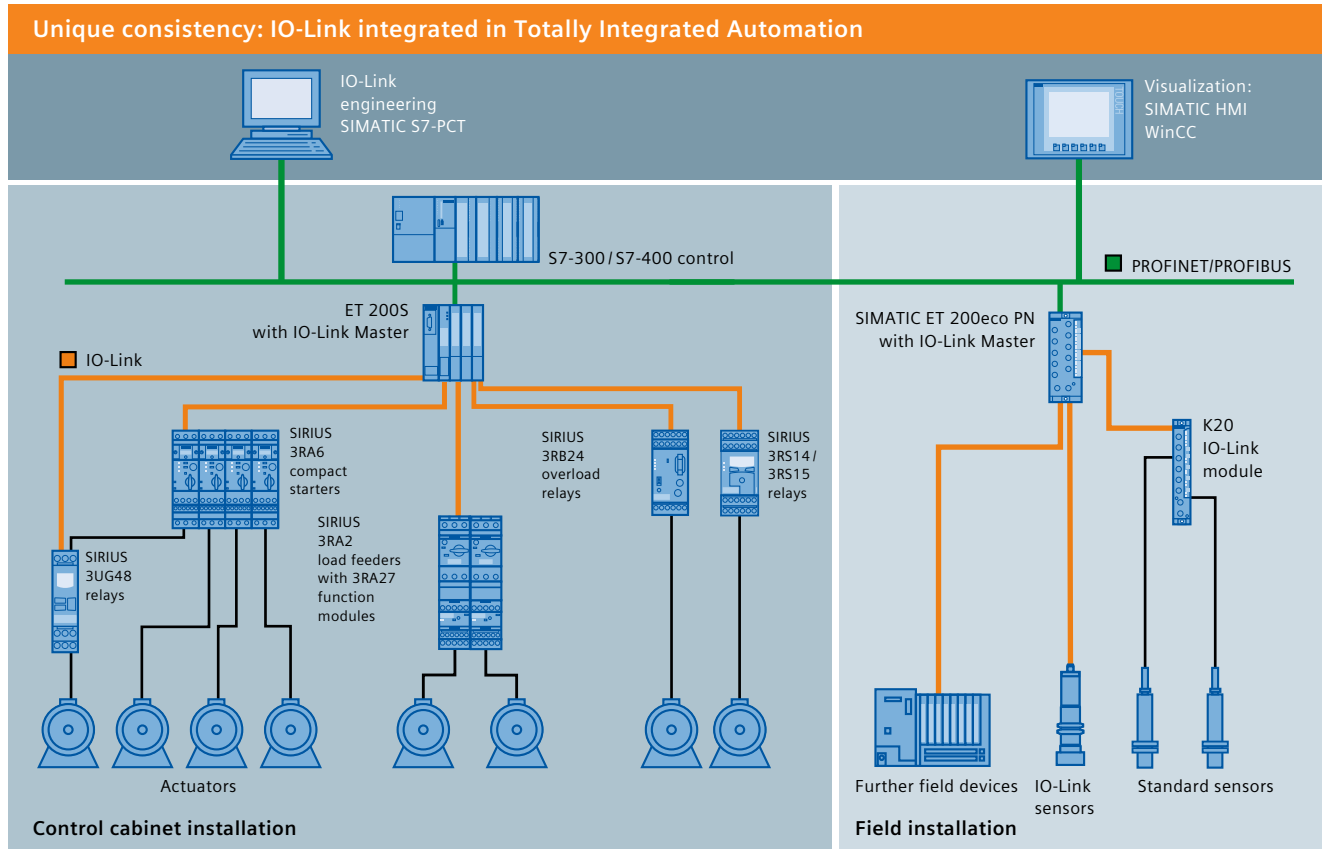



3RP15/20 and 7PV15 Timing Relays

for DIN rail mounting

Electronic timing relays are employed for all time-delayed switching processes in control, starting, protection and regulation circuits. Thanks to their elaborate operating concept and space-saving, compact design, the 3RP15 / 20 timing relays represent ideal timing devices for manufacturers of industrial control cabinets, power distribution boards and controls. With their narrow design, the 7PV15 timing relays are particularly suitable for applications in heaters, fans, air conditioning systems and compressors.



Application

ON-delay

- Interference pulse suppression (gating of interference pulses)
- Successive motor starting to prevent mains overloads, etc.

OFF-delay

- Generation of overtravel functions after disconnection of the control voltage (e.g. fan run-on)
- Successively delayed disconnection of motors, fans, etc., for targeted system shutdown

Wye(star)-delta

- Motor start-up with reduced starting current in wye (star) circuit
- Switchover to delta operation for full motor power after adjustable time
- Short switchover break to prevent inter-phase short-circuit with delayed contactor switching

Multifunction

- Maximum flexibility: One device with wide-range supply for all time functions

Your advantages

- Compact range for all applications thanks to multi-functional devices
- Significant logistical advantages thanks to versions with wide voltage and wide time setting ranges
- DIN rail mounting and disassembly without tools
- Cadmium-free relay contacts
- Recyclable, halogen-free enclosure

3RP15 / 20 timing relays

- Documentation of the function set on the multi-functional timing relay via label sets
- Sealable cover for safeguarding of set parameters

7PV15 timing relays

- Minimum variance: One design both for power distribution boards and control cabinets
- Compliance with EMC requirements for residential areas
- Switchover break with wye(star)-delta adjustable from 50 ms to 1 sec, for optimum adjustability to the application



**Application of the
3RP15 / 20 and 7PV15 ranges**

3RP15 – the premium range for all applications in industrial-standard width 22.5 mm: For variable use thanks to versions with 1 or 2 relays, screw or spring-type terminals, hard gold-plated contacts, positively driven operation, etc.

3RP20 – timing relays in contactor design: Recommended for small distance between DIN rails and/or low installation depths, e.g. in control boxes.

7PV15 – the version for standard applications: Narrow and cost-favorable, both for control cabinets and power distribution boards.

3RA2811 / 12 / 16 Function Modules

for mounting on 3RT2 contactors

The function modules facilitate the mounting of starters and contactor assemblies for direct-on-line and wye(star)-delta starting. They comprise all important control functions required for the respective feeder – e.g. timing and electric interlocking function. The function modules, which act as timing relays, can be rapidly and easily mounted on SIRIUS contactors – without laborious wiring. They support contactor switching both with ON- and OFF-delay.

Application

ON-delay

- Time-delayed starting of multiple drives for example reduces the summation starting current and thus prevents the occurrence of line voltage dips or cable overloads (cascade circuit)

OFF-delay

- Time-controlled disconnection of a drive's control signal after a start pulse, e.g. with gate control, follow-up ventilation

Function modules

for wye(star)-delta start

- Switchover during drive starting, e.g. switchover of large fans from wye (star) to delta as current-limiting measure
- Fixed switchover break of 50 ms for short-circuit protection
- Universal use thanks to wide voltage and large setting range of the wye (star) start time

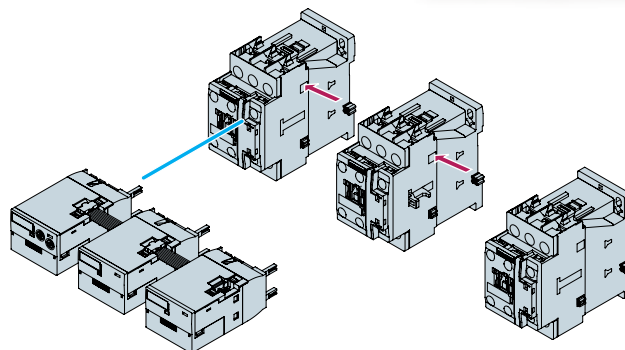

Wye(star)-delta function module:
Easy and fault-free mounting on 3RT2 contactors thanks to plug-in technology

Your advantages

- Reduction of control circuit wiring
- Prevention of wiring faults
- 24 – 240 V AC/DC wide voltage range for control supply voltage and contactor coil control
- Reduced testing costs
- Realization of control-independent timing functions
- Space savings in the control cabinet (compared to a separate timing relay)
- No additional protective circuit required (integrated varistor)
- Automatic preference circuit with wye(star)-delta function modules for further reduction of current peaks
- Assembly of wye(star)-delta starters, including timing function and electric interlocking, without additional wiring
- Approvals in accordance with IEC, CCC, UL and CSA standards

3RA2813 / 14 / 15 Time-Delayed Auxiliary Switches

for mounting on 3RT2 contactors

The electronically delayed auxiliary switches for mounting onto contactors are dimensioned for contactor coil voltages from 24 to 240 V AC/DC (wide voltage). Auxiliary switches for control and status signals are employed especially for the switching of very small signals for electronic applications. They are used for example for pump or fan run-on similar to OFF-delay timing relays or the delayed switch-on of a gate drive. Both the electrical and mechanical connection are realized by simply snapping the device on and locking it. A varistor is integrated in the time-delayed auxiliary switch for the attenuation of switching overvoltages in the contactor coil.



Application

ON-delay

- For example for the delayed readiness signaling of a drive after start-up with centrifugal mass

OFF-delay

- Generation of run-on functions for fans or pumps after disconnection of the control voltage

Your advantages

- Flexible use for all contactor control supply voltages in the 24–240 V AC/DC range
- Selectable outputs 1 NO + 1 NC or 1 CO
- All modules with 24–240 V AC/DC wide voltage in the auxiliary circuit
- Integrated electric interlocking and factory-integrated varistor (protective circuit) - easy configuration
- Plug-on function modules for connection without tools
- High setting accuracy thanks to selectable time ranges
- Reduced variance – only 1 module for sizes S00 and S0
- Add-on modules for reduced wiring and space savings

Differences SIRIUS 3RA2811 / 12 / 16 and 3RA2813 / 14 / 15

- Unlike DIN rail mounted timing relays, 3RA2811 / 12 / 16 function modules do not feature any relay outputs. They represent timing relays which are directly mounted on 3RT2 contactors. Instead of the contactors, the function modules are controlled which then switch the contactors below via direct contact with the contactor coil.
- With 3RA2813/14/15 time-delayed auxiliary switches, the 3RT2 contactor is controlled which then switches on or off instantaneously. The auxiliary switch mounted on the contactor responds to this via voltage tap on the contactor coil and switches the relay outputs with a time delay.



3UG451 / 461 / 463 and 3UG481 / 483 Monitoring Relays

for line and voltage monitoring

The 3UG4 monitoring relays provide a maximum degree of protection for machines and systems. They facilitate the early detection of line and voltage faults, allowing for their rectification before any consequential damage can occur.

IO-Link



Scan the QR code and watch a video!

Application

Typical applications can be derived from the table on page 11.

Your advantages

- Can be used in all global networks from 160 to 600 V AC without separate auxiliary voltage thanks to wide voltage range
- Variably adjustable to overshoot, undershoot or window monitoring
- Freely parameterizable delay times and RESET response
- Narrow width for all versions
- Permanent display of ACTUAL value and type of line fault with digital versions
- Automatic direction of rotation correction thanks to differentiation between power system fault and incorrect phase sequence

Configuration of 3-phase line monitoring

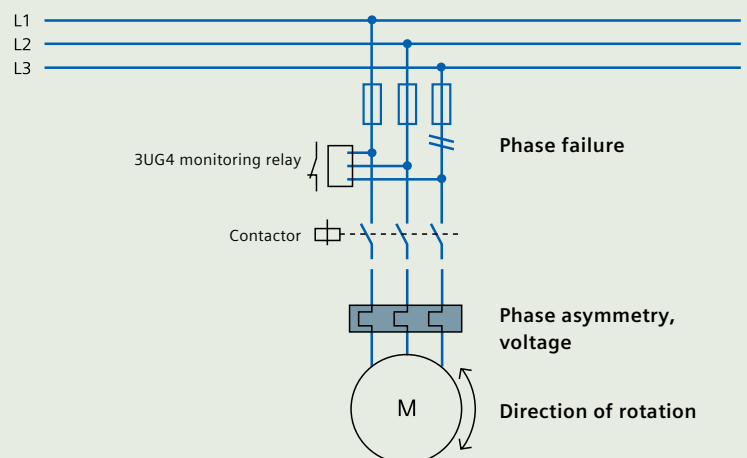



Measured variable	Possible system fault
Phase sequence	<ul style="list-style-type: none"> • Direction of rotation of the drive
Phase failure	<ul style="list-style-type: none"> • Fuse tripping • Control supply voltage failure • Single-phase operation of a motor with corresponding overheating
Phase asymmetry	<ul style="list-style-type: none"> • Motor overheating due to asymmetric voltages or phase failure • Detection of asymmetrically loaded supply systems • Phase failure detection despite regenerative feedback
Undervoltage	<ul style="list-style-type: none"> • Increased motor current with respective overheating • Unintended device reset • Mains failure, particularly with battery supply • Threshold value switch for analog signals from 0 to 10 V
Overvoltage	<ul style="list-style-type: none"> • System protection against destruction caused by supply overvoltages • System switch-on upon reaching a certain voltage • Threshold value switch for analog signals 0 to 10 V

3RR2 Monitoring Relays

for direct mounting on contactors for multi-phase current monitoring

The 3RR2 monitoring relays are used not only for monitoring motors or other loads, but additionally also facilitate optimum current monitoring of the entire system or driven process. This for example allows for the early detection and signaling of load shedding or motor overloads. The 3RR2 monitoring relay for current monitoring is directly integrated in the load feeder. It is simply plugged onto the contactor.



Scan the QR code and watch a video!

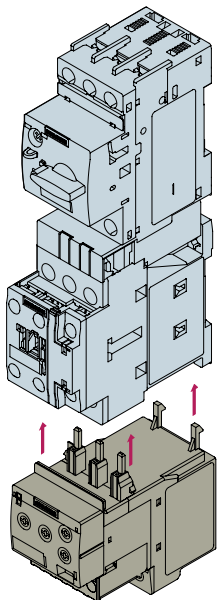

Current monitoring directly in the main circuit

Application

- Monitoring for current overshoot and undershoot
- Monitoring of open circuit
- Monitoring of no-load operation and load shedding, e.g. in the event of a torn V-belt or no-load operation of a pump
- Monitoring of overload, e.g. caused by excessive loading of conveyor belts or cranes
- Monitoring of the functionality of electric loads such as heaters
- Monitoring of wrong phase sequences on mobile equipment such as compressors or cranes
- Monitoring of high-impedance faults to ground, e.g. due to damaged insulation or moisture

Your advantages

- Direct mounting on 3RT2 contactors, i.e. no additional wiring overhead in the main circuit
- Optimally matched to the technical characteristics of 3RT2 contactors, no separate current transformers required
- 2- or 3-phase current monitoring, apparent or active current monitoring
- Display of ACTUAL values and status messages
- Easy determination of threshold values by means of direct reference to actually measured values under setpoint load
- Only one device is required for motor monitoring along the entire torque curve
- Monitoring for cable breakage, phase failure, phase sequence, residual current as well as motor blocking

3UG4621 / 4622 / 4641 and 3UG4822 / 4841 Monitoring Relays

for single-phase current, power factor and active current monitoring

The 3UG4 relays for current, active power and active current monitoring are ideally suited for monitoring the load of motors and the functionality of electronic loads. These devices detect signs of wear and faults early on, thereby for example facilitating the timely implementation of maintenance measures to prevent system failures.



Application

Current monitoring

- Overload monitoring
- Underload monitoring close to the rated torque
- Monitoring of the functionality of electric loads
- Wire breakage monitoring
- Energy management (phase current monitoring)
- Threshold value switch for analog signals from 4 to 20 mA

Power factor and active current monitoring

- No-load monitoring
- Underload monitoring in the lower power range
- Overload monitoring
- Easy power factor monitoring in networks for the control of compensation systems
- Energy management
- Cable breakage between control cabinet and motor



Scan the QR code and watch a video!

Current and active power depending on the motor load

Rule of thumb: The power factor changes significantly below the rated load; the current increases disproportionately above the rated load.

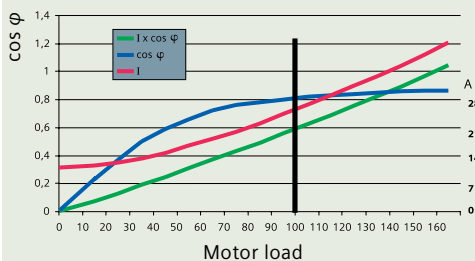

The active current I_{res} indicates a linear correlation between the motor load and the measured value over the entire measuring range.

Your advantages

- Reduced stock-keeping thanks to wide-voltage versions
- Variably adjustable to overshoot, undershoot or window monitoring
- Freely parameterizable delay times and RESET response
- Permanent display of ACTUAL value and type of fault
- Setting of monitoring limits on the basis of real measured values
- Real rms value measurement

Current monitoring

- Only two versions from 2 mA to 10 A
- Applicable for frequencies with 40–500 Hz AC and DC

Power factor and active current monitoring

- Global use thanks to wide voltage from 90 to 690 V AC
- Monitoring of smaller single-phase motors with a no-load current below 0.5 A
- One device for motor monitoring, from no-load to overload
- Voltage-independent monitoring of the motor load

3UG4625 and 3UG4825 Monitoring Relays

for residual current monitoring

Residual-current monitoring relays are used for monitoring residual currents that can result in insulation problems in plants due to humidity or severe contamination. By using the 3UG4625 or 3UG4825 residual-current monitoring relay in combination with a 3UL23 summation current transformer, such hazards can be eliminated. Thanks to adjustable limit or warning threshold values, the relay issues a warning before the limit value is reached and switches off reliably when the limit value is exceeded after a certain delay time.

The 3UG4825 monitoring relays have an IO-Link interface for digital transfer of measured values to the control.

IO-Link



Application

Monitoring of systems prone to residual currents, e.g. caused by:

- Dust deposits or humidity
- Porous cables and lines
- Capacitive residual currents

Ihre Vorteile

- Can be used worldwide thanks to a wide voltage range from 24 to 240 V AC/DC
- Measuring range from 30 mA to 40 A
- Variably adjustable threshold values for warning and disconnection
- Freely parameterizable delay times and RESET response and connectable fault memory
- Permanent display of the actual value and fault diagnostics via display
- High level of flexibility and space saving through installation of the transformer outside the control cabinet
- All diagnostics data are now available in the control

3UG458 Monitoring Relays

for insulation monitoring

Insulation monitoring relays are used for monitoring the insulation resistance between ungrounded single or three-phase current supplies and a protective conductor. Ungrounded, i.e. isolated networks (IT networks) are always used where high demands are placed on the reliability of the power supply, e.g. emergency lighting systems. After an initial insulation fault it is possible to continue working in safety (single-fault safety). The fault must still be rectified as quickly as possible before a second insulation fault occurs (e.g. according to DIN VDE 0100-410). For this purpose insulation monitoring relays are used which constantly measure the resistance to ground of the phase conductor and the neutral conductor, reporting a fault immediately if insulation resistance falls below the set value.



Application

Amongst others, IT networks are employed in the following applications:

- Emergency power supply systems
- Emergency lighting systems
- Industrial production plants with high availability requirements (chemical industry, automotive industry, printing industry)
- Marine and railway applications
- Mobile current generators (airplanes)
- Renewable energies, e.g. wind energy and photovoltaic plants
- Mining

Your advantages

- Devices for AC and DC systems
- All devices with wide supply voltage range
- Direct connection to networks with line voltages up to 690 V AC and 1000 V DC via voltage reducer module
- With AC networks: Frequency range 15 ... 400 Hz
- Monitoring for line breakage
- Monitoring for faulty settings
- Application safety thanks to integrated system start after start-up
- Reset and test option (via button on the front or control contact)
- Rapid response times thanks to new predictive measuring principle

3UG4501 Monitoring Relays

for level monitoring

3UG4 monitoring relays also detect non-electrical variables. Our 3UG4501 level monitoring relays thus ensure reliable 1- and 2-point controls and alarms in case of overflow or dry running – according to a simple principle: almost all liquids are conductive. This is utilized for monitoring levels. If the probes are immersed in the liquid, current flows – if the probes fall dry, no current flows.



Scan the QR code and watch a video!



Application

- 1- and 2-point level control
- Overflow protection
- Dry running protection
- Leakage monitoring

Your advantages

- Can be used worldwide thanks to wide voltage range from 24 to 240 V AC/DC
- Individually trimmable 2- and 3-pole wire electrodes for easy mounting from the top/bottom
- Bow electrodes for lateral installation for higher filling levels and minimum space requirements
- Flexibly adjustable to various conductive liquids through analog setting of the sensitivity from 2 to 200 k Ω
- Compensation of wave movements thanks to tripping delay times from 0.1 to 10 seconds
- Selectable feed or discharge function

1- and 2-point level monitoring, overflow protection

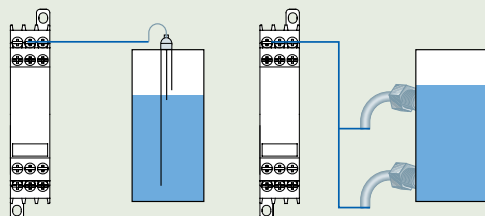

This method is applicable with very many liquids and substances.
Prerequisite:
Specific resistance < 200 k Ω

Product k Ω		Product k Ω	
Buttermilk	1	Natural water	5
Fruit juice	1	Waste-water	5
Vegetable juice	1	Starch solution	5
Milk	1	Oil	10
Soup	2.2	Condensed water	18
Beer	2.2	Soap foam	18
Coffee	2.2	Jams	45
Ink	2.2	Jellies	45
Salt water	2.2	Sugar solution	90
Wine	2.2	Whisky	220
		Distilled water	450

3UG4651 and 3UG4851 Monitoring Relays

for speed monitoring

The 3UG4651 and 3UG4851 speed monitoring relays monitor the setpoint speed of motors, shafts or driven wheels for overshoot or undershoot. Implementing a period measurement, they monitor the pulses delivered per rotation from the sensors. In addition, the relays are suitable for all functions requiring the monitoring of a continuous pulse signal, e.g. belt operation and scan time monitoring or bypass control. The 3UG4851 monitoring relays have an IO-Link interface for digital transfer of measured values to the control.



Scan the QR code and watch a video!

Application

- Slip/breakage of a belt drive
- Load shedding
- Standstill monitoring (no operator protection)
- Transport item monitoring for completeness

Your benefits

- Can be used worldwide thanks to wide voltage range from 24 to 240 V AC
- Variably adjustable to overshoot, undershoot or window monitoring
- Freely parameterizable delay times and RESET response
- Permanent display of ACTUAL values or type of fault
- Use of up to 10 sensors per rotation with extremely slowly rotating motors
- Connection option for 2- or 3-conductor sensors and sensors with mechanical switching or electronic output
- Integrated auxiliary voltage for sensor

Speed monitoring example with 3UG4651

Without enable input

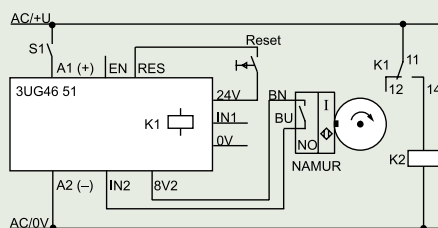

With enable input

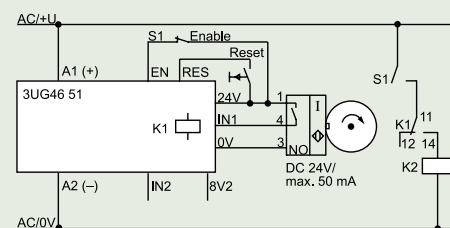

3RN1 Thermistor Motor Protection

for protection against overheating

Thermistor motor protection relays provide decisive benefits in cases in which current-dependent protection using either a circuit breaker or an overload relay is not the perfect solution: In specific cases, often as a result of external effects, overheating can occur without being detected by the thermal image in the circuit breaker or overload relay. Examples for this include heavy-duty starting (e.g. centrifuges), operation with frequency converters or frequent switching, braking operations or when cooling is restricted, e.g. due to accumulated dirt.



Application

- Protection of motors against overheating, particularly with heavy-duty starting, braking operation, frequent switching or insufficient cooling
- "Warning and disconnection" function based on two sensor circuits with different response temperatures for responding prior to disconnection (additional cooling, load reduction, etc.)
- Multiple motor protection with only one device, e.g. with conveyor lines comprising multiple motors which are to be disconnected jointly

Characteristics for type A thermistor sensor

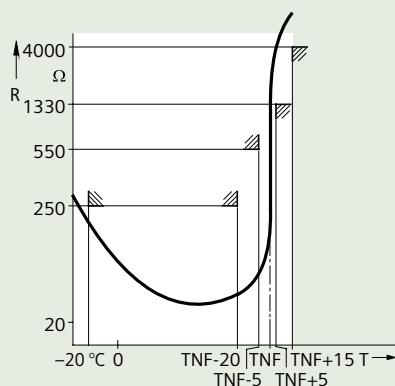

Your advantages

- Direct measuring of the motor winding temperature
- Only one device for all motor power ratings
- Device/terminal labeling acc. to DIN EN 50005 for "normal" switching relays and for overload protection systems
- Relays with hard gold-plated contacts for application under difficult conditions
- Indication of wire breakage and short circuit in the sensor circuit via LED
- Version with safe isolation up to 300 V in accordance with DIN/VDE 0106 as well as version with bistable relays for special cases
- ATEX approval for gases and dust



3RS10 / 3RS11 Temperature Monitoring Relays

analog-adjustable

The 3RS10 / 3RS11 temperature monitoring relays are specialized in the measuring of temperatures in solid, liquid and gaseous media. The temperature is detected via sensors inside the medium, then evaluated by the device and monitored for overshoot or undershoot of the limit temperatures. Depending on the parameterization, the output relay switches on or off upon reaching the threshold values.



Application

- Motor and system protection
- Control cabinet temperature monitoring
- Frost monitoring
- Temperature limits for process parameters, e.g. in the packing industry or galvanizing systems
- System and machine control, e.g. heating, air conditioning and ventilation systems, solar collectors, heat pumps or hot water supply systems
- Bearing and gear oil monitoring
- Coolant monitoring



Your advantages

- All devices with galvanic isolation, exception: 24 V AC/DC
- Easy operation via rotary potentiometer
- Selectable hysteresis
- Selectable operating principle for devices with two threshold values

3RS10 / 11 / 20 / 21 and 3RS14 / 15 Temperature Monitoring Relays

digital-adjustable

Suitable for temperature measuring in solid, liquid and gaseous media, these relays monitor temperatures for overshoot and undershoot or within a specific operating range (window function). The devices also present a good alternative to temperature controllers in the low-end range.



Application

- System and environmental protection
- Temperature limits for process parameters, e.g. in the packing industry or galvanizing systems
- Temperature monitoring for heat generation plants
- Monitoring of exhaust gas temperatures
- System and machine control, e.g. heating, air conditioning and ventilation systems, solar collectors, heat pumps or hot water supply systems
- Motor, bearing and gear oil temperature monitoring
- Coolant monitoring

Your advantages

- Easy operation without complicated menu guidance
- 3-digit LED display for indication of the temperature
- Connection option for resistance sensors in 2- or 3-conductor technology
- Galvanic isolation with wide voltage supply versions
- Availability of versions in °C and °F (switchover from °C to °F possible with IO-Link versions)



Scan the QR code and watch a video!

Characteristics of most important resistance temperature sensors

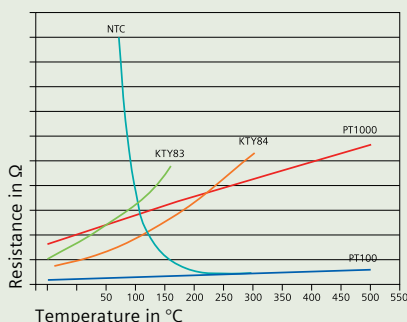

Characteristics for thermocouples

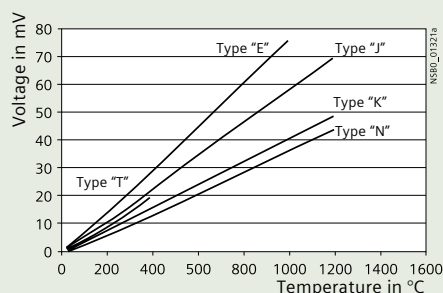

Characteristics for sensor types J, K, T, E and N

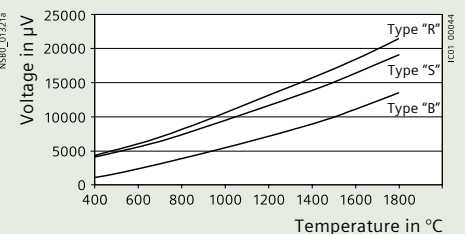

Characteristics for sensor types S, R, and B

3TX700 / 701 Coupling Relays

in narrow, compact design with relay output

The 3TX70 coupling relays are available in two designs for space-optimized application in the control cabinet. On the one hand, the coupling relays with a width of only 6.2 mm require only minimum space on the DIN rail. On the other hand, a range of coupling relays with minimum depth / height is available for assembly in the control cabinet with minimum line spacing or in flat control boxes.



Application

- Galvanic isolation
- Voltage conversion, e.g. from 24 V DC to 230 V AC
- Signal amplification
- Contact multiplication
- General relay controls
- Overvoltage and EMC protection of controls

Your advantages with 3TX7002 / 03 (compact enclosure) and 3TX7004 / 05 (6.2 mm width)

- Soldered relays (not pluggable) for increased contact reliability
- Operating range from 0.7 to 1.25 U_s
- Temperature range up to 60 °C with 24 V DC
- Protective circuit integrated in the input
- Connection comb and cable for bridging of identical potentials
- Simpler commissioning thanks to manual-0-automatic switch

Your advantages with 3TX7014 and 3TX7015 (6.2 mm width)

- Plug-in relays for rapid replacement with permanent wiring
- Reduced wiring time thanks to wire entry and clamping via the front
- Reduced mounting time thanks to tested complete devices
- Availability of individual relays as spare parts
- Device version with hard gold-plated contacts for high contact reliability

Coupling relays as input or output coupler

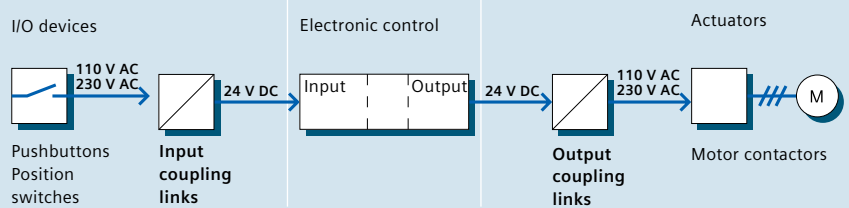

3TX700 Coupling Relays

in narrow, compact design with semiconductor output

Coupling modules are available with conventional relays or with semiconductor outputs. Compared to relays, the coupling modules with semiconductor output offer significant advantages: The electronic components are extremely reliable and have a very long service life (see diagram). The input coupler combines both advanced technology and price advantages. With regard to output couplers, the decision as to whether to opt for „relay or semiconductor“ should be based on the requirements regarding switching capacity and switching cycles. If a relay has to be replaced just once during the entire service life of a machine, then a semiconductor coupler has already paid off.



Application

- Galvanic isolation, voltage conversion
- Switching of DC loads
- Switching of capacitive loads
- Overvoltage and EMC protection of controls

Your advantages with 3TX700 with semiconductor output

- Very long electrical service life
- Maximum contact reliability
- High DC switching capacity
- Short switching times
- Easy bridging of identical potentials thanks to suitable accessories
- High number of switching cycles
- Noise-free switching

Use of semiconductor couplers

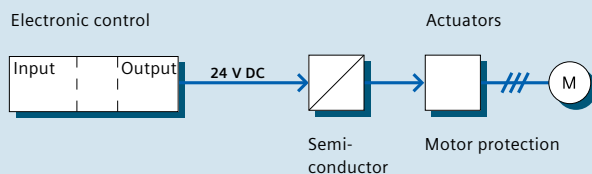

Service life comparison

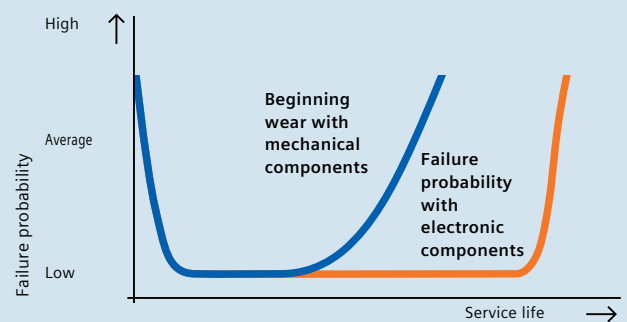

Electronic coupling modules have a significantly longer service life than electromechanical ones.

3RS18 Coupling Relays

in industrial enclosure

The 3RS18 relay coupling set standards: With a wide voltage range extending from 24 V bis 240 V AC/DC they are an absolute highlight in the coupling market. We offer you in this range devices in the field-proven 22.5 mm industrial enclosure with one, two or three changeover contacts – with screw-type or spring-type terminals and in combined voltage or wide voltage with hard-gold-plated contacts for particularly high contact reliability even with low currents. thanks to the field-proven industrial enclosure you benefit - as with our timing relays - from a user-friendly connection method with permanent wiring. Two conductors per clamping point can be connected.



Application

- Wherever electronically optimized contacts are required and devices with wide voltage are used
- Predestined for inputs and outputs on PLC thanks to hard gold-plated contacts

Your advantages

- One product for all voltages
- Cost savings thanks to reduced variance
- Particularly high contact reliability even with low currents

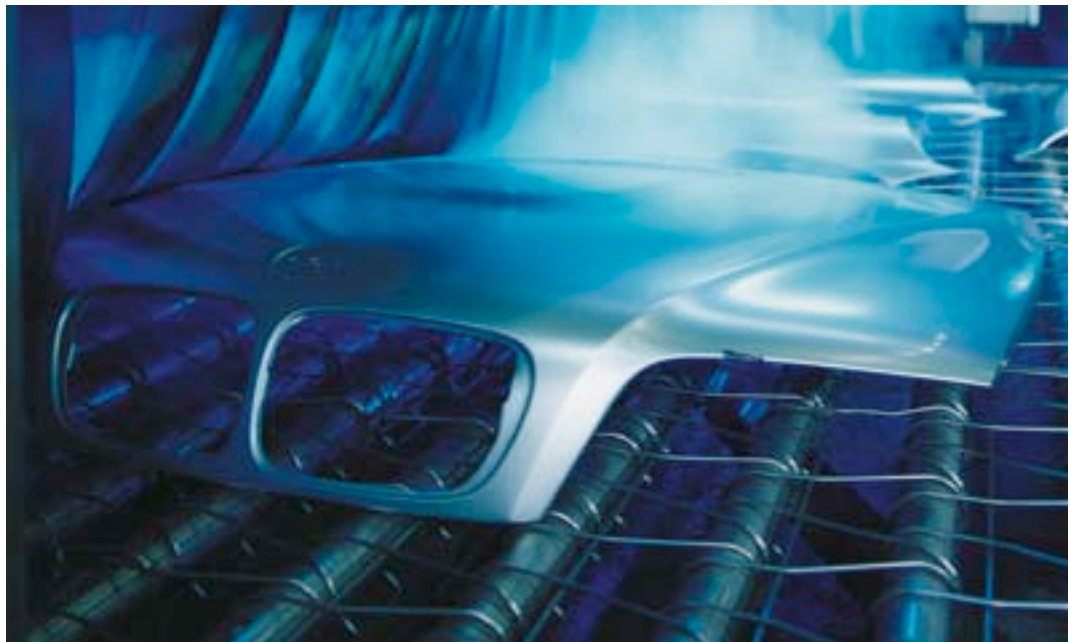

LZS Coupling Relays

with plug-in relays

Plug-in relay couplers are available both as complete devices and as individual modules for self-assembly or spare parts requirements. The range is divided into three types: RT, PT and MT.



Application

- As coupling relay for galvanic isolation between field and input and outputs of electronic controls
- Contact multiplication
- Switching of small loads
- As potential transfer switch

Your advantages

- Wiring without tools and vibration-proof connection thanks to innovative push-in spring-type terminals
- Base with logical isolation for easy wiring
- Tested AC-15 and DC-13 switching capacity
- Available coil voltages: 24 V DC, 24 V AC, 115 V AC, 230 V AC
- Hard gold-plated contacts for optimum interaction with electronic controls

- ① Wiring bracket for push-in spring-type terminal base and
- ② Screw terminal base



Configuration information

The test lever of the PT relay does not feature a latching mechanism. If the test lever is pressed further until a movement of 90° is reached, two small snap-in lugs break off and the test lever can be set to latching. When using plug-in relays with voltages of 60 Hz AC, the lower response value has to be increased by 10 %, the power loss decreases slightly.

Types

LZS:RT

1 or 2 CO contacts
AC-1: 16/8 A
Width: 15.5 mm



LZS:PT

2, 3 or 4 CO contacts
AC-1: 12/10/6 A
Width: 28 mm



LZS:MT

3 CO contacts
AC-1: 10 A
Width: 38 mm



3RS17 Interface Converters

Standard signal and universal converters

Interface converters are mainly used for the galvanic isolation and conversion of analog signals. Sensors / actuators and controls generally have different power supply units and therefore require galvanic isolation in the signal circuit. This is either realized in the control or via an interface converter.

Signal conversion is for example required when a voltage signal has to be transferred as a current signal over a long distance or when the output of a sensor and the input of a control are incompatible.

A further application is supported by the realized frequency outputs. Here, the input signal is converted into a proportional frequency. As a result, analog signals can be processed with digital inputs. This is important in cases where the control does not feature a slot for an analog input or when all slots are already assigned, e.g. with retrofits.



Application

- Galvanic isolation of analog signals
- Conversion of analog signals
- Conversion of analog signals into a frequency
- Conversion of non-standardized signals into standardized signals
- Overvoltage protection of analog inputs

Your advantages

- Minimum width
- Easily adjustable universal converters
- Converters with frequency output
- Full calibration of all areas
- Integrated range, the ideal solution for every application
- Integrated manual-automatic switch with setpoint generator
- Short-circuit-proof outputs
- Protection against damage caused by faulty wiring up to 30 V

Passive converters

Passive converters do not require any supply voltage as their required energy is supplied via the analog signal.

2-way isolation

With 2-way isolation, the input is electrically isolated from the output. The "zero potential" of the supply voltage is the same as the reference potential for the analog output signal.

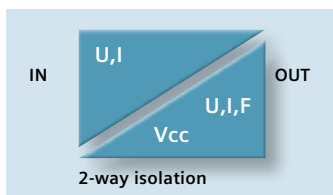

3-way isolation

For 3-way isolation, each circuit is electrically separated from the other circuits, i.e. input, output, and supply voltage do not have equipotential bonding.

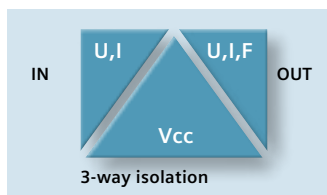



3TG10 Power Relays

for high performance with minimum dimensions

The 3TG10 power relays are the ideal solution for all applications requiring small, low-noise relays or contactors at low costs. The power relays are suitable for basic controls and particularly for use in large-scale series devices and controls. They are ideal for applications which require only one auxiliary contact and no overload relay – and place increased requirements upon switching capacity, switching voltage and service life.



Application

- Domestic appliances and installations
- Hoisting systems: Small elevators, elevating platforms
- Building technology, hum-free application in building systems, e.g. in hospitals

Your advantages

- Any mounting position, hum-free
- Safe isolation
- Screw-type or plug-in connection
- Integrated auxiliary switch
- AC-3 power: 4 kW / 400 V
- Operating current I_e /AC-1: 20 A/400 V
- Inrush current per phase: 90 A
- Integrated overvoltage damping
- Narrow width of only 36 mm

Configuration information

With a 20 A load on the three main current paths, the following applies with $I > 10$ A for the fourth current path:
Permissible ambient temperature 40 °C



Scan the
QR code
for further
information



Further information:
siemens.com/relays

Siemens AG
Industry Sector
Control Components
and System Engineering
P.O. Box 48 48
90026 NUREMBERG
GERMANY

Subject to change 03/13
Order No. E20001-A1800-P302-V1-7600
Dispo 27601
21/42527 MI.CE.SG.REXX.52.2.01 WS 03131.
Gedruckt in Deutschland
© Siemens AG 2013

The information provided in this brochure contains merely general descriptions or characteristics of performance which in actual case of use do not always apply as described or which may change as a result of further development of the products. An obligation to provide the respective characteristics shall only exist if expressly agreed in the terms of contract.

All product designations may be trademarks and product names of Siemens AG or supplier companies whose use by third parties for their own purposes could violate the rights of the owners.

SIEMENS



Technical
Data

Monitoring, Controlling and Switching with SIRIUS Relays

[siemens.com/relays](https://www.siemens.com/relays)

Answers for industry.

SIRIUS 3RP15/3RP20 Timing Relays

3RP15 electronic timing relays in industrial enclosure 22.5 mm

Function	Contacts	Time range	Rated control supply voltage U_s	Order No.
8 functions	1 CO	0.05 s – 100 h	DC 12 V	3RP1505-1AA40
8 functions	1 CO	0.05 s – 100 h	AC/DC 24/AC 100 – 127 V	3RP1505-□AQ30
8 functions	1 CO	0.05 s – 100 h	AC/DC 24/AC 200 – 240 V	3RP1505-□AP30
8 functions	1 CO	0.05 s – 100 h	AC/DC 24 – 240 V	3RP1505-□AW30
8 functions	2 CO	0.05 s – 100 h	AC/DC 24 – 240 V	3RP1505-□RW30 ¹⁾
16 functions	2 CO	0.05 s – 100 h	AC/DC 24/AC 100 – 127 V	3RP1505-□BQ30
16 functions	2 CO	0.05 s – 100 h	AC/DC 24/AC 200 – 240 V	3RP1505-□BP30
16 functions	2 CO	0.05 s – 100 h	AC/DC 24 – 240 V	3RP1505-□BW30
16 functions	2 CO	0.05 s – 100 h	AC 400 – 440 V	3RP1505-1BT20
ON-delay	1 CO	0.5 s – 10 s	AC/DC 24/AC 100 – 127 V	3RP1511-□AQ30
ON-delay	1 CO	0.5 s – 10 s	AC/DC 24/AC 200 – 240 V	3RP1511-□AP30
ON-delay	1 CO	1.5 s – 30 s	AC/DC 24/AC 100 – 127 V	3RP1512-□AQ30
ON-delay	1 CO	1.5 s – 30 s	AC/DC 24/AC 200 – 240 V	3RP1512-□AP30
ON-delay	1 CO	5 s – 100 s	AC/DC 24/AC 100 – 127 V	3RP1513-□AQ30
ON-delay	1 CO	5 s – 100 s	AC/DC 24/AC 200 – 240 V	3RP1513-□AP30
ON-delay	1 CO	0.05 s – 100 h	AC/DC 24/AC 100 – 127 V	3RP1525-□AQ30
ON-delay	1 CO	0.05 s – 100 h	AC/DC 24/AC 200 – 240 V	3RP1525-□AP30
ON-delay	2 CO	0.05 s – 100 h	AC/DC 42 – 48/60 V	3RP1525-1BR30
ON-delay	2 CO	0.05 s – 100 h	AC/DC 24/AC 100 – 127 V	3RP1525-□BQ30
ON-delay	2 CO	0.05 s – 100 h	AC/DC 24/AC 200 – 240 V	3RP1525-□BP30
ON-delay	2 CO	0.05 s – 100 h	AC/DC 24 – 240 V	3RP1525-□BW30
ON-delay, 2-wire	1 NO, Q	0.05 s – 240 s	AC/DC 24 – 66 V	3RP1527-□EC30
ON-delay, 2-wire	1 NO, Q	0.05 s – 240 s	AC/DC 90 – 240 V	3RP1527-□EM30
OFF-delay with auxiliary voltage	1 CO	0.5 s – 10 s	AC/DC 24/AC 100 – 127 V	3RP1531-□AQ30
OFF-delay with auxiliary voltage	1 CO	0.5 s – 10 s	AC/DC 24/AC 200 – 240	3RP1531-□AP30
OFF-delay with auxiliary voltage	1 CO	1.5 s – 30 s	AC/DC 24/AC 100 – 127 V	3RP1532-□AQ30
OFF-delay with auxiliary voltage	1 CO	1.5 s – 30 s	AC/DC 24/AC 200 – 240 V	3RP1532-□AP30
OFF-delay with auxiliary voltage	1 CO	5 s – 100 s	AC/DC 24/AC 100 – 127 V	3RP1533-□AQ30
OFF-delay with auxiliary voltage	1 CO	5 s – 100 s	AC/DC 24/AC 200 – 240 V	3RP1533-□AP30
OFF-delay without auxiliary voltage	1 CO	0.05 s – 600 s	AC/DC 24 V	3RP1540-□AB31
OFF-delay without auxiliary voltage	1 CO	0.05 s – 600 s	AC/DC 100 – 127 V	3RP1540-□AJ31
OFF-delay without auxiliary voltage	1 CO	0.05 s – 600 s	AC/DC 200 – 240 V	3RP1540-□AN31
OFF-delay without auxiliary voltage	1 CO	0.05 s – 600 s	AC/DC 24 – 240 V	3RP1540-□AW31
OFF-delay without auxiliary voltage	2 CO	0.05 s – 600 s	AC/DC 24 V	3RP1540-□BB31
OFF-delay without auxiliary voltage	2 CO	0.05 s – 600 s	AC/DC 100 – 127 V	3RP1540-□BJ31
OFF-delay without auxiliary voltage	2 CO	0.05 s – 600 s	AC/DC 200 – 240 V	3RP1540-□BN31
OFF-delay without auxiliary voltage	2 CO	0.05 s – 600 s	AC/DC 24 – 240 V	3RP1540-□BW31
Clock generator	1 CO	0.05 s – 100 h	AC/DC 42 – 48/60 V	3RP1555-□AR30
Clock generator	1 CO	0.05 s – 100 h	AC/DC 24/AC 100 – 127 V	3RP1555-□AQ30
Clock generator	1 CO	0.05 s – 100 h	AC/DC 24/AC 200 – 240 V	3RP1555-□AP30
Wye-delta with overtravel function	3 x 1 NO	1 s – 20 s, 30 s – 600 s (overtravel)	AC/DC 24/AC 100 – 127 V	3RP1560-1SQ30
Wye-delta with overtravel function	3 x 1 NO	1 s – 20 s, 30 s – 600 s (overtravel)	AC/DC 24/AC 200 – 240 V	3RP1560-□SP30
Wye(star)-delta	1 NO + 1 NO	1 s – 20 s	AC 200 – 240 V / AC 380 – 440 V	3RP1574-□NM20
Wye(star)-delta	1 NO + 1 NO	1 s – 20 s	AC/DC 24/AC 100 – 127 V	3RP1574-□NQ30
Wye(star)-delta	1 NO + 1 NO	1 s – 20 s	AC/DC 24/AC 200 – 240 V	3RP1574-□NP30
Wye(star)-delta	1 NO + 1 NO	3 s – 60 s	AC 200 – 240 V / AC 380 – 440 V	3RP1576-□NM20
Wye(star)-delta	1 NO + 1 NO	3 s – 60 s	AC/DC 24/AC 100 – 127 V	3RP1576-□NQ30
Wye(star)-delta	1 NO + 1 NO	3 s – 60 s	AC/DC 24/AC 200 – 240 V	3RP1576-□NP30

Screw terminals **1**
Spring-type terminals **2**

3RP20 electronic timing relays in SIRIUS design 45 mm

8 functions	1 CO	0.05 s – 100 h	AC/DC 24/AC 100 – 127 V	3RP2005-□AQ30
8 functions	1 CO	0.05 s – 100 h	AC/DC 24/AC 200 – 240 V	3RP2005-□AP30
ON-delay	1 CO	0.05 s – 100 h	AC/DC 24/AC 100 – 127 V	3RP2025-□AQ30
ON-delay	1 CO	0.05 s – 100 h	AC/DC 24/AC 200 – 240 V	3RP2025-□AP30
16 functions ²⁾	2 CO	0.05 s – 100 h	AC/DC 24 – 240 V	3RP2005-□BW30

¹⁾ Positively driven and hard gold-plated relay contacts

²⁾ The 16 functions correspond to the 8 functions of the multifunctional timing relays with 1 1 CO; plus it is possible to adjust whether both CO contact outputs are to respond with a time delay or the 2nd CO contact is to switch immediately

Screw terminals **1**
Spring-type terminals **2**

7PV15 Timing Relays

Function	Contacts	Time range	Rated control supply voltage U_c	Order No.
7 functions	1 CO	0.05 s – 100 h	AC/DC 12 – 240 V	7PV1508-1AW30
Multifunction	2 CO	0.05 s – 100 h	AC/DC 12 – 240 V	7PV1508-1BW30
ON-delay	1 CO	0.5 s – 10 s	AC/DC 24/AC 100 – 127 V	7PV1512-1AQ30
ON-delay	1 CO	0.05 s – 1 s	AC/DC 24/AC 100 – 127 V	7PV1511-1AP30
ON-delay	1 CO	0.5 s – 10 s	AC/DC 24/AC 200 – 240 V	7PV1512-1AP30
ON-delay	1 CO	5 s – 100 s	AC/DC 24/AC 100 – 127 V	7PV1513-1AQ30
ON-delay	1 CO	5 s – 100 s	AC/DC 24/AC 200 – 240 V	7PV1513-1AP30
ON-delay	1 CO	0.05 s – 100 h	AC/DC 12 – 240 V	7PV1518-1AW30
ON-delay	1 CO	0.05 s – 100 h	AC/DC 90 – 127 V	7PV1518-1AJ30
ON-delay	1 CO	0.05 s – 100 h	AC/DC 180 – 240 V	7PV1518-1AN30
OFF-delay with auxiliary voltage	1 CO	0.05 s – 100 h	AC/DC 12 – 240 V	7PV1538-1AW30
OFF-delay without auxiliary voltage	1 CO	0.05 s – 100 s	AC/DC 12 – 240 V	7PV1540-1AW30
Clock generator	1 CO	0.05 s – 100 h	AC/DC 12 – 240 V	7PV1558-1AW30
Wye(star)-delta	1 NO + 1 NO	0.05 s – 100 h	AC/DC 12 – 240 V	7PV1578-1BW30

Function diagrams of timing relay functions

ON-delay

OFF-delay with auxiliary voltage

Flashing, starting with break

Passing make contact function

Passing break contact function with auxiliary voltage

Pulse shaping with auxiliary voltage

Additive ON-delay with auxiliary voltage

ON-delay + OFF-delay with auxiliary voltage

Fixed pulse after ON-delay

OFF-delay without auxiliary voltage

Clock generator

Wye(star)-delta switchover

Configuration information

- With the "clock-pulse" function, pulse and interval can be set separately, not so with the flashing function: Ratio pulse: interval 1:1
- "Time addition" function (volatile) with the multi-function relay: through activation of the start contact

- 1 Coil connections*
- 2 Contact terminals*
- 3 Function selector switch
- 4 Time selector switch
- 5 Time potentiometer

*Size PZ0 max. 1.5 mm²
 2.5 mm²

All 7PV15 timing relays in this enclosure design are suitable for snap mounting on TH 35 DIN rail acc. to IEC 60715.
 The enclosure conforms with DIN 43880, 1 TE.

SIRIUS 3RA2811/12/16 Function Modules

3RA2811/12 function modules for direct start for mounting on 3RT2 contactors with semiconductor output for size S00 and S0

Function	Time range	Rated control supply voltage U_s	Order No.
ON-delay	0.05 s – 100 s	AC/DC 24 – 240 V	3RA2811-□CW10
OFF-delay with auxiliary voltage	0.05 s – 100 s	AC/DC 24 – 240 V	3RA2812-□DW10

Screw terminals **1**
Spring-type terminals **2**

3RA2816 function modules for wye(star)-delta start

Wye-delta function	0.5 s – 60 s	AC/DC 24 – 240 V	3RA2816-0EW20
--------------------	--------------	------------------	---------------

No wiring required!

3RT1916-2/26-2 electronic timing relays for mounting on 3RT1 contactors

ON-delay	0.05 s – 1 s	AC/DC 24 – 66 V	3RT19□6-2CG11
	0.5 s – 10 s		3RT19□6-2CG21
	5 s – 100 s		3RT19□6-2CG31
ON-delay	0.05 s – 1 s	AC/DC 90 – 240 V	3RT19□6-2CH11
	0.5 s – 10 s		3RT19□6-2CH21
	5 s – 100 s		3RT19□6-2CH31
OFF-delay with auxiliary voltage	0.05 s – 1 s	AC/DC 24 – 66 V	3RT19□6-2DG11
	0.5 s – 10 s		3RT19□6-2DG21
	5 s – 100 s		3RT19□6-2DG31
OFF-delay with auxiliary voltage	0.05 s – 1 s	AC/DC 90 – 240 V	3RT19□6-2DH11
	0.5 s – 10 s		3RT19□6-2DH21
	5 s – 100 s		3RT19□6-2DH31

Size S00 **1**
Size S0 – S3 **2**

3RT1916-2/26-2 plug-on timing relays for wye(star)-delta start

Function	Time range	Rated control supply voltage U_s	Contacts	Order No.
Wye(star)-delta function	0.5 s – 30 s	AC/DC 24 V	1 NO delayed + 1 NO instantaneous	3RT19□6-2GJ51
		AC/DC 100 – 127 V	1 NO delayed + 1 NO instantaneous	3RT19□6-2GC51
		AC/DC 200 – 240 V	1 NO delayed + 1 NO instantaneous	3RT19□6-2GD51

Size S00 **1**
Size S0 – S* **2**

*S3 to S12, dependent on exact MLFB (see Catalog IC 10)

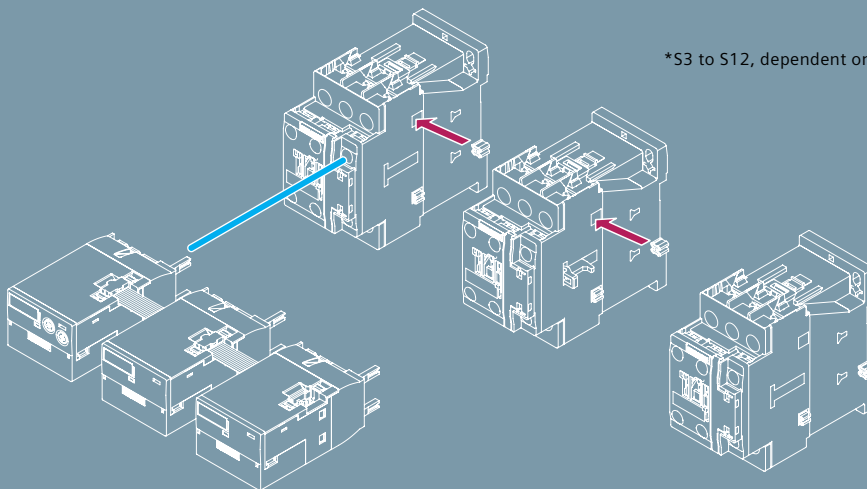

SIRIUS 3RA2813/14/15 Time-Delayed Auxiliary Switches

3RA2813/14/15 electronically delayed auxiliary switches for mounting on 3RT2 contactors for size S00 and S0, integrated varistor				
Function	Rated control supply voltage U_c	Time range	Contacts	Order No.
ON-delay	AC/DC 24 – 240 V	0.05 s – 100 s	1 CO	3RA2813-□AW10
ON-delay	AC/DC 24 – 240 V	0.05 s – 100 s	1 NO + 1 NC	3RA2813-□FW10
OFF-delay with auxiliary voltage	AC/DC 24 – 240 V	0.05 s – 100 s	1 CO	3RA2814-□AW10
OFF-delay with auxiliary voltage	AC/DC 24 – 240 V	0.05 s – 100 s	1 NO + 1 NC	3RA2814-□FW10
OFF-delay without auxiliary voltage	AC/DC 24 – 240 V	0.05 s – 100 s	1 CO	3RA2815-□AW10
OFF-delay without auxiliary voltage	AC/DC 24 – 240 V	0.05 s – 100 s	1 NO + 1 NC	3RA2815-□FW10

Screw terminals ¹
Spring-type terminals ²

3RT1916-2/26-2 electronically delayed auxiliary switches for mounting on 3RT1 contactors, integrated varistor				
ON-delay	AC/DC 24 V	0.05 s – 1 s	1 NO + 1 NC	3RT19□6-2EJ11
		0.5 s – 10 s	1 NO + 1 NC	3RT19□6-2EJ21
		5 s – 100 s	1 NO + 1 NC	3RT19□6-2EJ31
ON-delay	AC/DC 100 – 127 V	0.05 s – 1 s	1 NO + 1 NC	3RT19□6-2EC11
		0.5 s – 10 s	1 NO + 1 NC	3RT19□6-2EC21
		5 s – 100 s	1 NO + 1 NC	3RT19□6-2EC31
ON-delay	AC/DC 200 – 240 V	0.05 s – 1 s	1 NO + 1 NC	3RT19□6-2ED11
		0.5 s – 10 s	1 NO + 1 NC	3RT19□6-2ED21
		5 s – 100 s	1 NO + 1 NC	3RT19□6-2ED31
OFF-delay without auxiliary voltage	AC/DC 24 V	0.05 s – 1 s	1 NO + 1 NC	3RT19□6-2FJ11
		0.5 s – 10 s	1 NO + 1 NC	3RT19□6-2FJ21
		5 s – 100 s	1 NO + 1 NC	3RT19□6-2FJ31
OFF-delay without auxiliary voltage	AC/DC 100 – 127 V	0.05 s – 1 s	1 NO + 1 NC	3RT19□6-2FK11
		0.5 s – 10 s	1 NO + 1 NC	3RT19□6-2FK21
		5 s – 100 s	1 NO + 1 NC	3RT19□6-2FK31
OFF-delay without auxiliary voltage	AC/DC 200 – 240 V	0.05 s – 1 s	1 NO + 1 NC	3RT19□6-2FL11
		0.5 s – 10 s	1 NO + 1 NC	3RT19□6-2FL21
		5 s – 100 s	1 NO + 1 NC	3RT19□6-2FL31
OFF-delay with auxiliary voltage	AC/DC 24 V	0.5 s – 10 s	1 CO	3RT1916-2LJ51
OFF-delay with auxiliary voltage	AC/DC 100 – 127 V	0.5 s – 10 s	1 CO	3RT1916-2LC51
OFF-delay with auxiliary voltage	AC/DC 200 – 240 V	0.5 s – 10 s	1 CO	3RT1916-2LD51

Size S00 ¹
Size S0 – S* ²

*S3 to S12, dependent on exact MLFB (see Catalog IC 10)

SIRIUS 3UG4 Monitoring Relays

3UG451, 3UG461 monitoring relays for line monitoring										
Phase sequence	Phase failure	Asymmetry	Hysteresis	Under-voltage	Over-voltage	N-cond. monitoring	Delay times	Contacts	Rated control supply voltage $U_s^{1)}$	Order No.
22.5 mm width, 3UG4614 to 3UG4618 digital-adjustable, with fault memory and LC display										
Yes	Condit. ²⁾	–	–	–	–	–	–	1 CO	AC 160–260 V ¹⁾ AC 320–500 V ¹⁾ AC 420–690 V ¹⁾	3UG4511-□AN20 3UG4511-□AP20 3UG4511-□AQ20
								2 CO	AC 160–260 V ¹⁾ AC 320–500 V ¹⁾ AC 420–690 V ¹⁾	3UG4511-□BN20 3UG4511-□BP20 3UG4511-□BQ20
Yes	Yes	10 %	–	–	–	–	–	1 CO	AC 160–690 V ¹⁾	3UG4512-□AR20
								2 CO	AC 160–690 V ¹⁾	3UG4512-□BR20
Yes	Yes	20 %	5 %	80 % of U_s	–	–	OFF-delay 0.1 s–20 s	2 CO	AC 160–690 V ¹⁾	3UG4513-□BR20
Selectable	Yes	0 or 5–20 %	1–20 V	160–690 V	–	–	ON- and OFF-delay 0.1 s–20 s	2 CO	AC 160–690 V ¹⁾	3UG4614-□BR20
Selectable	Yes	Via threshold values	1–20 V	160–690 V	160–690 V	–	0.1 s–20 s each for U_{min} and U_{max}	1 CO each for U_{min} and U_{max}	AC 160–690 V ¹⁾	3UG4615-□CR20
Selectable	Yes	Via threshold values	1–20 V	90–400 V against N	90–400 V against N	Yes	0.1 s–20 s each for U_{min} and U_{max}	1 CO each for U_{min} and U_{max}	AC 90–400 V ¹⁾ against N	3UG4616-□CR20
Autom. correction	Yes	0 or 5–20 %	1–20 V	160–690 V	160–690 V	–	OFF-delay 0.1 s–20 s	1 CO each for line faults and phase sequence	AC 160–690 V ¹⁾	3UG4617-□CR20
Autom. correction	Yes	0 or 5–20 %	1–20 V	90–400 V against N	90–400 V against N	Yes	OFF-delay 0.1 s–20 s	1 CO each for line faults and phase sequence	AC 90–400 V ¹⁾ against N	3UG4618-□CR20

3UG463 monitoring relays for single-phase voltage monitoring						
Measuring range	Hysteresis	Contacts	Delay time	Rated control supply voltage $U_s^{1)}$	Order No.	
22.5 mm width, all devices digital-adjustable and with LC display, connectable fault memory, simultaneous monitoring for voltage overshoot and undershoot over the entire measuring range						
AC/DC 0.1–60 V	0.1–30 V	1 CO	0.1 s–20 s	AC/DC 24 V	3UG4631-□AA30	
				AC/DC 24–240 V	3UG4631-□AW30	
AC/DC 10–600 V	0.1–300 V	1 CO	0.1 s–20 s	AC/DC 24 V	3UG4632-□AA30	
				AC/DC 24–240 V	3UG4632-□AW30	
AC/DC 17–275 V	0.1–150 V	1 CO	0.1 s–20 s	Intrinsic supply	3UG4633-□AL30	

3UG4815/16 monitoring relays for line and three-phase voltage monitoring							
	ON-delay	Stabilization time	Tripping delay time	Hysteresis	Contacts	Adjustable monitoring range	Order No.
22.5 mm width, adjustable via IO-Link or locally, monitoring of phase sequence, phase failure, phase asymmetry, overvoltage and undervoltage							
IO-Link 3 phases	–	OFF 0.1–999.9 s	OFF 0.1–999.9 s	Voltage: 0–20 V Asymmetry: 0–20 %	1 CO 1 Q in SIO mode	AC 160–690 V ¹⁾	3UG4815-□AA40
						AC 90–400 V ¹⁾ against N	3UG4816-□AA40
3UG4832 monitoring relays for single-phase voltage monitoring							
22.5 mm width, adjustable via IO-Link or locally, monitoring of overvoltage and undervoltage							
1 phase	OFF 0.1–999.9 s	–	OFF 0.1–999.9 s	OFF 1–300 V	1 CO 1 Q in SIO mode	AC 10–600 V	3UG4832-□AA40

1) Absolute limit values

2) Return voltage due to coupling of the individual phases

Screw terminals **1**
Spring-type terminals **2**

The 3UG4511 device is not able to detect phase failures reliably.

Loads connected in the three-phase network, e.g. motor windings, lamps, transformers, ensure the individual phases' connection.

Due to this network coupling, a return voltage is always present on the device terminal of the failed phase.

SIRIUS 3RR2 Monitoring Relays

3RR21 monitoring relays						
Size	Measuring range	Hysteresis	Contacts	ON-delay	Rated control supply voltage U_s	Order No.
All devices analog-adjustable, closed-circuit principle, 2-phase current monitoring, apparent current monitoring, tripping delay 0–30 s, automatic or manual RESET						
S00	1.6–16 A	6.25% of the threshold value	1 CO	0–60 s	AC/DC 24 V	3RR2141-□AA30
					AC/DC 24–240 V	3RR2141-□AW30
S0	4–40 A	6.25% of the threshold value	1 CO	0–60 s	AC/DC 24 V	3RR2142-□AA30
					AC/DC 24–240 V	3RR2142-□AW30

Screw terminals 1
Spring-type terminals 2

3RR22 monitoring relays							
Size	Measuring range	Hysteresis	Contacts	ON-delay	Restart delay	Rated control supply voltage U_s	Order No.
All devices digital-adjustable, LC display, open- or closed-circuit principle, 3-phase current monitoring, active current or apparent current monitoring, delay time 0–30 s, automatic or manual RESET, phase sequence monitoring, residual current monitoring, blocking current monitoring, separate settings for warning and alarm thresholds							
S00	1.6–16 A	0.1–3 A	1 CO 1 Q	0–99 s	0–300 min	AC/DC 24 V	3RR2241-□FA30
						AC/DC 24–240 V	3RR2241-□FW30
S0	4–40 A	0.1–8 A	1 CO 1 Q	0–99 s	0–300 min	AC/DC 24 V	3RR2242-□FA30
						AC/DC 24–240 V	3RR2242-□FW30

Screw terminals 1
Spring-type terminals 2

3RR24 monitoring relays							
Size	Measuring range	Hysteresis	Contacts	ON delay	Restart delay	Rated control supply voltage U_s	Order No.
All devices adjustable locally and via IO-Link, LC display, open- or closed circuit principle, 3-phase current monitoring, active current or apparent current monitoring, delay time 0–30 s, automatic or manual RESET, current asymmetry monitoring, phase sequence monitoring, residual current monitoring, blocking current monitoring, operating hours counter, switching cycle counter, separate settings for warning and alarm thresholds							
S00	1.6–16 A	0.1–3 A	1 CO 1 Q (in SIO mode)	OFF 0.1–999.9 s	OFF 0.1–300 min	DC 24 V	3RR2441-□AA40
S0	4–40 A	0.1–8 A	1 CO 1 Q (in SIO mode)	OFF 0.1–999.9 s	OFF 0.1–300 min	DC 24 V	3RR2442-□AA40

Screw terminals 1
Spring-type terminals 2

Adapter for stand-alone mounting for separate mounting of the monitoring relays on DIN rails	
Size	Order No.
S00	3RU2916-3A□01
S0	3RU2926-3A□01

Screw terminals A
Spring-type terminals C

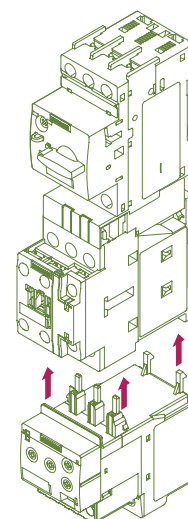

SIRIUS 3UG4 Monitoring Relays

3UG4621/22 monitoring relays for single-phase current monitoring

Measuring range	Hysteresis	Contacts	ON-delay	Tripping delay	Rated control supply voltage U_s	Order No.
22.5 mm width, all devices digital-adjustable and with LC display, connectable fault memory, simultaneous monitoring for current overshoot and undershoot over the entire measuring range						
AC/DC 3 – 500 mA	0.1 – 250 mA	1 CO	0.1 – 20 s	0.1 – 20 s	AC/DC 24 V ¹⁾	3UG4621-□AA30
					AC/DC 24 – 240 V ²⁾	3UG4621-□AW30
AC/DC 0.05 – 10 A	0.01 – 5 A	1 CO	0.1 – 20 s	0.1 – 20 s	AC/DC 24 V ¹⁾	3UG4622-□AA30
					AC/DC 24 – 240 V ²⁾	3UG4622-□AW30

¹⁾ No galvanic isolation. Load supply voltage 24 V.

²⁾ Galvanic isolation between control circuit and measuring circuit. Load supply voltage for safe isolation max. 300 V, for simple separation max. 500 V.

Screw terminals **1**
Spring-type terminals **2**

3UG4641 monitoring relays for power factor and active current monitoring

Measuring range for power factor	Measuring range for active current I_{res}	Hysteresis with power factor	Hysteresis with active current	Contacts	ON-delay time	Tripping delay time	Rated control supply voltage $U_s^{1)}$	Order No.
22.5 mm width, device digitally adjustable and with LC display, connectable fault memory, simultaneous power factor and active current monitoring over the entire measuring range								
0.1 – 0.99 (PF)	0.2 – 10.0 A	0.1 (PF)	0.1 – 2.0 A	1 CO + 1 CO	0 – 99 s	0.1 – 20.0 s	AC 90 – 690 V ₁₎	3UG4641-□CS20

1) Absolute limit values

Screw terminals **1**
Spring-type terminals **2**

3UG4822 monitoring relays for single-phase current monitoring

Measuring range	Hysteresis	Contacts	ON-delay time	Tripping delay time	Order No.
22.5 mm width, adjustable via IO-Link or locally, monitoring of overcurrent and undercurrent, scaling factor for considering external 1 A / 5 A instrument transformer adjustable					
0.05 – 10 A	OFF 0.01 – 5 A	1 CO 1 Q in SIO mode	OFF 0.1 – 999.9 s	OFF 0.1 – 999.9 s	3UG4822-□AA40

3UG4841 monitoring relays for power factor and active current monitoring

22.5 mm width, adjustable via IO-Link or locally, monitoring of phase sequence, phase failure, phase asymmetry, overvoltage and undervoltage					
cos phi: 0.1 – 0.99 Current: 0.2 – 10 A	cos phi: OFF/0.1 – 0.20 Current: OFF/0.1 – 3 A	1 CO 1 Q in SIO mode	OFF 0.1 – 999.9 s	OFF 0.1 – 999.9 s	3UG4841-□CA40

Screw terminals **1**
Spring-type terminals **2**

IO-Link

Current and power factor dependent on the motor load

Rule of thumb:

The power factor changes significantly below the rated load; the current increases disproportionately above the rated load.

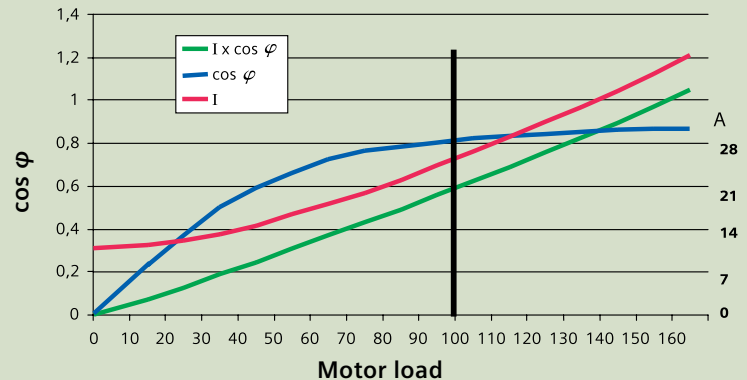

The active current I_{res} indicates a linear correlation between the motor load and the measured value over the entire measuring range.

SIRIUS 3UG4 Monitoring Relays

3UG4624 monitoring relays for residual current monitoring							
Measurable current	Adjustable response value current	Switching hysteresis	Adjustable response delay time	Control supply voltage at 50 Hz at AC rated value	Control supply voltage at 60 Hz at AC rated value	Control supply voltage at DC rated value	Order No.
22.5 mm width, digitally adjustable and with LC display, permanent self-monitoring, monitoring of a warning threshold and limit value overshoot, for 3UL23 residual current transformer							
0.01–43 A	0.03–40 A	0–50 %	0–20 s	24–240 V	24–240 V	24–240 V	3UG4625-□CW30

Screw terminals ①
Spring-type terminals ②

IO-Link	3UG4825 monitoring relays for residual current monitoring					
	Measurable current	Adjustable response value current	Switching hysteresis	Adjustable response delay time	Control supply voltage at DC rated value	Order No.
	22.5 mm width, digitally adjustable and with LC display, permanent self-monitoring, monitoring of a warning threshold and limit value overshoot, for 3UL23 residual current transformer					
	0.01–43 A	0.03–40 A	0–50 %	OFF 0.1–999.9 s	24 V	3UG4825-□CA40

Screw terminals ①
Spring-type terminals ②

3UL23 residual current transformers for residual current monitoring			
Diameter of bushing opening	Max. rated current per phase	Max. connectable conductor cross-section of terminal	Order No.
Detection of residual currents in machines and systems			
35 mm	85 A	2.5 mm ²	3UL2302-1A
55 mm	150 A		3UL2303-1A
80 mm	225 A		3UL2304-1A
110 mm	400 A		3UL2305-1A
140 mm	500 A		3UL2306-1A
210 mm	630 A	4 mm ²	3UL2307-1A

3UG4581 monitoring relays for insulation monitoring for non-grounded AC networks						
Rated line voltage U_n	System leakage capacitance	Output relay	Meas. range U_e	Rated control supply voltage U_s	Cable break detection in the measuring range	Order No.
AC 0–400 V	max. 10 μ F	1 CO	1–100 k Ω	AC/DC 24–240 V	–	3UG4581-1AW30

3UG4582/83 monitoring relays for insulation monitoring for non-grounded DC and AC voltage networks						
Rated line voltage U_n	System leakage capacitance	Output relay	Meas. range U_e	Rated control supply voltage U_s	Cable break detection in the measuring range	Order No.
AC 0–250 V, DC 0–300 V	max. 10 μ F	1 CO	1–100 k Ω	AC/DC 24–240 V	Yes	3UG4582-1AW30
AC 0–400 V, DC 0–600 V ²⁾	max. 20 μ F	2 CO or 1 CO + 1 CO adjustable	1–100 k Ω , 2–200 k Ω for 2nd limit value, adjustable	AC/DC 24–240 V	Yes adjustable	3UG4583-1CW30

Series module for 3UG4583
for expansion of the line voltage range to max. 690 V AC and 1000 V DC

3UG4983-1A

Covers for monitoring relays for insulation monitoring		
Application	Version	Order No.
For 3UG4581, 3UG4582	Sealable, transparent cover	3UG4981-0C
For 3UG4583	Sealable, transparent cover	3UG4983-0C

2) With 3UG49 83-1A series module also suitable for insulation monitoring of IT networks up to 690 V AC and 1000 V DC.

SIRIUS 3UG4 Monitoring Relays

Überwachungsrelais 3UG4501 for 1- and 2-point level monitoring of conductive liquids

Sensitivity	Contacts	Tripping delay	Width	Rated control supply voltage U_s	Order No.
2–200 k Ω	1 CO	0.5–10 s	22.5 mm	AC/DC 24 V	3UG4501-□AA30
				AC/DC 24–240 V	3UG4501-□AW30

Probes for level monitoring, max. operating temperature 90 °C, max. operating pressure 10 bar

Description	Cable connection	Number of poles	Order No.
Wire electrode, 500 mm long, with teflon insulation	3 x 0.5 mm ² , 2 m	3-pole	3UG3207-3A
	2 x 0.5 mm ² , 2 m	2-pole	3UG3207-2A
Wire electrode for lateral installation	3 x 0.5 mm ² , 2 m	2-pole	3UG3207-2B
	2 x 0.5 mm ² , 2 m	1-pole	3UG3207-1B
Rod electrode, stable	2 x 0.5 mm ² , 2 m	1-pole	3UG3207-1C

Screw terminals **1**

Spring-type terminals **2**

3UG4651 monitoring relays for monitoring of speed undershoot and overshoot

Meas. range pulses / min	Contacts	ON-delay time	Tripping delay	Width	Rated control supply voltage U_s	Order No.
0.1–2200 (0.0017–36.67 Hz)	1 CO	1–900 s	0.1–99.9 s	22.5 mm	AC/DC 24 V	3UG4651-□AA30
					AC/DC 24–240 V	3UG4651-□AW30

Screw terminals **1**

Spring-type terminals **2**

3UG4851 monitoring relays for monitoring of speed undershoot and overshoot

Meas. range pulses / min	Contacts	ON-delay time	OFF-delay time	Hysteresis	Order No.
Monitoring for speed overshoot and undershoot, scaling factor for consideration of multiple incremental encoders per rotation					
0.1 – 2200 (0,0017 – 36,67 Hz)	1 CO 1 Q in SIO mode	OFF 0.1 – 999.9 s	OFF 0.1 – 999.9 s	OFF 0.1 – 99.9 rpm	3UG4851-□AA40

Screw terminals **1**

Spring-type terminals **2**

SIRIUS 3RN1 Thermistor Motor Protection

Thermistor motor protection relays for PTC thermistors (PTCs Type A)					
All devices except for 24 V AC/DC feature galvanic isolation					
Version	RESET	Contacts	Rated control supply voltage U_s	Order No.	
Compact evaluation devices, 22.5 mm width, monostable, closed-circuit principle, 1 LED					
Terminal A1 is bridged with the root of the CO contact	Automatic	1 CO	AC/DC 24 V	3RN1000-□AB00	
			AC 110 V	3RN1000-□AG00	
			AC 230 V	3RN1000-□AM00	
Standard evaluation devices, 22.5 mm width, monostable, closed-circuit principle, 2 LEDs					
	Automatic	1 NO + 1 NC	AC/DC 24 V	3RN1010-□CB00	
			AC 110 V	3RN1010-□CG00	
			AC 230 V	3RN1010-□CM00	
			AC/DC 24 – 240 V	3RN1010-□CW00	
		2 CO	AC/DC 24 V	3RN1010-□BB00	
			AC 110 V	3RN1010-□BG00	
	2 CO, hard gold-pl.	AC/DC 24 V	3RN1010-□GB00		
		AC/DC 24 V	3RN1010-□GB00		
	Manual/remote ³⁾	1 NO + 1 NC	AC/DC 24 V	3RN1011-□CB00	
			AC 110/230 V	3RN1011-□CK00	
	Short-circuit detection in the sensor circuit	Manual/remote ³⁾	2 CO	AC/DC 24 V	3RN1011-□BB00
				AC 110 V	3RN1011-□BG00
AC 230 V				3RN1011-□BM00	
2 CO, hard gold-pl.			AC/DC 24 V	3RN1011-□GB00	
Prot. against volt. failure ²⁾	Manual/automatic/remote	1 NO + 1 NC	AC/DC 24 V	3RN1012-□CB00	
			AC 110/230 V	3RN1012-□CK00	
Prot. against volt. failure ²⁾ Short-circuit detection in the sensor circuit	Manual/automatic/remote	2 CO	24 V AC/DC	3RN1012-□BB00	
			AC 110 V	3RN1012-□BG00	
			AC 230 V	3RN1012-□BM00	
		2 CO, hard gold-pl.	AC/DC 24 V	3RN1012-□GB00	
Prot. against volt. failure ²⁾ , detection and indication of short circuit and wire breakage in the sensor circuit, wide voltage with screw terminals with safe isolation ¹⁾	Manual/automatic/remote	2 CO	AC/DC 24 V	3RN1013-□BB00	
			AC/DC 24 – 240 V	3RN1013-1BW10	
			AC/DC 24 – 240 V	3RN1013-2BW00	
		2 CO, hard gold-pl.	AC/DC 24 – 240 V	3RN1013-1GW10	
			AC/DC 24 – 240 V	3RN1013-2GW00	
For bimetal sensors (without short-circuit detection)	Manual/remote	2 CO	AC 230 V	3RN1014-1BM00	
Evaluation units for 2 sensor circuits, warning and disconnection, 22.5 mm width, monostable, closed-circuit principle, 3 LEDs					
Test/RESET button, prot. against volt. failure ²⁾ ; evaluation circuit for “warning” works with NO contact in closed-circuit principle	Manual/automatic/remote	1 NO + 1 NC	AC/DC 24 – 240 V	3RN1022-□DW00	
Evaluation units for 6 sensor circuits, multi-motor protection, 45 mm width, monostable, closed-circuit principle, 8 LEDs					
Test/RESE button, prot. against volt. failure ²⁾	Manual/automatic/remote	1 NO + 1 NC	AC/DC 24 – 240 V	3RN1062-□CW00	
Bistable evaluation units, 22.5 mm width					
Test/RESET button, prot. against volt. failure ²⁾ , detection and indication of short-circuit and wire breakage in sensor circuit, bistable version, no tripping on failure of control supply voltage	Manual/automatic/remote	2 CO	AC/DC 24 – 240 V	3RN1013-□BW01	

¹⁾ Safe isolation up to 300 V acc. to DIN/VDE 0106, IEC 60947-1

²⁾ For information on protection against voltage failure see Catalog IC 10

³⁾ Reset using RESET button or interruption of control supply voltage possible

Screw terminals

Spring-type terminals

SIRIUS 3RS10/3 RS11 Temperature Monitoring Relays

3RS10/3RS11 temperature monitoring relays				
Sensor	Function	Measuring range	Rated control supply voltage U_s	Order No.
Analog-adjustable, 1 sensor, 1 threshold value, 22.5 mm width; analog closed-circuit principle; non-retentive; 1 NO + 1 NC				
PT100 (resistance sensor)	Overshoot	- 50 ... + 50 °C	AC/DC 24 V	3RS1000-□CD00
			AC 110/230 V	3RS1000-□CK00
		0 ... + 100 °C	AC/DC 24 V	3RS1000-□CD10
			AC 110/230 V	3RS1000-□CK10
		0 ... + 200 °C	AC/DC 24 V	3RS1000-□CD20
	AC 110/230 V		3RS1000-□CK20	
	Undershoot	- 50 ... + 50 °C	AC/DC 24 V	3RS1010-1CD00
			AC 110/230 V	3RS1010-1CK00
		0 ... + 100 °C	AC/DC 24 V	3RS1010-1CD10
			AC 110/230 V	3RS1010-1CK10
0 ... + 200 °C		AC/DC 24 V	3RS1010-1CD20	
	AC 110/230 V	3RS1010-1CK20		
Type J (thermocouple)	Overshoot	0 ... + 200 °C	AC/DC 24 V	3RS1100-□CD20
			AC 110/230 V	3RS1100-1CK20
		0 ... + 600 °C	AC/DC 24 V	3RS1100-1CD30
			AC 110/230 V	3RS1101-1CK30
Type K (thermocouple)	Overshoot	0 ... + 200 °C	AC/DC 24 V	3RS1101-1CD20
			AC 110/230 V	3RS1101-1CK20
		0 ... + 600 °C	AC/DC 24 V	3RS1101-1CD30
			AC 110/230 V	3RS1101-1CK30
		+ 500 ... + 1000 °C	AC/DC 24 V	3RS1101-1CD40
			AC 110/230 V	3RS1101-1CK40
Analog-adjustable for warning and disconnection 2 threshold values), 22.5 mm width; selectable open-/closed-circuit principle; non-retentive; 1 NO + 1 CO				
PT100 (resistance sensor)	Overshoot	- 50 ... + 50 °C	AC/DC 24 V	3RS1020-1DD00
			AC/DC 24 – 240 V	3RS1020-1DW00
		0 ... + 100 °C	AC/DC 24 V	3RS1020-1DD10
			AC/DC 24 – 240 V	3RS1020-1DW10
		0 ... + 200 °C	AC/DC 24 V	3RS1020-1DD20
	AC/DC 24 – 240 V		3RS1020-□DW20	
	Undershoot	- 50 ... + 50 °C	AC/DC 24 V	3RS1030-1DD00
			AC/DC 24 – 240 V	3RS1030-1DW00
		0 ... + 100 °C	AC/DC 24 V	3RS1030-1DD10
			AC/DC 24 – 240 V	3RS1030-1DW10
0 ... + 200 °C		AC/DC 24 V	3RS1030-□DD20	
	AC/DC 24 – 240 V	3RS1030-1DW20		
Type J (thermocouple)	Overshoot	0 ... + 200 °C	AC/DC 24 V	3RS1120-□DD20
			AC/DC 24 – 240 V	3RS1120-1DW20
		0 ... + 600 °C	AC/DC 24 V	3RS1120-1DD30
			AC/DC 24 – 240 V	3RS1120-1DW30
Type K (thermocouple)	Overshoot	0 ... + 200 °C	AC/DC 24–240 V	3RS1121-1DW20
		0 ... 600 °C	AC/DC 24–240 V	3RS1121-1DW30
		+ 500 ... + 1000 °C	AC/DC 24 V	3RS1121-1DD40

Analog-adjustable evaluation units with one and two threshold values. With analog-adjustable devices, the threshold values and the hysteresis from 2 to 20% are set via a rotary potentiometer. The adjustable hysteresis only applies for threshold 1. For the 2nd threshold a fixed hysteresis of 5% applies. This product range has been developed for applications for which an adjustment accuracy of ±5% is sufficient.

Screw terminals **1**
Spring-type terminals **2**

Suitable sensors are available via www.siemens.com/temperature

SIRIUS 3RS10/11/20/21 and 3RS14/15 Temperature Monitoring Relays

3RS10/11 and 3RS20/21 temperature monitoring relays			
Sensor	Measuring range (Meas. range limit is sensor-dependent)	Rated control supply voltage U_c AC 50/60 Hz	Order No.
Digital-adjustable, 1 sensor, 2 threshold values, 45 mm width; 1 CO + 1 CO + 1 NO, storage function possible through external bridge; device parameters are non-volatile			
PT100/1000; KTY83/84; NTC (resistance sensor) ¹⁾	-50...+500 °C	AC/DC 24 V	3RS1040-□GD50
		AC/DC 24 – 240 V	3RS1040-□GW50
	-58...+932 °F	AC/DC 24 V	3RS2040-□GD50
		AC/DC 24 – 240 V	3RS2040-□GW50
Type J, K, T, E, N (thermocouple)	-99...+999 °C	AC/DC 24 V	3RS1140-□GD60
		AC/DC 24 – 240 V	3RS1140-□GW60
	-99...+1830 °F	AC/DC 24 V	3RS2140-□GD60
		AC/DC 24 – 240 V	3RS2140-□GW60
Digital-adjustable, 1 sensor, 2 threshold values, 45 mm width; 1 CO + 1 CO + 1 NO, tripping state and device parameters are non-volatile			
PT100/1000; KTY83/84; NTC (resistance sensor) ¹⁾	-50...+750 °C	AC/DC 24 V	3RS1042-□GD70
		AC/DC 24 – 240 V	3RS1042-□GW70
Type J, K, T, E, N, R, S, B (thermocouple)	-99...+1800 °C	AC/DC 24 V	3RS1142-□GD80
		AC/DC 24 – 240 V	3RS1142-□GW80

Motor monitoring relays, digitally adjustable for up to 3 sensors, 45 mm width; 1 CO + 1 CO + 1 NO				
Sensor	Number of sensors	Measuring range	Rated control supply voltage U_c	Order No.
PT100/1000; KTY83/84; NTC (resistance sensor) ¹⁾	1 to 3 sensors	-50...+500 °C	AC/DC 24 – 240 V	3RS1041-□GW50
		-58...+932 °F	AC/DC 24 – 240 V	3RS2041-□GW50

¹⁾ NTC type: B57227-K333-A1 (100 °C: 1,8 kΩ; 25 °C: 32,762 kΩ)

Screw terminals 1
Spring-type terminals 2

3RS14/15 temperature monitoring relays						
	ON-delay time	Tripping delay time	Hysteresis	Contacts	Adjustable monitoring range	Order No.
IO-Link Monitoring of temperatures for overshoot and undershoot, 45 mm width, 1 CO per limit value, 1 CO for sensor and device monitoring	0 ... 999.9 s	0 ... 999.9 s	0 ... 99 K	3 CO	-50...+750 °C/ -58...+1382 °F	3RS1440-□HB50
					-99...+1800 °C/ -146,2...+3272 °F	3RS1441-□HB50
						3RS1540-□HB80
1 resistance sensor Up to 3 resistance sensors 1 thermocouple	PT100/1000 KTY83/84 NTC ¹⁾	Type J, K, T, E, N, S, R, B				

¹⁾ NTC type B57227-K333-A1 (100 °C: 1,8 kΩ; 25 °C: 32,762 kΩ).

Screw terminals 1
Spring-type terminals 2

The short-circuit and wire break detection as well as the measuring range are limited, depending on sensor type:

Measuring ranges in °C for thermocouples					
Sensor type	Short circuit	Wire break- age	3RS1140 meas. range in °C	3RS1142 Meas. range in °C	3RS1540 Meas. range in °C
J	-	✓	-99...999	-99...1200	-99...1350
K	-	✓	-99...999	-99...1350	-99...1300
T	-	✓	-99...400	-99...400	-99...1200
E	-	✓	-99...999	-99...999	-99...999
N	-	✓	-99...999	-99...999	-99...400
S	-	✓	-	0...1750	0...1750
R	-	✓	-	0...1750	0...1750
B	-	✓	-	400...1800	400...1800

Measuring ranges in °C for resistance sensors				
Sensor type	Short circuit	Wire breakage	3RS1140, 3RS1141 meas. range in °C	3RS1042, 3RS1440, 3RS1441 meas. range in °C
PT100	✓	✓	-50...500	-50...750
PT1000	✓	✓	-50...500	-50...500
KTY83-110	✓	✓	-50...175	-50...175
KTY84	✓	✓	-40...300	-40...300
NTC ¹⁾	✓	-	80...160	80...160

¹⁾ NTC type: B57227-K333-A1 (100 °C: 1.8 kΩ; 25 °C: 32.762 kΩ)

SIRIUS 3TX700/701 Coupling Relays

3TX7002/03 coupling relays – for small line distances or flat control cabinets

Output couplers with relay output (compact enclosure)

Output	Rated control supply voltage U_s	W x H x D in mm	Hard gold plating	Order No.
1 NO	AC/DC 24 V	11.5 x 60 x 62	–	3TX700□-1AB00
		11.5 x 60 x 62	Yes	3TX7002-1AB02
1 CO	AC/DC 24 V	17.5 x 60 x 62	–	3TX700□-1BB00
	230 V AC/DC	17.5 x 60 x 62	–	3TX7002-1BF00
2 NO	AC/DC 24 V	22.5 x 60 x 62	–	3TX700□-1CB00
2 CO	AC/DC 24 V	22.5 x 60 x 62	Yes	3TX7002-1FB02

Input couplers with relay output (compact enclosure)

1 NO	230 V AC/DC	11.5 x 60 x 62	–	3TX700□-2AF00
	230 V AC/DC	11.5 x 60 x 62	–	3TX7002-2AF05
	AC/DC 110 V	11.5 x 60 x 62	–	3TX7002-2AE00
	AC/DC 24 V	11.5 x 60 x 62	–	3TX7002-2AB00
1 CO	230 V AC/DC	17.5 x 60 x 62	Yes	3TX7002-2BF02

Accessories

Connection cable with 24 clamping points for 3TX70	3TX7004-8BA00
Connection comb with 24 clamping points for 3TX7004 with 6.2 mm width and screw terminals	3TX7004-8AA00

Screw terminals **2**
Spring-type terminals **3**

3TX7004 / 05 coupling relays, not pluggable

Output couplers with relay output (6.2 mm width)

Contacts	Rated control supply voltage U_s	W x H x D in mm ¹⁾	Hard gold plating	M-0-A switch	Order No.
1 CO	AC/DC 24 V	6.2 x 80 x 84	–	–	3TX700□-1LB00
			Yes	–	3TX700□-1LB02
		12.5 x 80 x 84	–	Yes	3TX7004-1BB10
	AC/DC 110 V	6.2 x 80 x 84	–	–	3TX7005-1LN00
	230 V AC/DC	6.2 x 80 x 84	–	–	3TX700□-1LF00
12.5 x 80 x 84		–	–	3TX7004-1BF05 ²⁾	
1 NO	AC/DC 24 V	6.2 x 80 x 84	–	–	3TX700□-1MB00
	230 V AC/DC	6.2 x 80 x 84	–	–	3TX700□-1MF00

3TX7004/05 – input couplers with relay output (6.2 mm width)

1 NO	230 V AC/DC	6.2 x 80 x 84	Yes	–	3TX700□-2MF02
	AC/DC 110 V	6.2 x 80 x 84	Yes	–	3TX7004-2ME02
	AC/DC 24 V	6.2 x 80 x 84	Yes	–	3TX700□-2MB02

- 1) With 3TX7004 (screw terminals), the height amounts to 79 mm
2) For long cable lengths up to 350 m

Screw terminals **4**
Spring-type terminals **5**

3TX7014 / 15 coupling relays with relay output, plug-in

Coupling relays with plug-in relays (6,2 mm width)

Contacts	Rated control supply voltage U_s	W x H x D in mm	Hard gold plating	M-0-A switch	Order No.
1 NO	DC 24 V	6.2 x 89.5 x 92	–	–	3TX701□-1AM00
1 CO	DC 24 V	6.2 x 89.5 x 92	–	–	3TX701□-1BM00
	AC/DC 24 V	6.2 x 89.5 x 92	–	–	3TX701□-1BB00
	115 V AC/DC	6.2 x 89.5 x 92	–	–	3TX701□-1BE00
	230 V AC/DC	6.2 x 89.5 x 92	–	–	3TX701□-1BF00

Coupling relays with plug-in relays (6.2 mm width)

1 CO	DC 24 V	6.2 x 89.5 x 92	Yes	–	3TX701□-1BM02
	AC/DC 24 V	6.2 x 89.5 x 92	Yes	–	3TX701□-1BB02
	115 V AC/DC	6.2 x 89.5 x 92	Yes	–	3TX701□-1BE02
	230 V AC/DC	6.2 x 89.5 x 92	Yes	–	3TX701□-1BF02

Accessories

Wiring comb 16-pole for 3TX7014 and 3TX7015 plug-in base couplers	3TX7014-7AA00
Potential barrier for 3TX70 plug-in base couplers	3TX7014-7CE00

Configuration information



When selecting the coupling links, the maximum permissible cable length has to be observed with rated control supply voltages of 110 V AC and 230 V AC. The special 3TX700-...05 type can be used for longer cables.

Screw terminals **4**
Spring-type terminals **5**

SIRIUS 3TX700 and 3RS18 Coupling Relays



3TX7004 / 05 coupling relays with semiconductor output, not pluggable							
Output couplers with semiconductor output – in narrow, space-saving design, 1 NO contact (6.2 mm width)							
Rated control supply voltage U_c	W x H x D in mm ¹⁾	Switching current max.	Switching voltage	Min. load current	Short-time load carrying capacity	M-0-A switch	Order No.
DC 24 V	6.2 x 80 x 84	0.5 A	≤ DC 48 V	–	1.5 A/20 ms	–	3TX700□-3AB04
	6.2 x 80 x 84	1.5 A	≤ DC 11 – 30 V	–	Short-circuit-pr.	–	3TX700□-3PB54
	6.2 x 80 x 84	3 A	≤ DC 30 V	–	Short-circuit-pr.	–	3TX700□-3PB74
	12.5 x 80 x 84	5 A	≤ DC 30 V	0.5 A	Short-circuit-pr.	–	3TX700□-3AC04
	12.5 x 80 x 84	5 A	≤ DC 30 V	0.5 A	Short-circuit-pr.	Yes	3TX700□-3AC14
	12.5 x 80 x 84	2 A	AC 24 – 250 V	0.05 A	100 A/20 ms	–	3TX700□-3AC03
AC 110–230 V	6.2 x 80 x 84	3 A	≤ DC 30 V	–	Short-circuit-pr.	–	3TX700□-3PG74
Input couplers with semiconductor output, 1 NO contact (6.2 mm width)							
AC/DC 110–230 V	6.2 x 80 x 84	0.1 A	≤ DC 30 V	–	0.2 A/3 ms	–	3TX700□-4PG24

1) With 3TX7004 (screw terminals), the height amounts to 79 mm

Screw terminals 
Spring-type terminals 

3TX7002 coupling relays with semiconductor output, not pluggable							
Output couplers with semiconductor output – for low line heights, 1 NO contact, screw terminals (6.2 mm width)							
Rated control supply voltage U_c	W x H x D in mm ¹⁾	Switching current max.	Switching voltage	Min. load current	Short-time load carrying capacity	Order No.	
DC 24 V	11.5 x 60 x 62	1.8 A	AC 48 – 264 V	0.06 A	20 A/20 ms	3TX7002-3AB00	
DC 24 V	11.5 x 60 x 62	1.5 A	≤ DC 60 V	–	4 A/200 ms	3TX7002-3AB01	
Input couplers with semiconductor output, 1 NO contact (6.2 mm width)							
AC/DC 24 V	11.5 x 60 x 62	0.1 A	≤ DC 30 V	–	1 A/20 ms	3TX7002-4AB00	
AC 110 – 240 V	12.5 x 60 x 62	0.1 A	≤ DC 30 V	–	1 A/20 ms	3TX7002-4AG00	
Accessories							
Connection cable with 24 clamping points for 3TX70						3TX7004-8BA00	
Connection comb with 24 clamping points for 3TX7004 with 6.2 mm width and screw terminals						3TX7004-8AA00	

3RS18 coupling relays		
Rated control supply voltage U_c , 50/60Hz	Contact version	Order No.
Wide voltage AC/DC 24 – 240 V	2 CO	3RS18 00-□BW00
	3 CO	3RS18 00-□HW00
	3 CO hard gold-plated	3RS18 00-□HW01
Combined voltage AC/DC 24 V and AC 110 – 120 V	1 CO	3RS18 00-□AQ00
	2 CO	3RS18 00-□BQ00
	3 CO	3RS18 00-□HQ00
	3 CO hard gold-plated	3RS18 00-□HQ01
AC/DC 24 V and AC 220 – 240 V	1 CO	3RS18 00-□AP00
	2 CO	3RS18 00-□BP00
	3 CO	3RS18 00-□HP00
	3 CO hard gold-plated	3RS18 00-□HP01

Screw terminals 
Spring-type terminals 

SIRIUS LZS Coupling Relays

LZS coupling relays with plug-in relays – for low line heights		
Output couplers		
Switching capacity of LZS plug-in relays	AC-15, 230 V	DC-13, 24 V
RT 1 CO	6 A	2 A
RT 2 CO	2.5 A	2 A
PT 2 CO	5 A	5 A
PT 3 CO	5 A	5 A
PT 4 CO	DC coil: 4 A, AC coil: 2 A	4 A
MT 3 CO	5 A	2 A

Logical isolation:
The connections of the contact elements and the connections of the coil are arranged on different sides, e.g. for contact elements at the top, and for the coil at the bottom. This improves the transparency of wiring. The logical isolation is not necessarily a safe isolation.

Safe isolation:
Safe isolation is a separation that prevents overspill of voltage from one circuit to another with adequate safety. (DIN VDE 106 Part 101)

Coupling relays with plug-in relays – LZS complete modules (base, plug-in relay, hold/eject clip, LED module and inscription plate)			
Versions	Rated control supply voltage U_c	Contacts	Order No. ¹⁾
Complete devices, 8-, 11- and 14-pole, PT range (28 mm width)			
Complete device with plug-in base (screw terminals, standard) for snap-on mounting on 35 mm DIN rail, consisting of: plug-in relay, standard plug-in base with screw terminals, LED module (24 V DC LED module with free-wheeling diode, AC without free-wheeling diode), hold/eject clip and inscription plate	DC 24 V	3 CO	LZS:PT3A5L24
	AC 24 V		LZS:PT3A5R24
	AC 115 V		LZS:PT3A5S15
	AC 230 V	4 CO	LZS:PT3A5T30
	DC 24 V		LZS:PT5A5L24
	AC 24 V		LZS:PT5A5R24
AC 115 V	LZS:PT5A5S15		
	AC 230 V	LZS:PT5A5T30	
	Complete device with plug-in base (screw terminals, logical isolation) for snap-on mounting on 35 mm DIN rail, consisting of: plug-in relay, plug-in base with screw terminals and logical isolation, LED module (24 V DC LED module with free-wheeling diode, AC without free-wheeling diode), hold/eject clip and inscription plate	DC 24 V	4 CO
AC 24 V		LZS:PT5B5R24	
AC 115 V		LZS:PT5B5S15	
AC 230 V		LZS:PT5B5T30	
Complete device with plug-in base (push-in spring-type terminals, logical isolation) for snap-on mounting on 35 mm DIN rail, consisting of: plug-in relay, plug-in base with spring-type terminals and logical isolation, LED module (24 V DC LED module with free-wheeling diode, AC without free-wheeling diode), hold/eject clip and inscription plate	DC 24 V	2 CO	LZS:PT2D5L24
	AC 230 V	LZS:PT2D5T30	
for snap-on mounting on 35 mm DIN rail, consisting of: plug-in relay, plug-in base with spring-type terminals and logical isolation, LED module (24 V DC LED module with free-wheeling diode, AC without free-wheeling diode), hold/eject clip and inscription plate	DC 24 V	4 CO	LZS:PT5D5L24
	AC 24 V		LZS:PT5D5R24
	AC 115 V		LZS:PT5D5S15
	AC 230 V		LZS:PT5D5T30
	AC 230 V		LZS:PT5D5T30
Complete devices, 8-pole, 5 mm pinning, RT range (15.5 mm width)			
Complete device with plug-in base (screw terminals, standard) for snap-on mounting on 35 mm DIN rail, consisting of: plug-in relay, standard plug-in base with screw terminals, LED module (24 V DC LED module with free-wheeling diode, AC without free-wheeling diode), hold/eject clip and inscription plate	DC 24 V	1 CO	LZS:RT3A4L24
	DC 24 V	2 CO	LZS:RT4A4L24
	AC 230 V	1 CO	LZS:RT3A4T30
	AC 230 V	2 CO	LZS:RT4A4T30
	AC 24 V	1 CO	LZS:RT3A4R24
	AC 24 V	2 CO	LZS:RT4A4R24
	AC 115 V	1 CO	LZS:RT3A4S15
	AC 115 V	2 CO	LZS:RT4A4S15
Complete device with plug-in base (screw terminals, logical isolation) for snap-on mounting on 35 mm DIN rail, consisting of: plug-in relay with safe isolation, plug-in base with screw terminals and logical isolation, LED module (24 V DC module with free-wheeling diode, AC without free-wheeling diode), hold/eject clip and inscription plate	DC 24 V	1 CO	LZS:RT3B4L24
	DC 24 V	2 CO	LZS:RT4B4L24
	AC 230 V	1 CO	LZS:RT3B4T30
	AC 230 V	2 CO	LZS:RT4B4T30
	AC 24 V	1 CO	LZS:RT3B4R24
	AC 24 V	2 CO	LZS:RT4B4R24
	AC 115 V	1 CO	LZS:RT3B4S15
	AC 115 V	2 CO	LZS:RT4B4S15
Complete device with plug-in base (Push-in spring-type terminals, logical isolation) for snap-on mounting on 35 mm DIN rail, consisting of: plug-in relay, plug-in base with spring-type terminals and logical isolation, LED module (24 V DC LED module with free-wheeling diode, AC without free-wheeling diode), hold/eject clip and inscription plate	DC 24 V	1 CO	LZS:RT3D4L24
	DC 24 V	2 CO	LZS:RT4D4L24
	AC 230 V	1 CO	LZS:RT3D4T30
	AC 230 V	2 CO	LZS:RT4D4T30
	AC 24 V	1 CO	LZS:RT3D4R24
	AC 24 V	2 CO	LZS:RT4D4R24
	AC 115 V	1 CO	LZS:RT3D4S15
	AC 115 V	2 CO	LZS:RT4D4S15

Coupling relays with plug-in relays – individual modules for self-assembly (LZX)

RT range						
Plug-in relays						
Rated control supply voltage U_c	Contacts	LED	Free-wheeling diode	Logical isolation	Hard gold plating	Order No.
DC 12V	2 CO	–	–	–	–	LZX:RT424012
DC 24 V	1 CO	–	–	–	–	LZX:RT314024
DC 24 V	2 CO	–	–	–	–	LZX:RT424024
AC 24 V	1 CO	–	–	–	–	LZX:RT424524
AC 24 V	2 CO	–	–	–	–	LZX:RT424524
AC 115 V	1 CO	–	–	–	–	LZX:RT314615
AC 115 V	2 CO	–	–	–	–	LZX:RT424615
AC 230 V	1 CO	–	–	–	–	LZX:RT314730
AC 230 V	2 CO	–	–	–	–	LZX:RT424730
DC 24 V	1 CO	–	–	–	Yes	LZX:RT315024
AC 230 V	1 CO	–	–	–	Yes	LZX:RT315730

RT range		
Accessories, suitable for 1 and 2 CO		
Plug-in base with screw terminals for DIN rail mounting	No logical isolation (standard)	LZS:RT78725
	Logical isolation	LZS:RT78726
Plug-in base with push-in spring-type terminals for DIN rail mounting	Logical isolation	LZS:RT7872P
Hold/eject clip	–	LZS:RT17016
Inscription plate		LZS:RT17040
Wiring bracket for push-in spring-type terminal base	2-pole	LZS:RT170P1
Wiring comb for screw terminal base	8-pole	LZS:RT170R8

PT range						
Plug-in relays						
Rated control supply voltage U_c	Contacts	LED	Free-wheeling diode	Hard gold plating	Test bracket	Order No.
DC 24 V	2 CO	–	–	–	Yes	LZX:PT270024
DC 24 V	3 CO	–	–	–	Yes	LZX:PT370024
DC 24 V	4 CO	–	–	–	Yes	LZX:PT570024
DC 24 V	4 CO	–	–	–	–	LZX:PT520024
DC 24 V	4 CO	–	–	Yes	Yes	LZX:PT580024
AC 24 V	2 CO	–	–	–	Yes	LZX:PT270524
AC 24 V	3 CO	–	–	–	Yes	LZX:PT370524
AC 24 V	4 CO	–	–	–	Yes	LZX:PT570524
AC 115 V	2 CO	–	–	–	Yes	LZX:PT270615
AC 115 V	3 CO	–	–	–	Yes	LZX:PT370615
AC 115 V	4 CO	–	–	–	Yes	LZX:PT570615
AC 230 V	2 CO	–	–	–	Yes	LZX:PT270730
AC 230 V	3 CO	–	–	–	Yes	LZX:PT370730
AC 230 V	4 CO	–	–	–	Yes	LZX:PT570730
AC 230 V	4 CO	–	–	Yes	Yes	LZX:PT580730
AC 230 V	4 CO	–	–	–	–	LZX:PT520730

Accessories				
Plug-in base with screw terminals for DIN rail mounting	2 CO	No logical isolation	LZS:PT78720	
	3 CO		LZS:PT78730	
	4 CO		LZS:PT78740	
	2 CO		Logical isolation	LZS:PT78722
	4 CO			LZS:PT78742
Plug-in base with push-in spring-type terminals for DIN rail mounting	2 CO	Logical isolation	LZS:PT7872P	
	4 CO		LZS:PT7874P	
Hold/eject clip	2/3/4 CO	Logical isolation	LZS:PT17021	
Hold/eject clip for screw terminal base	2/3/4 CO	No logical isolation	LZS:PT17024	
Inscription plate			LZS:PT17040	
Wiring bracket for push-in spring-type terminal base		2-pole	LZS:PT170P1	
Wiring comb for screw terminal base		6-pole	LZS:PT170R6	

Accessories for RT and PT range				
LED module red	Control supply voltage	DC 24 V	Free-wheeling diode	LZS:PTML0024
		AC/DC 24 V	–	LZS:PTML0524
		AC 110–230 V	–	LZS:PTML0730
LED module green		DC 24 V	Free-wheeling diode	LZS:PTMG0024
		AC/DC 24 V	–	LZS:PTMG0524
		AC 110–230 V	–	LZS:PTMG0730
Free-wheeling diode		DC 6–230 V	Free-wheeling diode	LZS:PTMT00A0
RC link		AC 24–48 V	–	LZS:PTMU0524
		AC 110–230 V	–	LZS:PTMU0730

MT range					
Plug-in relays					
Rated control supply voltage U_c	Contacts	LED	Free-wheeling diode	Order No.	
DC 24 V	3 CO	–	–	LZX:MT321024	
DC 24 V	3 CO	Yes	–	LZX:MT323024	
AC 24 V	3 CO	–	–	LZX:MT326024	
AC 24 V	3 CO	Yes	–	LZX:MT328024	
AC 115 V	3 CO	–	–	LZX:MT326115	
AC 115 V	3 CO	Yes	–	LZX:MT328115	
AC 230 V	3 CO	–	–	LZX:MT326230	
AC 230 V	3 CO	Yes	–	LZX:MT328230	
Accessories					
Plug-in base with screw terminals for DIN rail mounting, 11-pole				LZS:MT78750	
Hold clip				LZS:MT28800	

SIRIUS 3RS17 Interface Converters

Single interface converters, active, 2-way isolation						
Input	Output	Width	Manual-automatic	Rated control supply voltage U_c	Galvanic isolation	Order No.
0–10 V	0–10 V	6.2 mm	–	AC/DC 24 V	2-way	3RS1700-□AD00
0–10 V	0–20 mA	6.2 mm	–	AC/DC 24 V	2-way	3RS1700-□CD00
0–10 V	4–20 mA	6.2 mm	–	AC/DC 24 V	2-way	3RS1700-□DD00
0–20 mA	0–10 V	6.2 mm	–	AC/DC 24 V	2-way	3RS1702-□AD00
0–20 mA	0–20 mA	6.2 mm	–	AC/DC 24 V	2-way	3RS1702-□CD00
0–20 mA	4–20 mA	6.2 mm	–	AC/DC 24 V	2-way	3RS1702-□DD00
4–20 mA	0–10 V	6.2 mm	–	AC/DC 24 V	2-way	3RS1703-□AD00
4–20 mA	0–20 mA	6.2 mm	–	AC/DC 24 V	2-way	3RS1703-□CD00
4–20 mA	4–20 mA	6.2 mm	–	AC/DC 24 V	2-way	3RS1703-□DD00
0–20 mA	0–20 mA	6.2 mm	–	Passive converter	2-way	3RS1720-□ET00
0–20 mA	0–20 mA	12.5 mm	–	Passive converter	2-way	3RS1721-□ET00
2 x 0–20 mA	2 x 0–20 mA	12.5 mm	–	Passive converter	2-way	3RS1722-□ET00

Single interface converters, active, 3-way isolation						
0–10 V	0–10 V	6.2 mm	–	AC/DC 24 V	3-way	3RS1700-□AE00
0–10 V	0–20 mA	6.2 mm	–	AC/DC 24 V	3-way	3RS1700-□CE00
0–10 V	4–20 mA	6.2 mm	–	AC/DC 24 V	3-way	3RS1700-□DE00
0–20 mA	0–10 V	6.2 mm	–	AC/DC 24 V	3-way	3RS1702-□AE00
0–20 mA	0–20 mA	6.2 mm	–	AC/DC 24 V	3-way	3RS1702-□CE00
0–20 mA	4–20 mA	6.2 mm	–	AC/DC 24 V	3-way	3RS1702-□DE00
4–20 mA	0–10 V	6.2 mm	–	AC/DC 24 V	3-way	3RS1703-□AE00
4–20 mA	0–20 mA	6.2 mm	–	AC/DC 24 V	3-way	3RS1703-□CE00
4–20 mA	4–20 mA	6.2 mm	–	AC/DC 24 V	3-way	3RS1703-□DE00

Multi-range converters, switchable, active						
0–10 V 0/4–20 mA adjustable	0–10 V 0/4–20 mA adjustable	6.2 mm	–	AC/DC 24 V	2-way	3RS1705-□FD00
		6.2 mm	–	AC/DC 24 V	3-way	3RS1705-□FE00
		17.5 mm	–	AC/DC 24–240 V	3-way	3RS1705-□FW00
0–10 V 0/4–20 mA adjustable	0–10 V 0/4–20 mA adjustable	17.5 mm	Yes	AC/DC 24 V	2-way	3RS1725-□FD00
		17.5 mm	Yes	AC/DC 24–240 V	3-way	3RS1725-□FW00
0–10 V 0/4–20 mA adjustable	0–50 Hz 0–100 Hz 0–1 kHz 0–10 kHz adjustable	6.2 mm	–	AC/DC 24 V	2-way	3RS1705-□KD00
		17.5 mm	–	AC/DC 24–240 V	3-way	3RS1705-□KW00

Universal converters, active, with 16 input and output ranges									
0–60 mV	0–10 V 0/4–20 mA adjustable	17.5 mm	–						
0–100 mV									
0–300 mV									
0–500 mV									
0–1 V									
0–2 V									
0–5 V									
0–10 V							AC/DC 24 V	2-way	3RS1706-□FD00
0–20 V							AC/DC 24 V	3-way	3RS1706-□FE00
2–10 V							AC/DC 24–240 V	3-way	3RS1706-□FW00
0–5 mA									
0–10 mA									
0–20 mA									
4–20 mA									
± 5 mA									
± 20 mA									

Screw terminals **1**
Spring-type terminals **2**

SIRIUS 3TG10 Power Relays

3TG10 power relays							
AC-1 operating current I_n with 400 V	AC-1 power of three-phase loads with 50 Hz 400 V	AC-2 and AC-3 operating current with 400 V	AC-2 and AC-3 three-phase loads with 50 Hz 400 V	Contacts	Connection system	Rated control supply voltage U_c	Order No.
(A)	(kW)	(A)	(kW)				
20	13	8.4	4	3 NO + 1 NC	Screw terminals	AC 24 V	3TG1001-0AC2
						AC 110 V	3TG1001-0AG2
						AC 230 V	3TG1001-0AL2
						DC 24 V	3TG1001-0BB4
20	13	8.4	4	4 NO	Screw terminals	AC 24 V	3TG1010-0AC2
						AC 110 V	3TG1010-0AG2
						AC 230 V	3TG1010-0AL2
						DC 24 V	3TG1010-0BB4
16	10	8.4	4	3 NO + 1 NC	Flat connectors	AC 24 V	3TG1001-1AC2
						AC 110 V	3TG1001-1AG2
						AC 230 V	3TG1001-1AL2
						DC 24 V	3TG1001-1BB4
16	10	8.4	4	4 NO	Flat connectors	AC 24 V	3TG1010-1AC2
						AC 110 V	3TG1010-1AG2
						AC 230 V	3TG1010-1AL2
						DC 24 V	3TG1010-1BB4

Scan the
QR code
for further
information

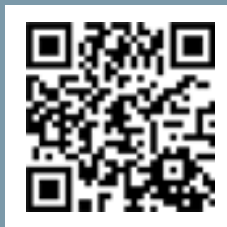

Further information:
siemens.com/relays

Siemens AG
Industry Sector
Control Components
and System Engineering
P.O. Box 4848
90026 NUREMBERG
GERMANY

Subject to change 03/13
Oder No. E20001-A1800-P302-V1-7600
Dispo 27601
21/42527 MI.CE.SG.REXX.52.2.01 WS 03131.
Printed in Germany
© Siemens AG 2013

The information provided in this brochure contains merely general descriptions or characteristics of performance which in actual case of use do not always apply as described or which may change as a result of further development of the products. An obligation to provide the respective characteristics shall only exist if expressly agreed in the terms of contract.

All product designations may be trademarks and product names of Siemens AG or supplier companies whose use by third parties for their own purposes could violate the rights of the owners.